

1-1/8" STAINLESS STEEL GRIDLINE 2 (RADIUSED RAILS) WITH RECESSED LEVEL BASE FRAME AND BAFFLE

INSERT STYLE: N/A INSERT COLOR: N/A CATALOG NUMBER: G6 PART NUMBER:

NO.	REVISION	DATE	BY
NO.	F&F RELEASE	DATE	BY

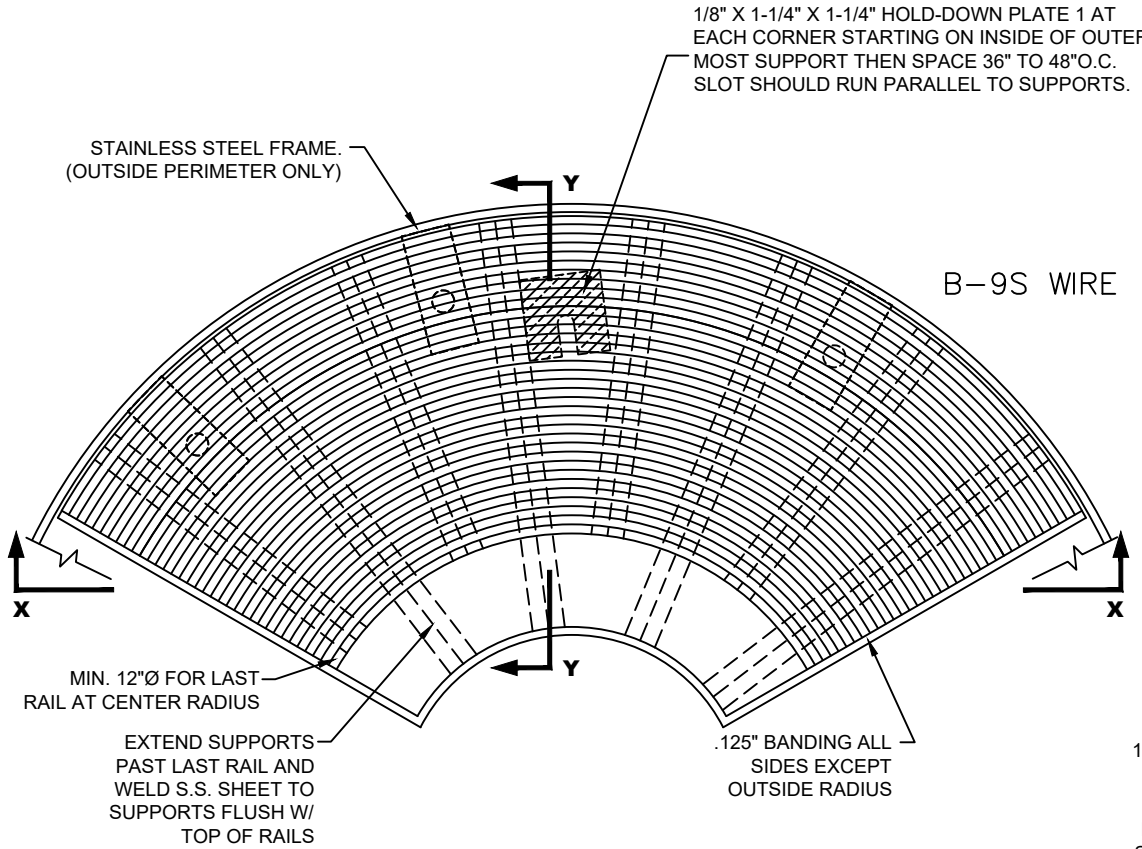

TYPICAL MODULE PLAN VIEW
NOT TO SCALE

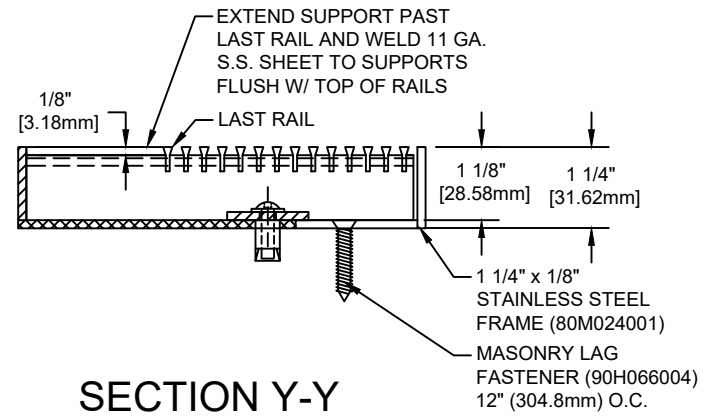

SECTION Y-Y
NOT TO SCALE

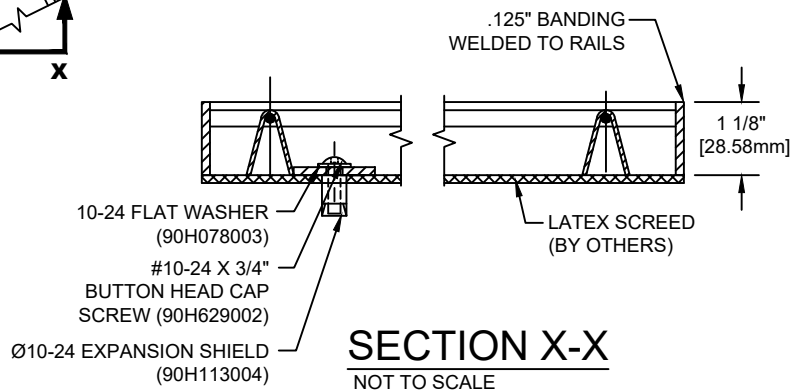

SECTION X-X
NOT TO SCALE

*GRIDS SHALL BE ABLE TO SUPPORT A 500LB ROLLING LOAD.
* SURFACE WIRE SPACING PROVIDES A 57.7% EFFECTIVE OPEN AREA FOR DIRT AND MOISTURE REMOVAL.

NOTES:

- *MECHANICALLY INTERLOCKED DESIGN TO ENSURE CORRECT WEIGHT BEARING PROPERTIES.
- *GRIDS SHALL BE ABLE TO SUPPORT A 500LB ROLLING LOAD.
- * SURFACE WIRE SPACING PROVIDES A 57.7% EFFECTIVE OPEN AREA FOR DIRT AND MOISTURE REMOVAL.

CS Construction Specialties™
6696 Route 405 Highway, Muncy PA 17756
(800) 233-8493 • Fax (570) 546-4692 • www.c-sgroup.com

PLEASE VERIFY ALL	QTY	MARK #	LOCATION	MODEL	DIM 'A' WIDTH	DIM 'B' LENGTH	REMARKS

PROJECT:		
LOCATION:		
CONTRACTOR:		
AGENT:		SHT:
DRG. BY:	DATE:	JOB NO.: