

FSC-25N CHANNEL GUARD

PLEASE READ

PLEASE READ THESE INSTRUCTIONS THOROUGHLY PRIOR TO BEGINNING THE FSC-25N CHANNEL GUARD INSTALLATION!

THIS INSTRUCTION SHEET IS INTENDED TO PROVIDE A SPECIFIC GUIDE TO FOLLOW FOR THE INSTALLATION OF FSC-25N CHANNEL GUARD. CONTAINED WITHIN IS THE THE TECHNICAL INFORMATION AND INSTALLATION TECHNIQUES REQUIRED TO COMPLETE AN EFFICIENT, NEAT AND LONG-LASTING INSTALLATION.

INSPECT ALL MATERIALS FOR DAMAGE OR MISSING PARTS. IF YOU DISCOVER DAMAGED OR MISSING MATERIALS, IN THE USA PLEASE NOTIFY THE FACTORY AT (800) 233-8493, AND IN CANADA (888) 895-8955.

FSC-25N CHANNEL GUARD MUST BE INSTALLED IN ACCORDANCE WITH THESE INSTRUCTIONS! FAILURE TO FOLLOW THESE INSTRUCTIONS MAY VOID ANY PRODUCT WARRANTIES AND RESULT IN AN UNSUCCESSFUL INSTALLATION. FOR SPECIFIC QUESTIONS REGARDING THE INSTALLATION OF FSC-25N CHANNEL GUARD PLEASE CALL THE FACTORY IN THE USA AT (800) 233-8493 OR EMAIL IWPTECHSUPPORT@C-SGROUP.COM. IN CANADA CALL (888) 895-8955.

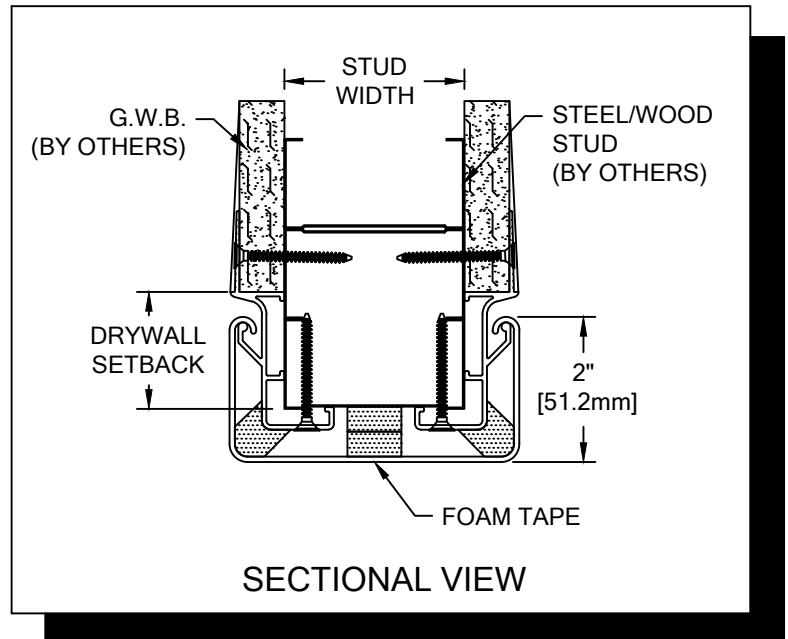

IMPORTANT NOTES

1. ALL MATERIAL TO BE SUPPLIED IN STOCK LENGTHS. ALUMINUM RETAINER IN LENGTHS UP TO 20'-0" AND ACROVYN COVERS IN LENGTHS UP TO 10'-0". THIS MATERIAL IS TO BE FIELD CUT USING QUALITY EQUIPMENT TO INSURE THAT ALL CUTS ARE SQUARE. WHEN CUTTING MATERIAL SECTIONS, CS RECOMMENDS USING AN 80-100 TOOTH CARBIDE TIPPED SAW BLADE OR EQUIVALENT, TO MINIMIZE CHIPPING AND MAINTAIN JOINT ALIGNMENT.
2. ALL DIMENSIONS ARE TYPICAL.
3. FOR DRYWALL/PLASTER WALL CONSTRUCTION, IT IS RECOMMENDED FOR FASTENERS TO BE ENGAGED INTO METAL/WOOD STUDS TO MAINTAIN MAXIMUM PULLOUT STRENGTH. IF DURING INSTALLATION YOU ENCOUNTER SPECIAL WALL CONDITIONS THAT DO NOT ALLOW FOR ATTACHMENT FOR DIRECT ATTACHMENT TO THE STUDS PLEASE CONSULT THE LOCAL AUTHORITY HAVING JURISDICTION.
4. MATERIAL MUST REACH 65°F MIN. TO 75°F MAX. 24 HOURS PRIOR TO INSTALLATION. THIS IS ESSENTIAL TO MINIMIZE EXPANSION AND CONTRACTION OF MATERIAL.
5. FOR MORE INFORMATION ON FLUSH MOUNTED CORNER GUARDS SEE OUR WEBSITE AT www.c-sgroup.com.

FSC-25N CHANNEL GUARD

SECTIONAL VIEWS

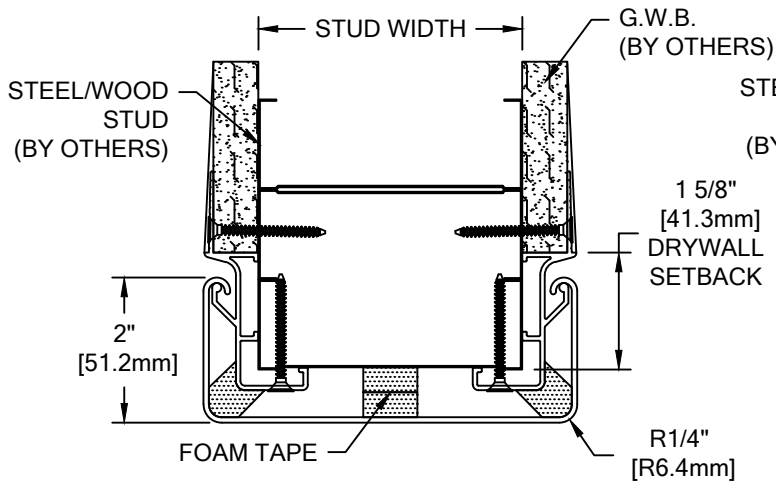

FSC-25N (5/8" DRYWALL)

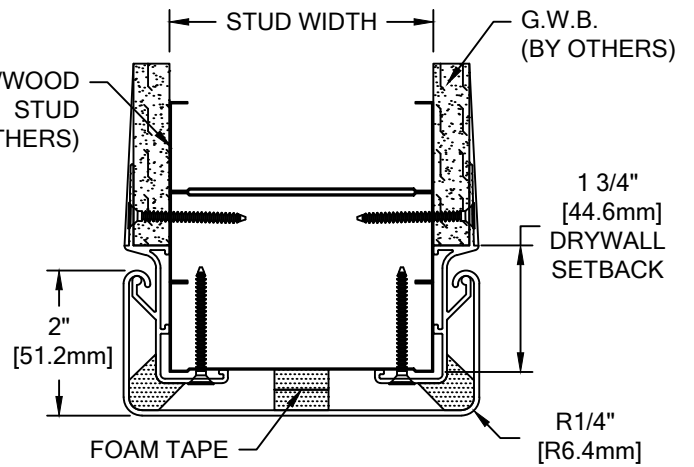

FSC-25N (1/2" DRYWALL)

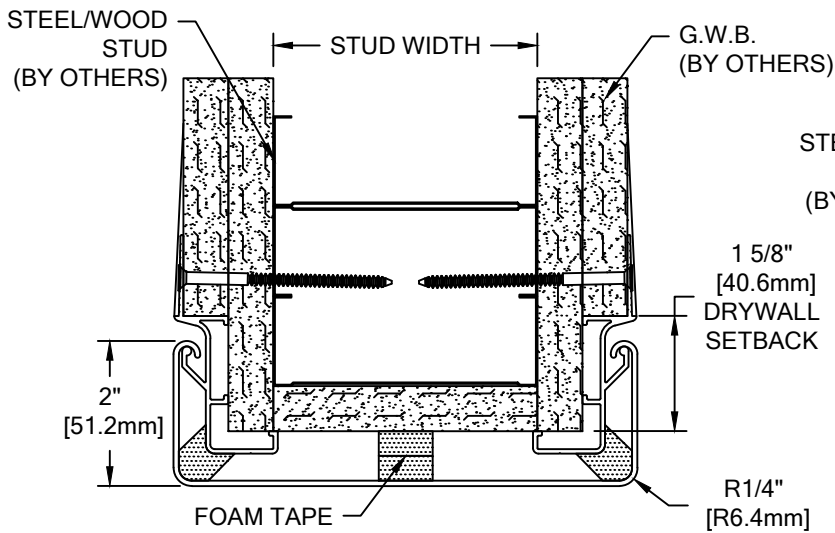

FSC-25N (2 LAYERS OF 5/8" DRYWALL)

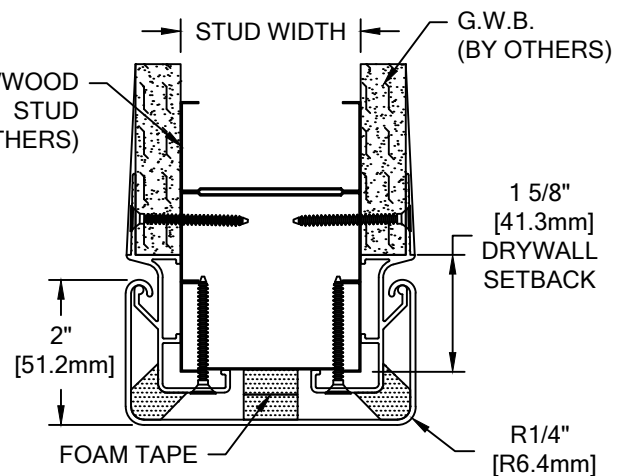

FSC-25N (2 1/2" STUD WALL and 5/8" DRYWALL)

FSC-25N CHANNEL GUARD

COMPONENTS & WALL FASTENERS



FSC-25N ACRYVYN COVER

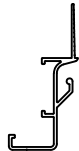

FSC-25N
ALUMINUM RETAINER
(24A285000 - 1/2" DRYWALL)
(24A284000 - 5/8" DRYWALL)



GASKET
(24M013xxx)

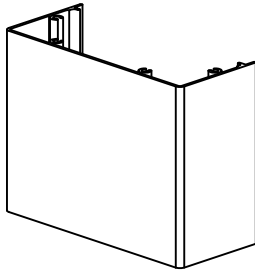

ALUMINUM BASE
(24F013000 - 4")
(24F148000 - 6")

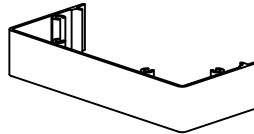

1" ALUMINUM
CLOSURE CAP
(24F095000)



3/4" FOAM TAPE
(90M008002C)

WALL CONDITION	SPECIFIED FASTENER	DRILL DIAMETERS		CS PART NUMBER
		WALL	RETAINER	
SINGLE LAYER DRYWALL	#6 X 1-5/8" BUGLE HEAD SHEET METAL SCREW	N/A	N/A	90H079002
DOUBLE LAYER DRYWALL	#8 X 3" BUGLE HEAD SHEET METAL SCREW	N/A	N/A	90H857002

FSC-25N CHANNEL GUARD

STANDARD DEDUCTIONS

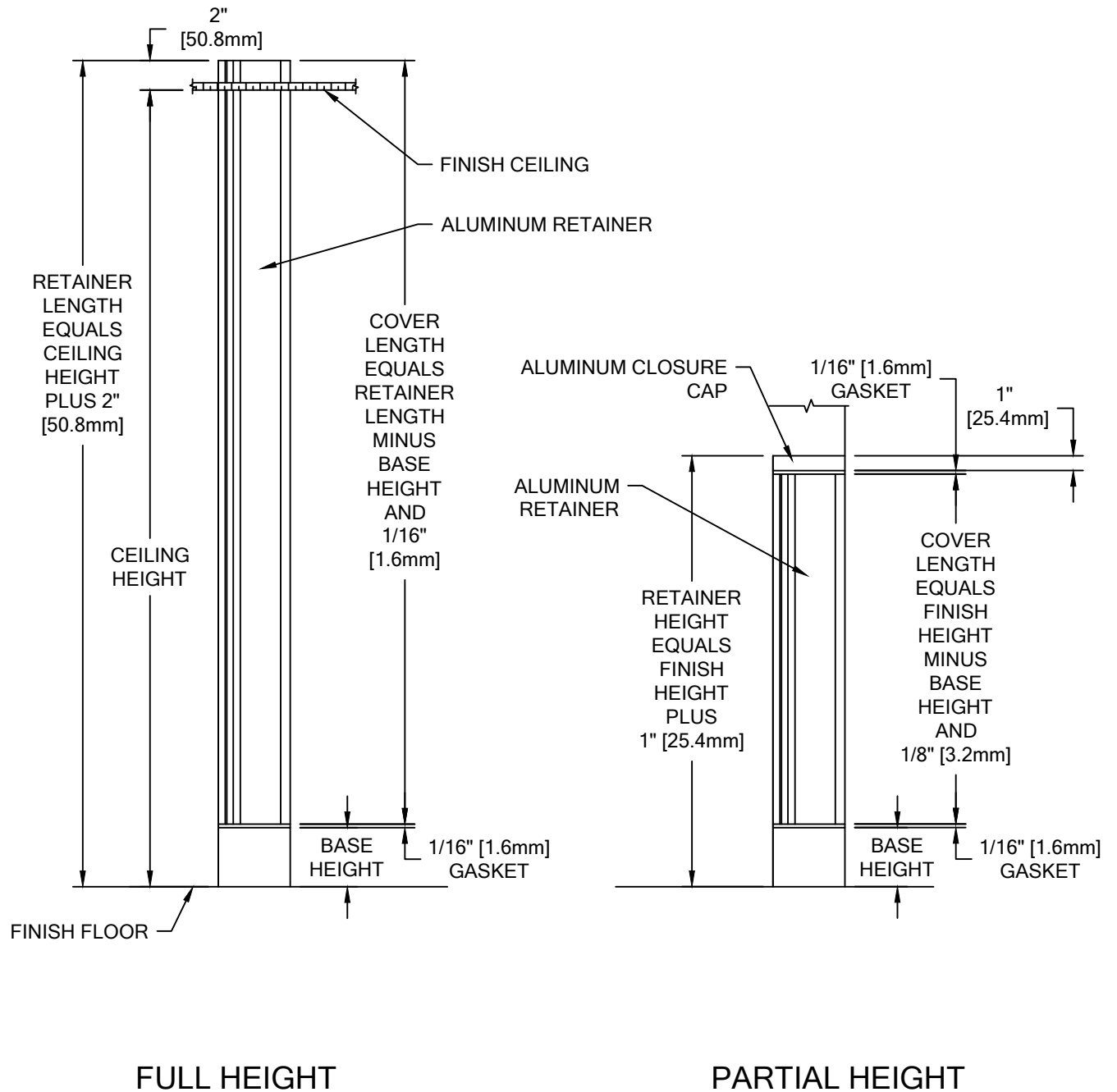

FSC-25N CHANNEL GUARD

TYPICAL ASSEMBLY

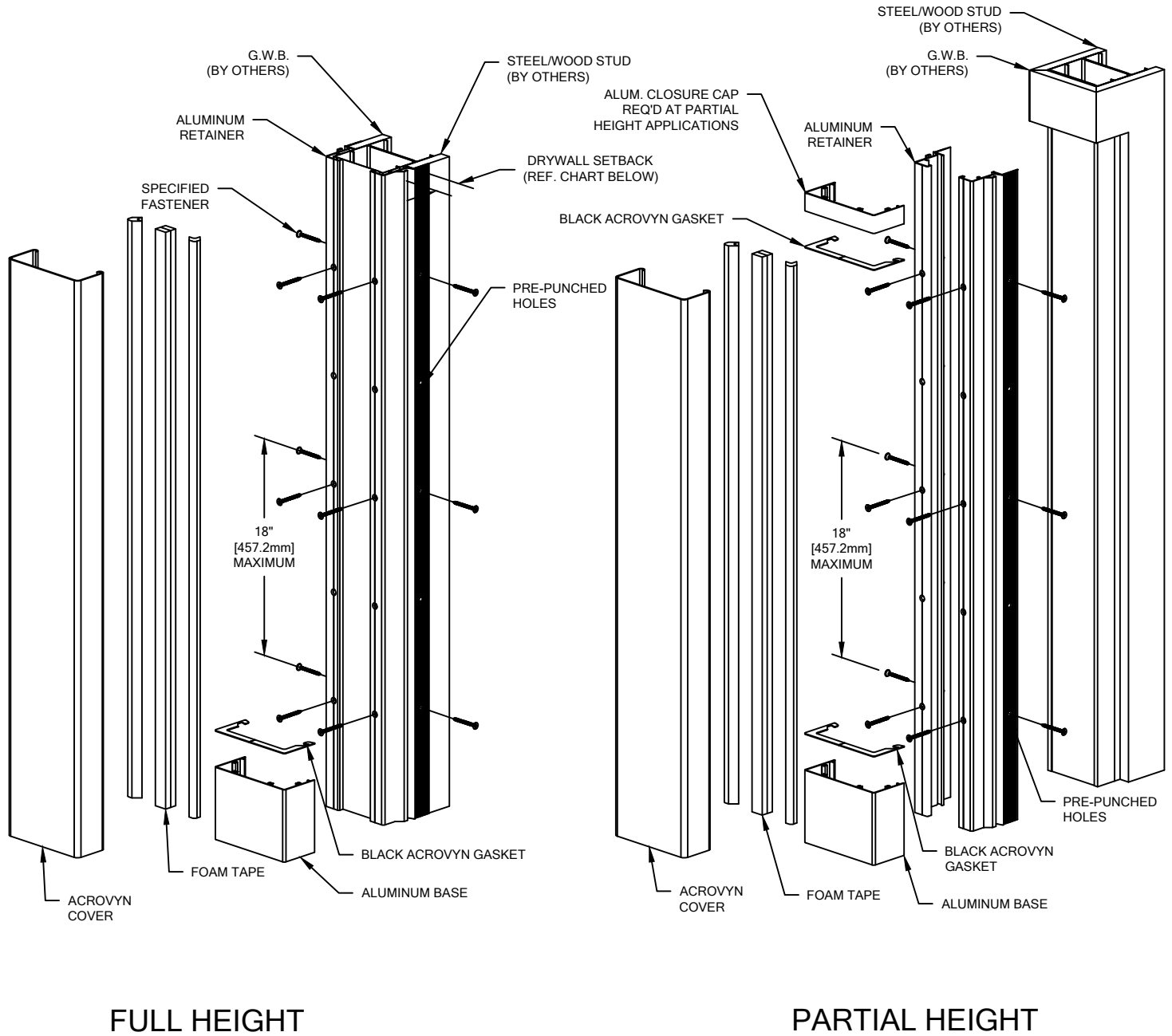

FULL HEIGHT

PARTIAL HEIGHT

DRYWALL SETBACK CHART			
1/2" THK.	5/8" THK.	5/8" (2) THK.	5/8" THK. (2 1/2" STUD)
1 3/4" [44.5mm]	1 5/8" [44.5mm]	1 5/8" [44.5mm]	1 5/8" [44.5mm]

FSC-25N CHANNEL GUARD

TYPICAL ASSEMBLY

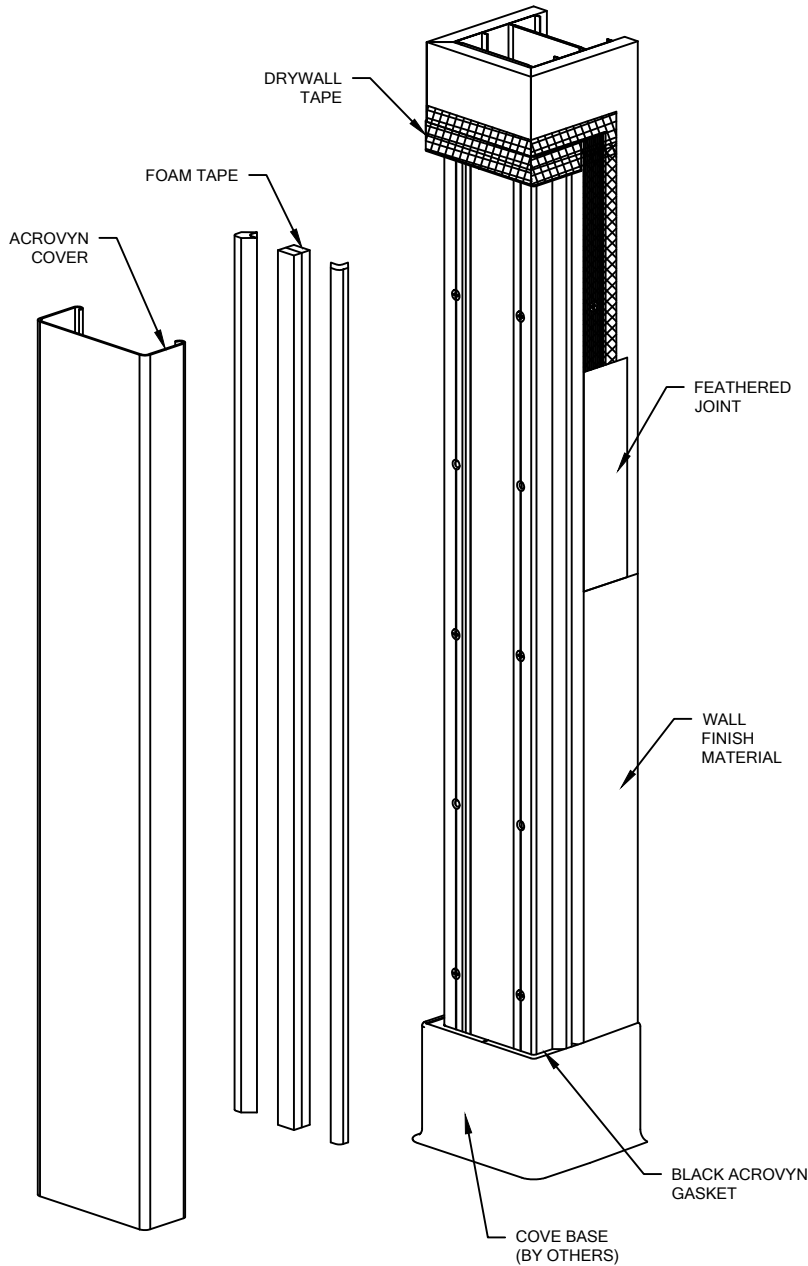

1. ALL FLUSH MOUNTED CORNER GUARDS ARE SHIPPED WITH CUT-TO-LENGTH ALUMINUM RETAINERS WITH FACTORY DRILLED HOLES IN THE RETAINER.
2. WHEN INSTALLING THE GYPSUM BOARD OR PLASTER, CONSULT THE CHART ON PAGE 5 TO DETERMINE THE SETBACK DISTANCE TO PROVIDE A SNUG FIT WHEN THE RETAINER IS INSTALLED.
3. ALIGN EACH RETAINER WITH THE CORNER AND SECURE EACH LEG THROUGH THE WALL INTO THE METAL/WOOD STUDS USING THE SPECIFIED FASTENERS. MAKE SURE THE RETAINER REMAINS PLUMB WITH THE FINISH FLOOR.

NOTE: FOR SINGLE LAYER DRYWALL UNITS WITH STUDS WIDER THAN 3 5/8" OR DOUBLE GWB APPLICATIONS, THE BASE, TOP CAP AND ASSOCIATE PARTS HAVE BEEN FACTORY SPLIT. THE SNAP-ON BASE AND TOP CAP HAVE BEEN WELDED TO ACCOMMODATE THE EXTRA WIDTH. THE ACROVYN GASKET IS SHIPPED IN PARTS, WITH EXTRA PIECES INCLUDED, SO THE INSTALLER CAN FABRICATE A WORKABLE GASKET.

4. INSERT ALUMINUM BASE CLOSURE AT THE BASE OF THE RETAINER AND SECURE THE ACROVYN GASKET ON TOP. ALIGN GASKET WITH OUTSIDE EDGE.
5. A 1" [25.4mm] CLOSURE CAP IS TO BE INSTALLED AT TOP OF RETAINER ON PARTIAL HEIGHT GUARDS. FOLLOWING PROCEDURES SIMILAR TO STEP 4.
6. APPLY 2" [50.8mm] JOINT TAPE ALONG THE EDGE OF THE DRYWALL AND THE ALUMINUM RETAINER. FINISH THE INSTALLATION BY APPLYING A UNIFORM FEATHERED JOINT AT THIS LOCATION AS PER STANDARD CONSTRUCTION PRACTICES. ALLOW TO DRY AND THEN SAND AS REQUIRED. APPLY ADDITIONAL COATS, AS REQUIRED, TO PROVIDE A UNIFORM AND NEAT FINISH. APPLY THE PROCEDURE TO ANY "CLOSURE CAPS" USED ON PARTIAL HEIGHT INSTALLATIONS.
7. FINISH WALL SURFACE AS SPECIFIED. BE SURE THAT THE SELECTED FINISH IS APPLIED TO THE INSIDE SURFACE OF THE REAR "CONTOURED" PORTION OF THE ALUMINUM RETAINER.
8. APPLY A SINGLE THICKNESS OF FOAM TAPE ONTO BOTH CORNERS AND A DOUBLE THICKNESS ALONG CENTER OF ALUMINUM RETAINER.

NOTE: IF THE RETAINER HAS BEEN SPLIT, APPLY THE CENTER TAPE ALONG ONE EDGE OF THE SPLIT.

9. FINISH INSTALLATION BY SNAPPING THE ACROVYN COVER ONTO THE RETAINER.

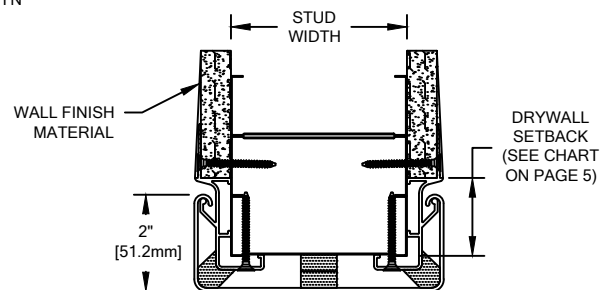

12/07/17