

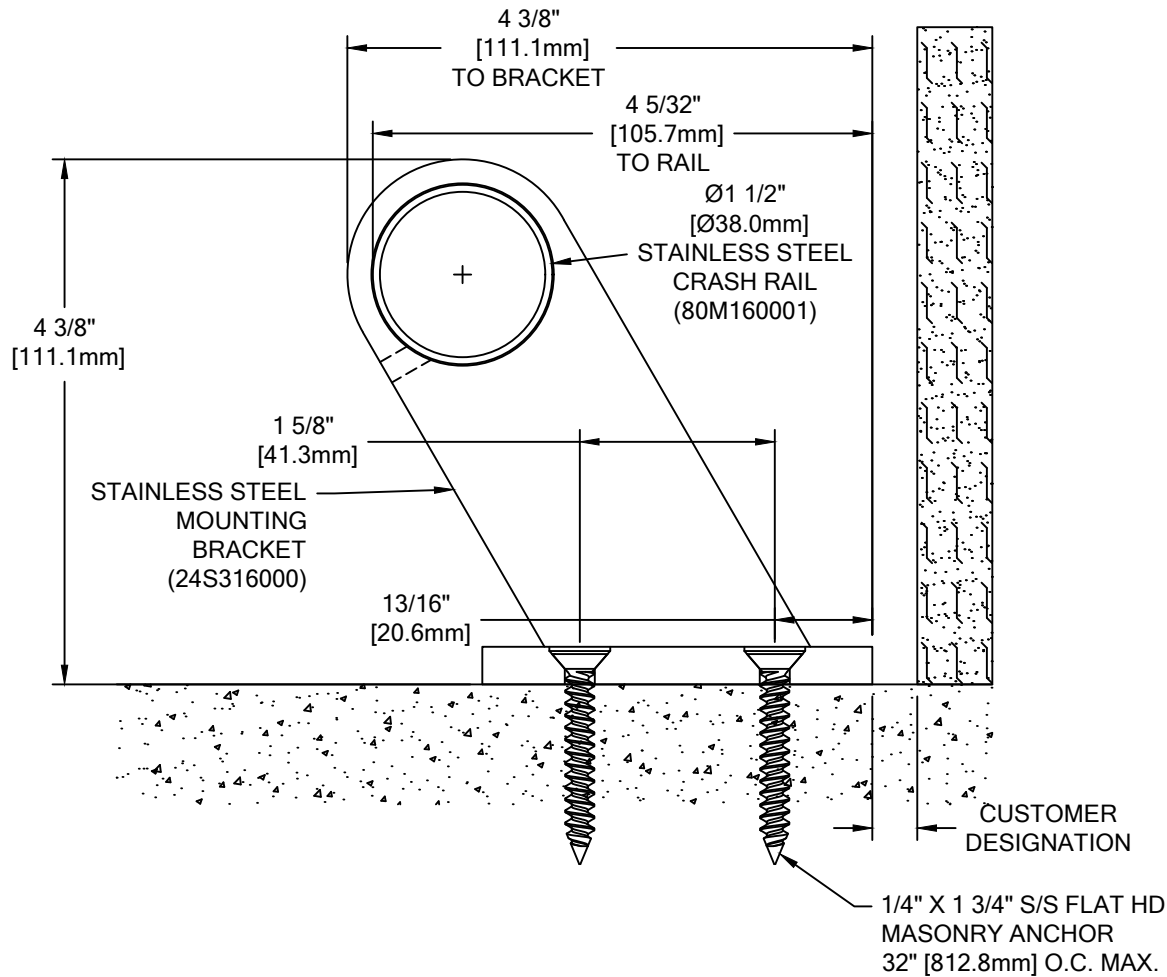

NOTE: STAINLESS STEEL CORNERS OTHER THAN 90° ARE UNAVAILABLE FOR THIS MODEL. THIS MODEL IS PRE-FABRICATED CUT-TO-SIZE, THEREFORE FIELD VERIFIED DIMENSIONS ARE REQUIRED. FIELD VERIFIED DIMENSIONS SHOULD BE COMPLETE LENGTH OF FLOOR THAT THE HANDRAIL WILL BE FASTENED TO.

TOTAL L/F REQ'D	END CAPS	I.S./O.S. REQ'D	OPTIONAL END PLUGS



## ECR-6SF

WALL CONDITION	SPECIFIED FASTENER	DRILL DIAMETERS		CS PART NUMBER
		WALL	RETAINER	
CONCRETE/CONC. BLOCK	1/4" X 1 3/4" S/S FLAT HEAD MASONRY ANCHOR	3/16"	N/A	90H390000

 <p>Hughesville, PA   800.233.8493   570.546.5941 Mississauga, ON   888.895.8955   905.274.3611 <a href="http://www.c-sgroup.com">www.c-sgroup.com</a></p> <p>© Copyright 2016 Construction Specialties, Inc.</p>	<b>PROJECT:</b>	<b>REVISION:</b>
	<b>JOB NO.:</b>	<b>F&amp;F:</b>
	<b>CUSTOMER:</b>	
	<b>REP:</b>	<b>DATE:</b>
	<b>DRAWN BY:</b>	<b>SHEET NO:</b>