

SINGLE DRAINABLE MULLION/SUPPORT LOUVER MODEL A4097

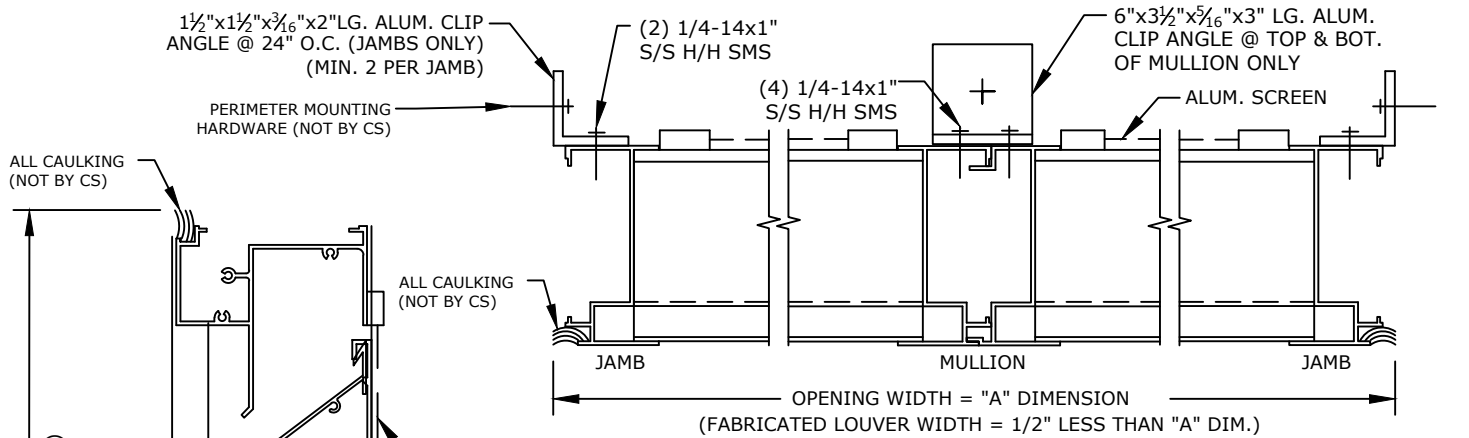

PLAN VIEW (NTS)

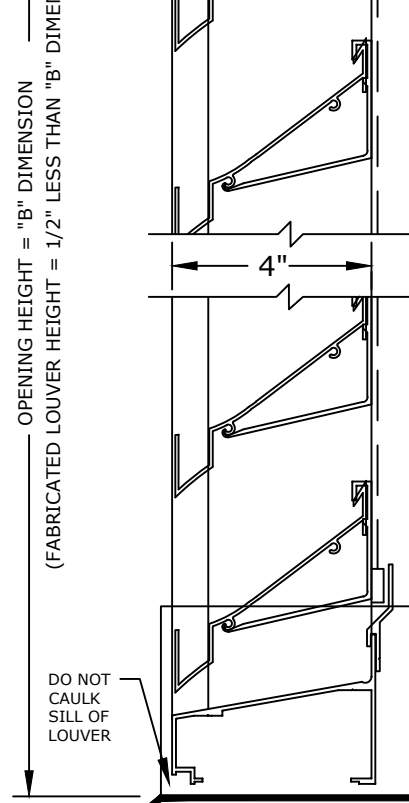

VERTICAL SECTION (NTS)

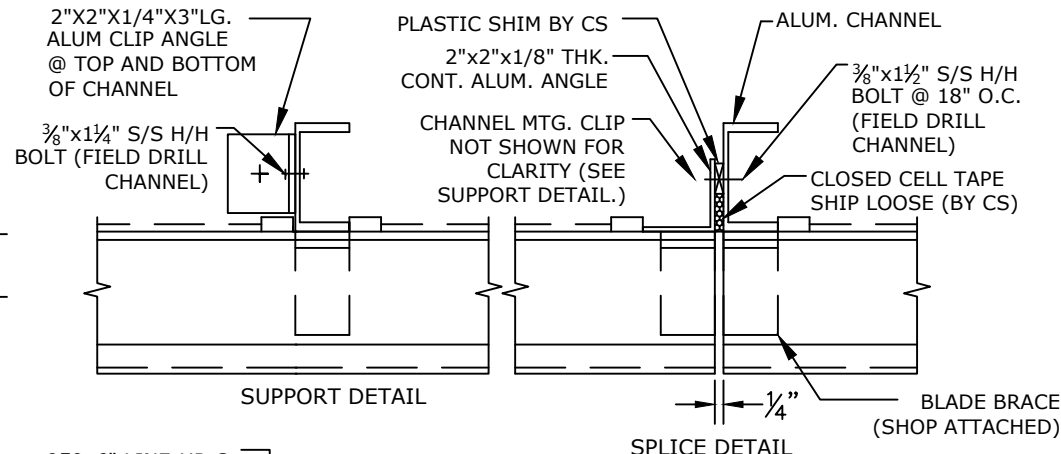

SCREENS

- SCREEN NOT REQUIRED
- SCREEN REQUIRED
- INTERIOR MOUNTED
- EXTERIOR MOUNTED
- BIRDSCREEN: 1/2" MESH .063 DIA. ALUM. WIRE (MILL FINISH)
- INSECT SCREEN (18x16 ALUM. MESH) (MILL FINISH)

FINISHES

- STANDARD MILL
- FLUOROPOLYMER POWDER COAT (NOT AVAILABLE IN 600XL OR 700)
- KYNAR (500),(600XL)or(700)
- (1) OF CS STD. COLORS
- CUSTOM COLOR, CS REQUIRES A COLOR CHIP FOR MATCHING
- BRONZE ANODIC (DARK OR MED.)
- CLEAR ANODIZE
- OTHER _____

CS EXTRUDED ALUMINUM SINGLE DRAINABLE LOUVER MODEL A4097. FRAMES AND BLADES TO BE FABRICATED FROM 6063-T6 ALLOY, WITH REINFORCING BOSSES. ALL FASTENERS TO BE STAINLESS STEEL.

UNSUPPORTED BLADE LENGTH= @ PSF.

MARK	QTY.	"A" DIM.	"B" DIM.	# OF MULLIONS	# OF SPLICES	# OF SUPPORTS	LOUVER LOCATION	REMARKS

Construction Specialties, Inc.
3 Werner Way
Lebanon, New Jersey 08833
(800) 233-8493

PROJECT:	DRAWN BY:
CUSTOMER:	DATE:
ARCH'T:	DWG. NO:
AGENT:	SHEET OF