

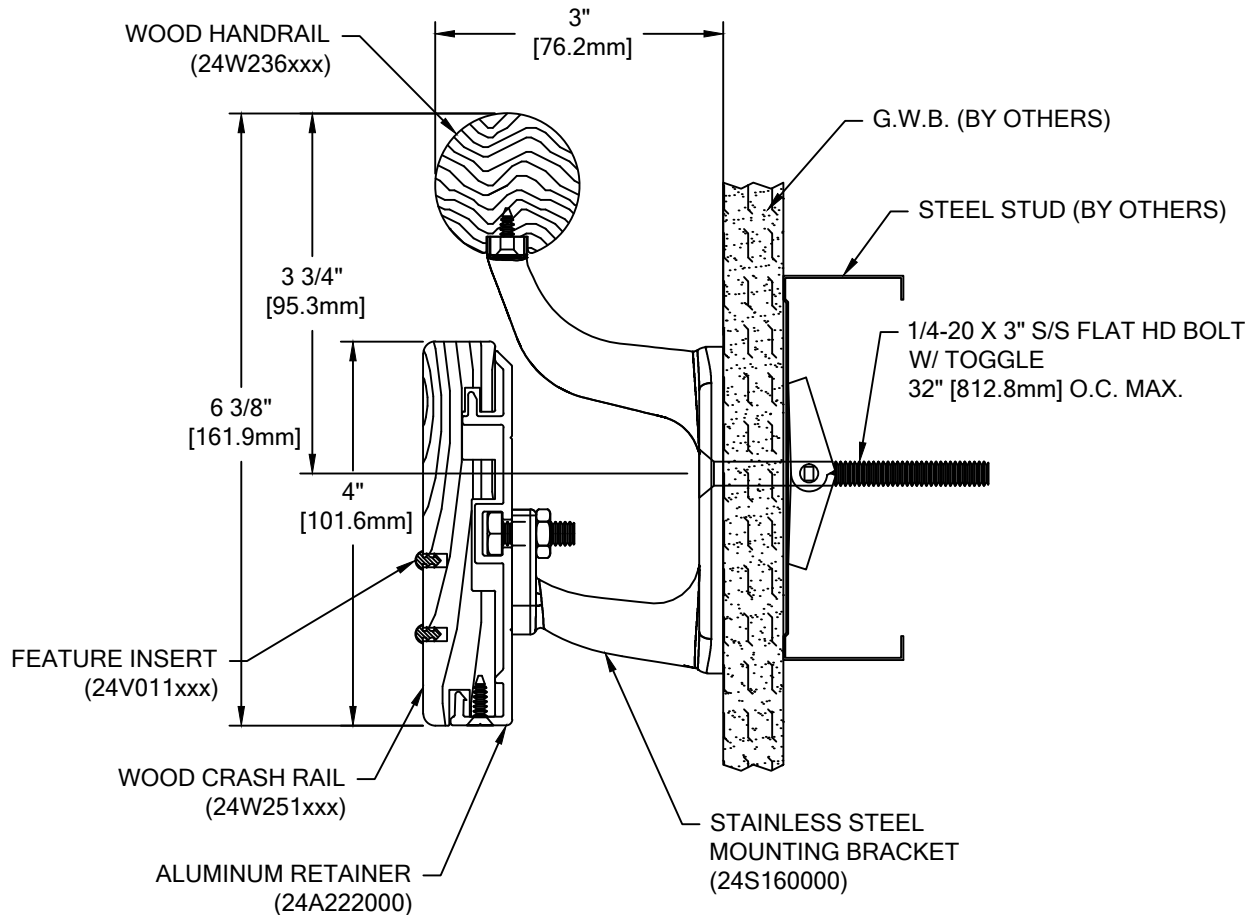

COLOR: \_\_\_\_\_  
 TOP RAIL WOOD SPECIES: \_\_\_\_\_  
 TOP RAIL WOOD FINISH: \_\_\_\_\_  
 BOTTOM RAIL WOOD SPECIES: \_\_\_\_\_  
 BOTTOM RAIL WOOD FINISH: \_\_\_\_\_  
 \*BRACKETS: \_\_\_\_\_  
 COLOR TO BE SELECTED FROM ONE OF C/S STANDARD COLORS.  
 \*BRACKETS ARE AVAILABLE WITH AN OPTIONAL POWDER COAT FINISH.  
 PLEASE ADVISE POWDER COAT FINISH IF REQUIRED.  
 FEATURE INSERT COLOR: \_\_\_\_\_

TOTAL L/F REQ'D	LEFT END CAPS	RIGHT END CAPS	O.S. REQ'D



# P-RWWW

WALL CONDITION	SPECIFIED FASTENER	DRILL DIAMETERS		C/S PART NUMBER
		WALL	RETAINER	
STEEL STUD/GYPSUM WALL	1/4-20 X 3" S/S FLAT HEAD BOLT WITH TOGGLE	3/4"	N/A	90H184002
CONCRETE/CONC. BLOCK	1/4" X 1 3/4" S/S FLAT HEAD MASONRY ANCHOR	3/16"	N/A	90H390000
WOOD STUD/GYPSUM WALL	#14 X 3" S/S PHILLIPS FLAT HEAD WOOD SCREW	7/32"	N/A	90H538004
20 GA. STEEL STUD/GYPSUM WALL (OSHPD)	1/4-20 X 3" S/S FLAT HEAD BOLT 1/4" TOGGLER WING 3M MOLDABLE FIRE PUTTY	1/2"	N/A	90H063002 90H062004 90M012000

 <p><b>Construction Specialties™</b>          6696 Route 405 Highway, Muncy PA 17756          (800) 233-8493 • Fax (570) 546-4692 • www.c-sgroup.com</p>	<b>PROJECT:</b>	<b>REVISION:</b>
	<b>JOB NO.:</b>	<b>F&amp;F:</b>
	<b>CUSTOMER:</b>	
	<b>REP:</b>	<b>DATE:</b>
	<b>DRAWN BY:</b>	<b>SHEET NO:</b>