

**P-OMS HANDRAIL**  
WITH INTERNATIONAL OFFSET

PLEASE READ

PLEASE READ THESE INSTRUCTIONS THOROUGHLY PRIOR TO BEGINNING THE P-OMS HANDRAIL INSTALLATION!

THIS INSTRUCTION SHEET IS INTENDED TO PROVIDE A SPECIFIC GUIDE TO FOLLOW FOR THE INSTALLATION OF THIS P-OMS HANDRAIL. CONTAINED WITHIN IS THE TECHNICAL INFORMATION AND INSTALLATION TECHNIQUES REQUIRED TO COMPLETE AN EFFICIENT, NEAT AND LONG-LASTING INSTALLATION.

INSPECT ALL MATERIALS FOR DAMAGE OR MISSING PARTS. IF YOU DISCOVER DAMAGED OR MISSING MATERIALS, IN THE USA PLEASE NOTIFY THE FACTORY AT (800) 233-8493, AND IN CANADA (888) 895-8955 FOR CUSTOMER SERVICE.

P-OMS HANDRAIL MUST BE INSTALLED IN ACCORDANCE WITH THESE INSTRUCTIONS! FAILURE TO FOLLOW THESE INSTRUCTIONS MAY VOID ANY PRODUCT WARRANTIES AND RESULT IN AN UNSUCCESSFUL INSTALLATION. FOR SPECIFIC QUESTIONS REGARDING THE INSTALLATION OF THIS P-OMS HANDRAIL PLEASE CALL THE FACTORY IN THE USA AT (800) 233-8493 OR EMAIL [IWPTECHSUPPORT@C-SGROUP.COM](mailto:IWPTECHSUPPORT@C-SGROUP.COM). IN CANADA CALL (888) 895-8955.

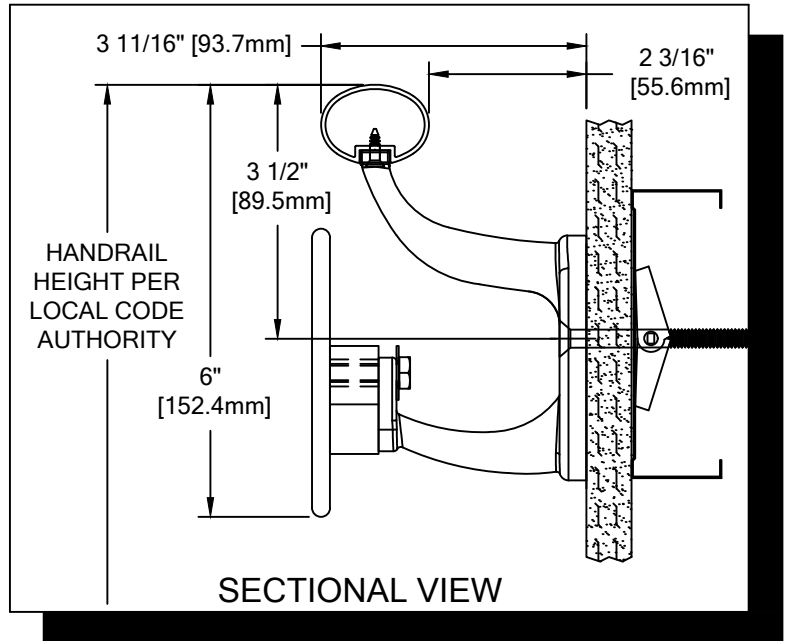

IMPORTANT NOTES

1. THIS HANDRAIL HAS BEEN MANUFACTURED TO CUSTOMER SPECIFIED DIMENSIONS AND CAN NOT BE CUT OR MODIFIED ON SITE. TO DO SO COULD VOID WARRANTY.
2. ALL DIMENSIONS ARE TYPICAL.
3. FOR DRYWALL/PLASTER WALL CONSTRUCTION, IT IS RECOMMENDED FOR FASTENERS TO BE ENGAGED INTO METAL/WOOD STUDS TO MAINTAIN MAXIMUM PULLOUT STRENGTH. IF DURING INSTALLATION YOU ENCOUNTER SPECIAL WALL CONDITIONS THAT DO NOT ALLOW FOR DIRECT ATTACHMENT TO THE STUDS PLEASE CONSULT THE LOCAL AUTHORITY HAVING JURISDICTION.
4. INSTALL OUTSIDE CORNERS FIRST.
5. INSTALL LONGEST RUN OF HANDRAIL FIRST.
6. POWDER COATED HANDRAIL SPLICE SHOULD NOT EXCEED 3" [76.2mm] DISTANCE FROM A BRACKET.
7. MATERIAL MUST REACH 65°F MIN. TO 75° MAX. 24 HOURS PRIOR TO INSTALLATION. THIS IS ESSENTIAL TO MINIMIZE EXPANSION AND CONTRACTION.
8. MAY REQUIRE USE OF FIRE PUTTY WHEN INSTALLED ON FIRE WALL WITH TOGGLE BOLTS. REFERENCE INSTRUCTIONS 24FIREPUTTY FOR FIRE PUTTY INSTALLATION.
9. THIS HANDRAIL REQUIRES A MINIMUM OF 2 MOUNTING BRACKETS PER UNIT. THE MINIMUM END CAP-TO-END CAP HANDRAIL LENGTH IS 16" [406.4mm].
10. FOR MORE INFORMATION ON P-OMS HANDRAIL SEE OUT WEBSITE AT [www.c-sgroup.com](http://www.c-sgroup.com).

**P-OMS HANDRAIL  
WITH INTERNATIONAL OFFSET**

COMPONENTS & WALL FASTENERS



POWDER COATED HANDRAIL  
(24A220xxx)



POWDER COATED  
HANDRAIL END CAP  
(24M066xxx)

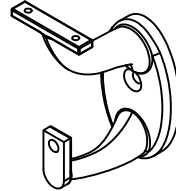

STAINLESS STEEL  
MOUNTING BRACKET  
(24S171000)  
ALUMINUM POWDER  
COATED BRACKET  
(24M994XXX)

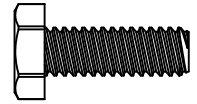

**FASTENER #1**  
1/4"-20 X 3/4" S/S  
HEX HEAD MACHINE SCREW  
(90H008006)

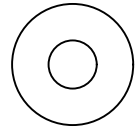

**FASTENER #2**  
1/4"-20 FLAT WASHER  
(90H007003)

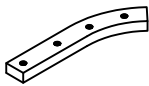

END CAP INSIDE  
MOUNTING PLATE  
(90H180010)

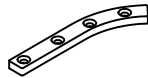

END CAP OUTSIDE  
MOUNTING PLATE  
(90H142010)

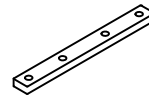

HANDRAIL SPLICE  
PLATE  
(90H150010)

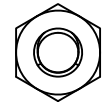

**FASTENER #3**  
1/4"-20 HEX NUT  
(90H010001)



STAINLESS STEEL  
CRASH RAIL

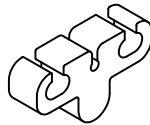

BRACKET ADAPTER PLATE  
(24F230003)



**FASTENER #4**  
#6-32 X 3/4" PHILLIPS S/S  
FLAT HEAD MACHINE SCREW  
(90H811002)

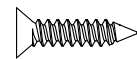

**FASTENER #5**  
#6 X 5/8" S/S PHILLIPS  
FLAT HEAD SMS  
(90H231004)

WALL CONDITION	SPECIFIED FASTENER	DRILL DIAMETERS		CS PART NUMBER
		WALL	RETAINER	
STEEL STUD/GYPSUM WALL	1/4-20 X 3" S/S FLAT HEAD BOLT WITH TOGGLE	3/4"	N/A	90H184002
CONCRETE/CONCRETE BLOCK	1/4" X 1 3/4" S/S FLAT HEAD MASONRY ANCHOR	3/16"	N/A	90H390000
WOOD STUD/GYPSUM WALL	#14 X 3" S/S PHILLIPS FLAT HEAD WOOD SCREW	7/32"	N/A	90H538004

**P-OMS HANDRAIL  
WITH INTERNATIONAL OFFSET**

LAYOUT VIEW

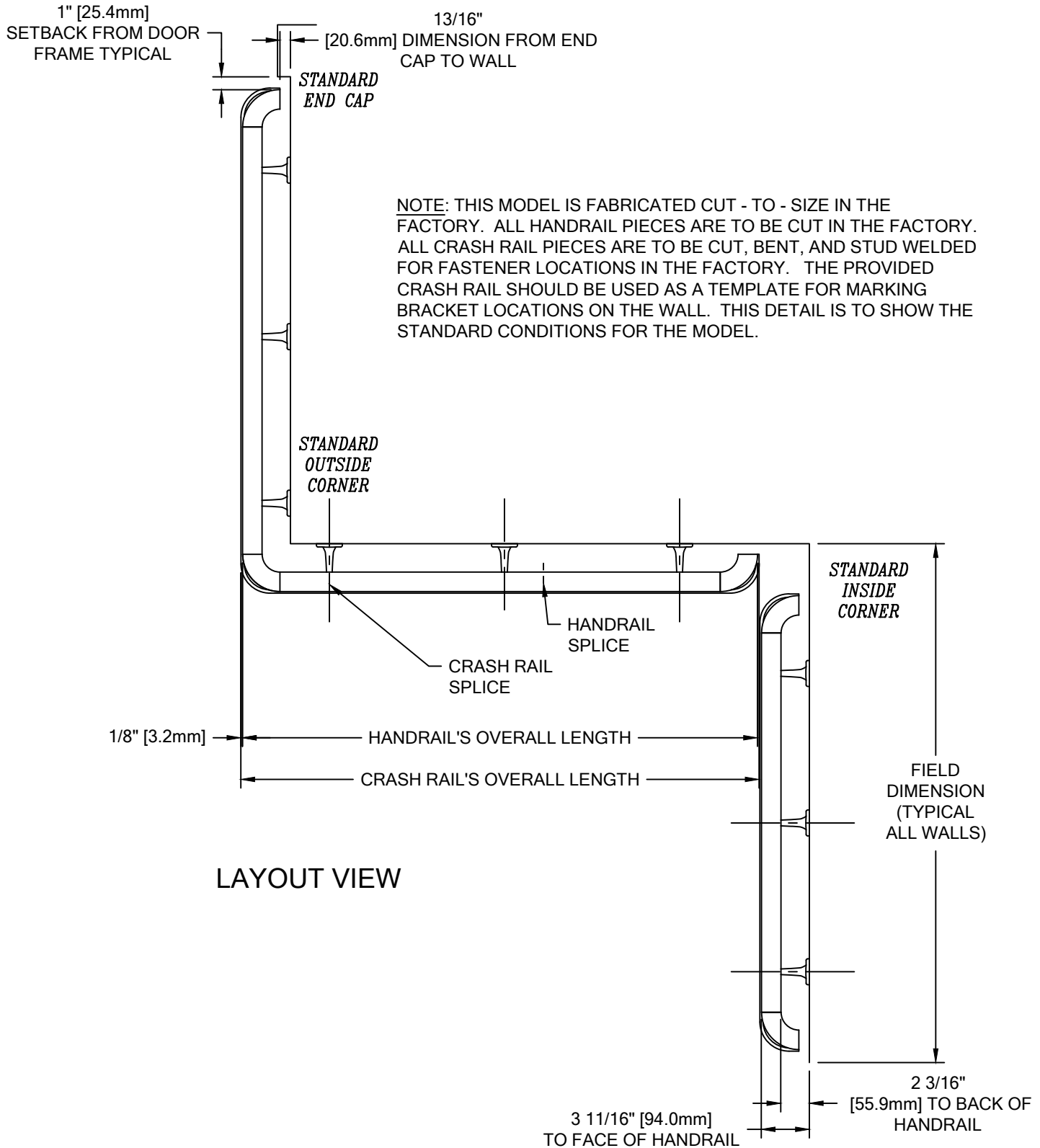

**P-OMS HANDRAIL  
WITH INTERNATIONAL OFFSET**

TYPICAL ASSEMBLY

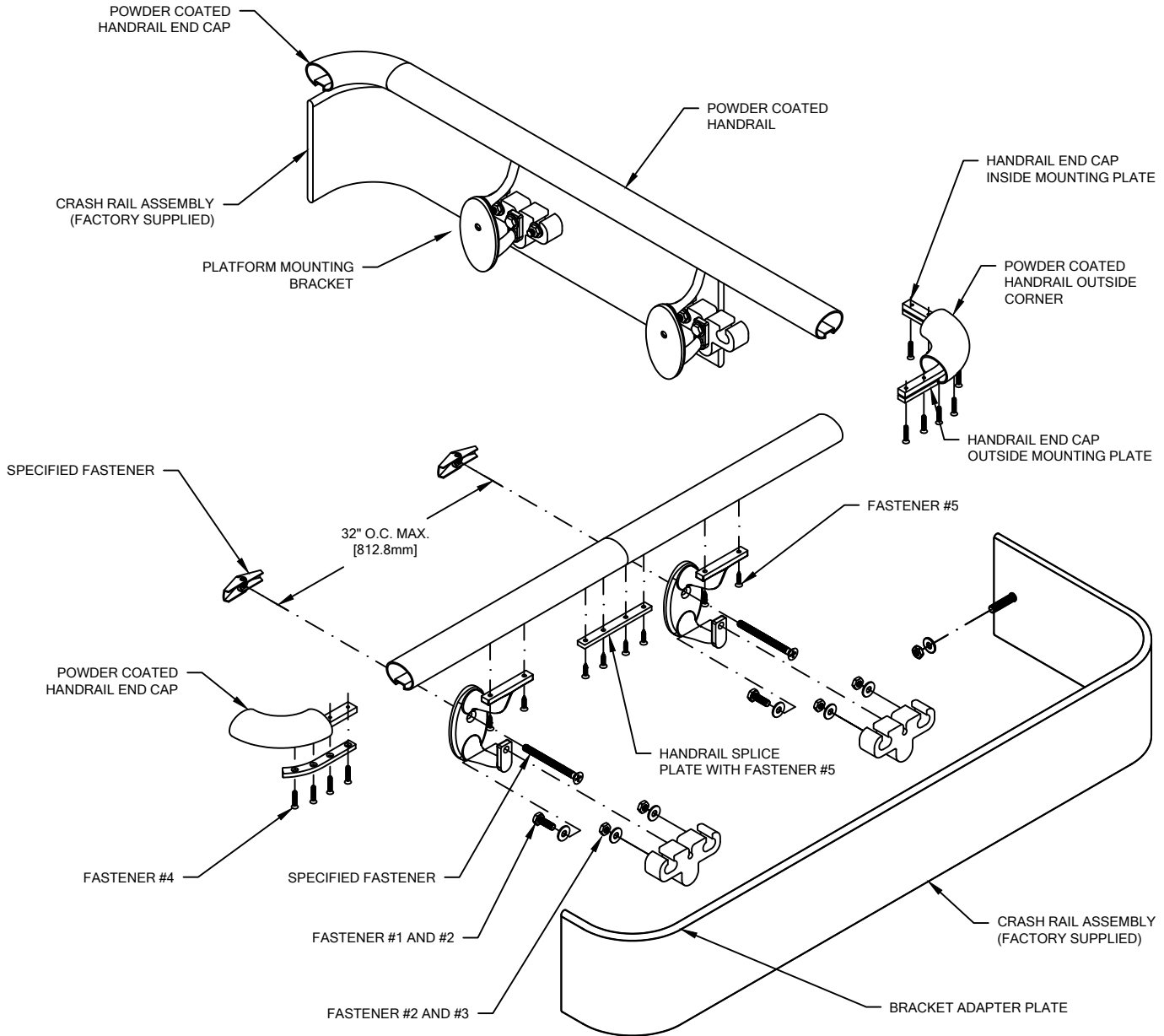

**P-OMS HANDRAIL  
WITH INTERNATIONAL OFFSET**

TYPICAL HANDRAIL ASSEMBLY

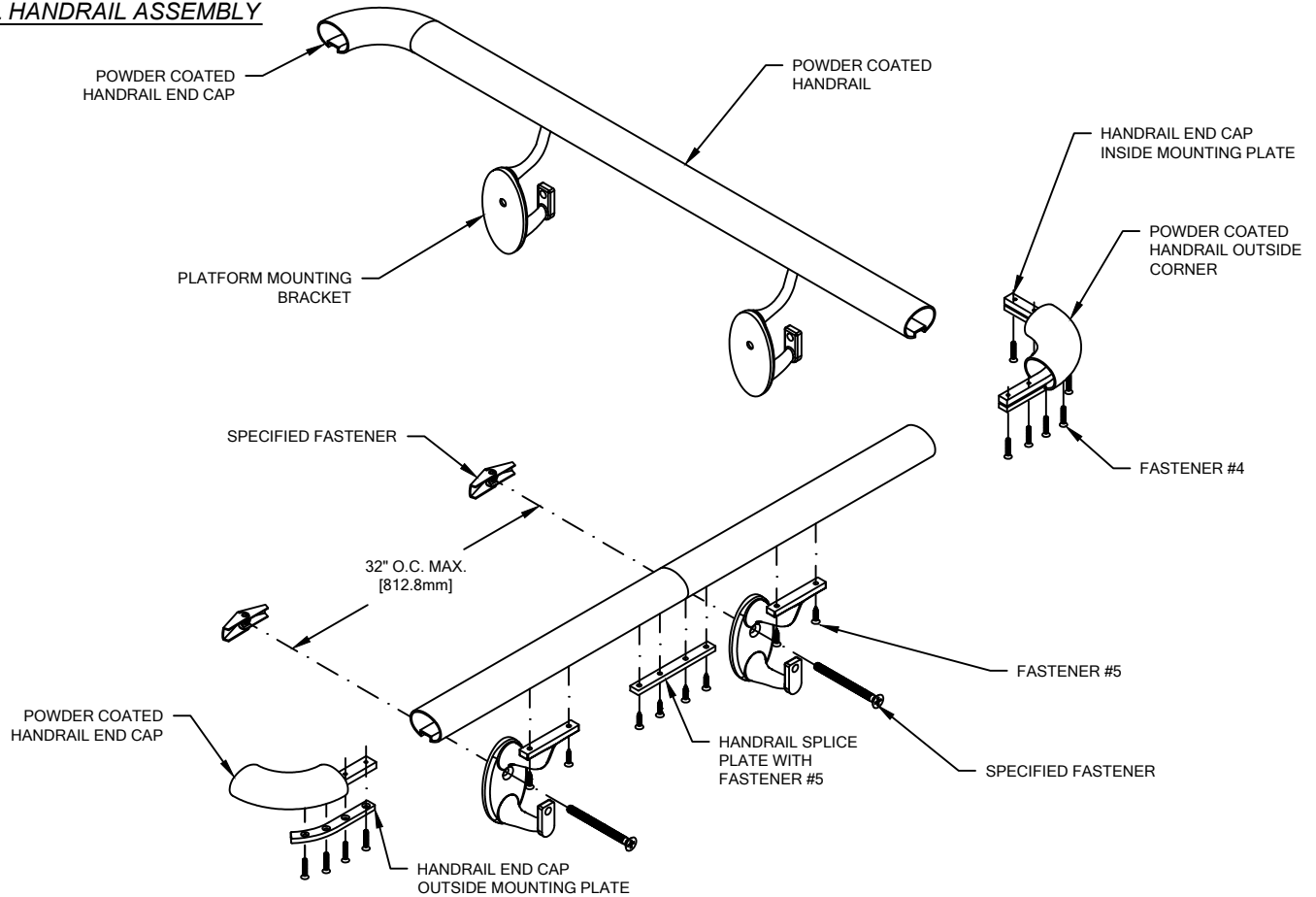

**NOTE:** THIS MATERIAL HAS BEEN MANUFACTURED TO CUSTOMER SPECIFIED DIMENSIONS AND CAN NOT BE CUT OR MODIFIED ON SITE. TO DO SO COULD VOID THE WARRANTY.

1. USING "LOCAL CODE" REQUIREMENTS, ESTABLISH HANDRAIL HEIGHT ABOVE FINISH FLOOR. DEDUCT 3 3/8" [85.7mm] AND SNAP A CHALK LINE AT THAT HEIGHT. THIS MARKS THE LOCATION OF THE HOLE FOR THE MOUNTING BRACKET FASTENERS.
2. DRILL CLEARANCE HOLES IN WALL SURFACE FOR MOUNTING HARDWARE. REFERENCE CHART ON PAGE 2 FOR CORRECT DRILL DIAMETERS. USE CRASH RAIL WITH ATTACHED BRACKETS AS A TEMPLATE TO MARK BRACKET LOCATIONS ON THE WALL (REFERENCE STEP #7).
3. INSTALL MOUNTING BRACKETS USING APPROPRIATE FASTENERS. USE A LEVEL TO ENSURE THAT THE BRACKETS ARE LEVEL. WARNING: MOUNTING BRACKET LOCATIONS MUST BE IDENTICAL TO THE FACTORY INSTALLED STUDS ON THE BACKSIDE OF THE CRASH RAIL.
4. ATTACH END CAPS AND OUTSIDE CORNERS:
  - ALIGN HANDRAIL WITH END CAP SO THEY ARE FLUSH TOGETHER.
  - USING OUTSIDE MOUNTING PLATE AS A TEMPLATE, PLACE INTO GROOVE AND MARK THE HOLE LOCATIONS.
  - REMOVE OUTSIDE MOUNTING PLATE AND DRILL HOLES (1/8" DRILL  $\phi$ ).
  - ALIGN HOLES OF INSIDE MOUNTING PLATE, HANDRAIL AND OUTSIDE MOUNTING PLATE.
  - ATTACH USING #6-32 X 3/4" FH MACHINE SCREWS. DO NOT FULLY SECURE.
  - REPOSITION END CAP AND ATTACH USING #6-32 X 3/4" FH MACHINE SCREWS.
  - SECURELY TIGHTEN ALL FASTENERS.
5. DRILL 1/16" PILOT HOLES INTO THE POWDER COATED HANDRAIL FOR MOUNTING BRACKET ATTACHMENT. MOUNTING BRACKETS ARE TO BE LOCATED 3" [76.2mm] FROM EACH END OF THE POWDER COATED HANDRAIL AND 32" [612.6mm] ON CENTER ALONG LENGTH, AS REQUIRED.
6. FASTEN THE POWDER COATED HANDRAIL TO THE WALL BRACKETS IN SUCCESSION BY INSERTING TWO #6 X 5/8" PHILLIPS FLAT HEAD SHEET METAL SCREWS THROUGH THE UNDERSIDE OF BRACKET INTO THE POWDER COATED HANDRAIL. CAUTION: OVER-TORQUEING MAY CAUSE THE FASTENERS TO STRIP.

**P-OMS HANDRAIL  
WITH INTERNATIONAL OFFSET**

TYPICAL CRASH RAIL ASSEMBLY

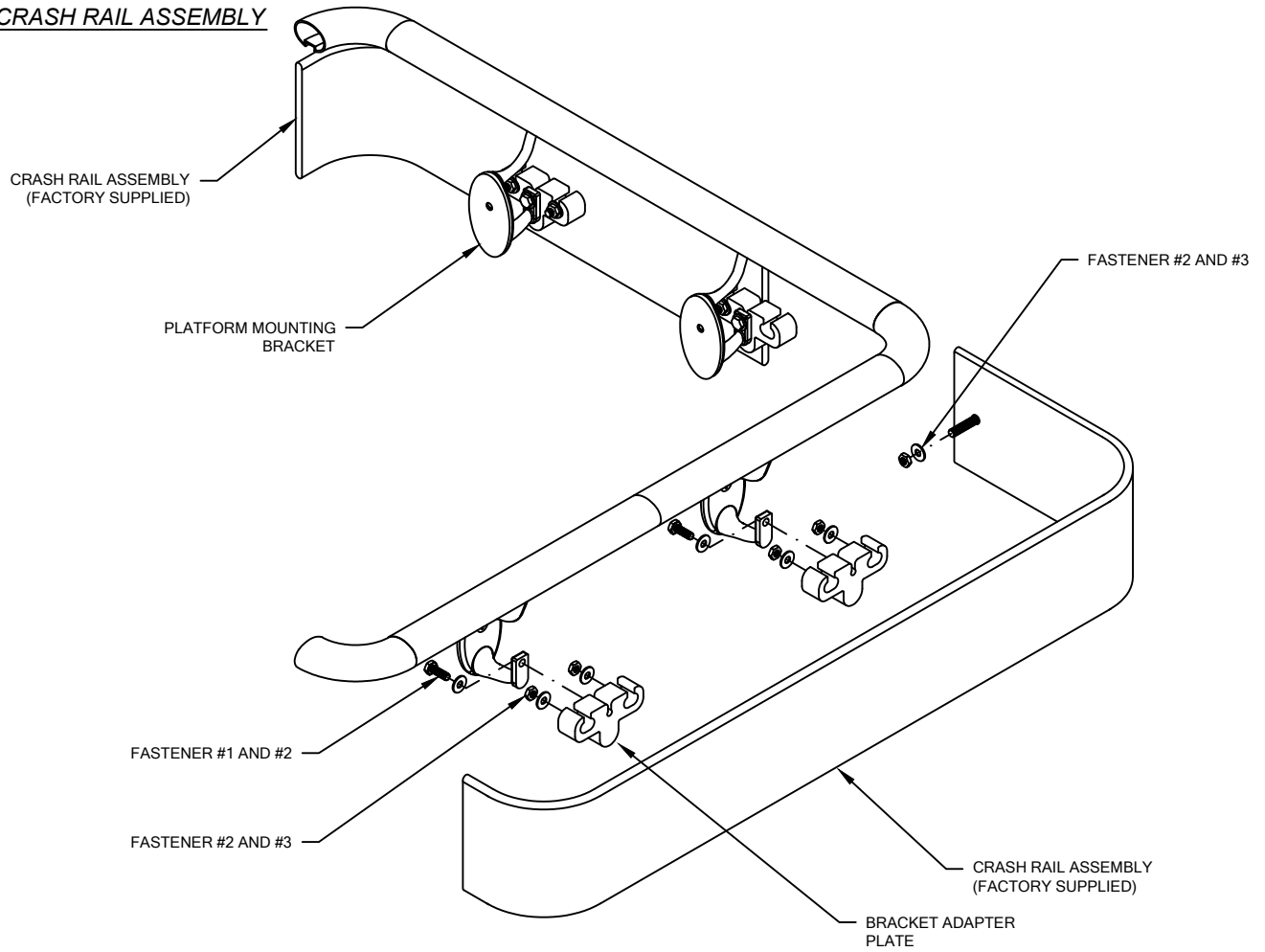

7. ATTACH CRASH RAIL TO THE WALL MOUNTING BRACKETS:
- DISTRIBUTE MATERIAL. MATCH THE NUMBER ON THE BACK OF THE RAIL TO THE MARK NUMBER ON THE DRAWING. SOME LARGE RUNS REQUIRE MORE THAN ONE PIECE OF CRASH RAIL. THESE ARE NOTED WITH A MARK NUMBER AND A LETTER, I.E., 2001A, 2001B.
  - LOCATE A BRACKET ADAPTER PLATE ON EACH SET OF THREADED STUDS ON THE BACKSIDE OF THE CRASH RAIL.
  - SECURE THE BRACKET ADAPTER PLATE BY INSTALLING A 1/4" WASHER AND 1/4-20 NUT ONTO EACH THREADED STUD.
  - ALIGN EACH MOUNTING BRACKET WITH THE BRACKET ADAPTER PLATE'S THREADED HOLE.
  - INSERT 1/4-20 HEX HEAD BOLT AND 1/4" WASHER THROUGH THE MOUNTING BRACKET AND INTO THE MOUNTING BRACKET'S THREADED HOLE. THE BRACKET ADAPTER PLATE IS SLOTTED TO ACCOMMODATE ANY SLIGHT MISALIGNMENT.
  - FASTENERS MUST BE TORQUED TO 150 IN/LBS.

7/18/18