

COLOR:

CORNER GUARD WOOD SPECIES: _____

CORNER GUARD WOOD FINISH: _____

*END CAPS: _____

COLOR TO BE SELECTED FROM ONE OF C/S STANDARD COLORS.

*END CAPS AND STAINLESS STEEL COVERS ARE AVAILABLE WITH AN OPTIONAL POWDER COAT FINISH. PLEASE ADVISE POWDER COAT FINISH IF REQUIRED. WOOD END CAPS ALSO AVAILABLE.

QTY. REQ'D	UNIT HEIGHT

NOTES:

1. THIS MODEL IS FABRICATED CUT-TO-SIZE, THEREFORE FIELD VERIFIED DIMENSIONS ARE REQUIRED.

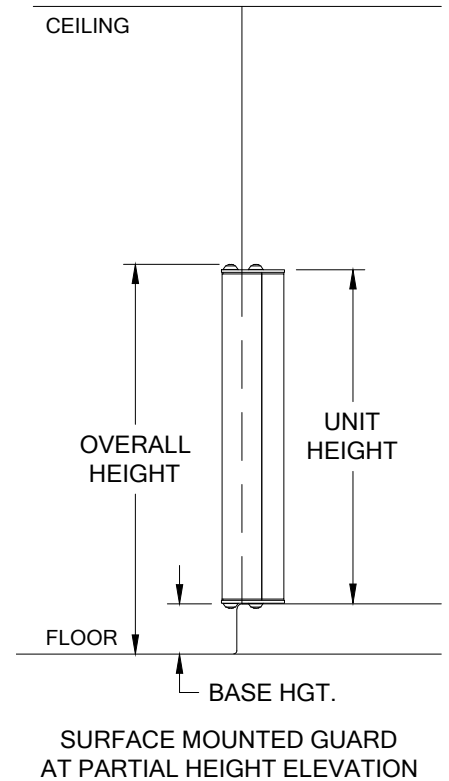
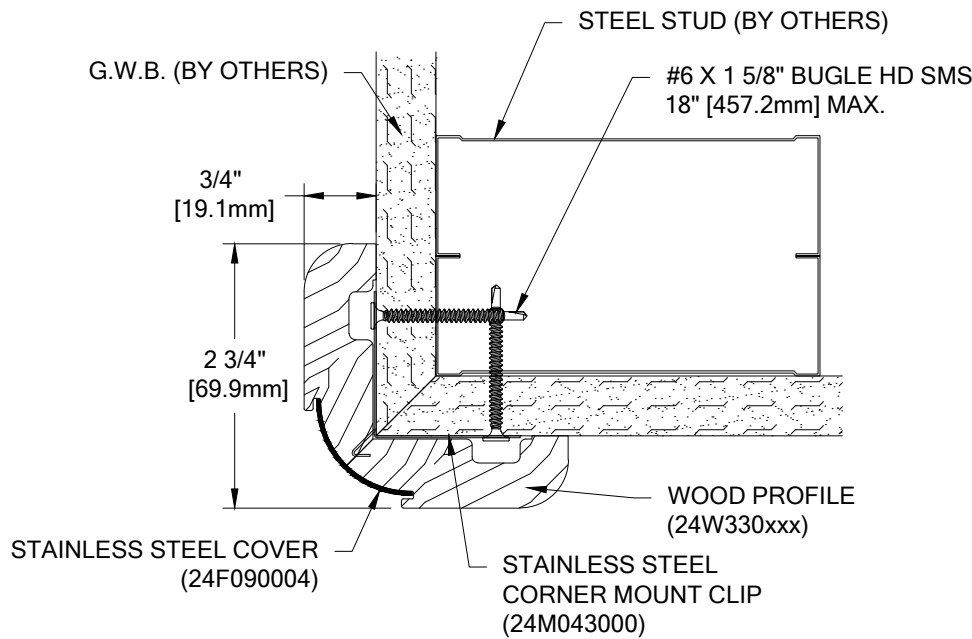

SMWS-10

WALL CONDITION	SPECIFIED FASTENER	DRILL DIAMETERS		C/S PART NUMBER
		WALL	RETAINER	
STEEL STUD/GYPSUM WALL	#6 X 1 5/8" BUGLE HEAD SMS	N/A	N/A	90H079002
WOOD STUD/GYPSUM WALL	#6 X 1 5/8" BUGLE HEAD SMS	N/A	N/A	90H079002
CONCRETE/CONC. BLOCK	AF-6 PLASTIC ANCHOR #10 X 1 1/2" PHILLIPS PAN HEAD SMS	1/4"	N/A	90H039004 90H189002

 Construction Specialties™ 6696 Route 405 Highway, Muncy PA 17756 (800) 233-8493 • Fax (570) 546-4692 • www.c-sgroup.com	PROJECT:	REVISION:
	JOB NO.:	F&F:
	CUSTOMER:	
	REP:	DATE:
	DRAWN BY:	SHEET NO: