

SMWS SERIES CORNER GUARD

PLEASE READ

PLEASE READ THESE INSTRUCTIONS THOROUGHLY PRIOR TO BEGINNING THE SMWS CORNER GUARD INSTALLATION!

THIS INSTRUCTION SHEET IS INTENDED TO PROVIDE A SPECIFIC GUIDE TO FOLLOW FOR THE INSTALLATION OF THIS SMWS CORNER GUARD. CONTAINED WITHIN IS THE TECHNICAL INFORMATION AND INSTALLATION TECHNIQUES REQUIRED TO COMPLETE AN EFFICIENT, NEAT AND LONG-LASTING INSTALLATION.

INSPECT ALL MATERIALS FOR DAMAGE OR MISSING PARTS. IF YOU DISCOVER DAMAGED OR MISSING MATERIALS, IN THE USA PLEASE NOTIFY THE FACTORY AT (800) 233-8493, AND IN CANADA (888) 895-8955 FOR CUSTOMER SERVICE.

SMWS CORNER GUARD MUST BE INSTALLED IN ACCORDANCE WITH THESE INSTRUCTIONS! FAILURE TO FOLLOW THESE INSTRUCTIONS MAY VOID ANY PRODUCT WARRANTIES AND RESULT IN AN UNSUCCESSFUL INSTALLATION. FOR SPECIFIC QUESTIONS REGARDING THE INSTALLATION OF THIS SMWS CORNER GUARD PLEASE CALL THE FACTORY IN THE USA AT (800) 233-8493 OR EMAIL IWPTECHSUPPORT@C-SGROUP.COM. IN CANADA CALL (888) 895-8955 .

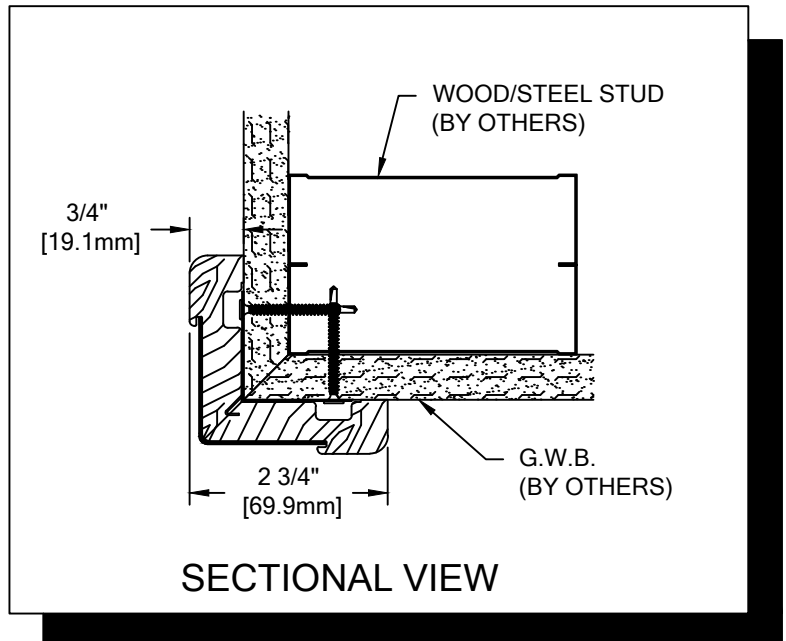

IMPORTANT NOTES

1. THIS MATERIAL HAS BEEN MANUFACTURED TO CUSTOMER SPECIFIED DIMENSIONS AND CAN NOT BE CUT OR MODIFIED ON SITE. TO DO SO COULD VOID THE WARRANTY.
2. ALL DIMENSIONS ARE TYPICAL.
3. FOR DRYWALL/PLASTER WALL CONSTRUCTION, IT IS RECOMMENDED FOR FASTENERS TO BE ENGAGED INTO METAL/WOOD STUDS TO MAINTAIN MAXIMUM PULLOUT STRENGTH.
4. MATERIAL MUST REACH 65°F MIN. TO 75°F MAX. 24 HOURS PRIOR TO INSTALLATION. THIS IS ESSENTIAL TO MINIMIZE EXPANSION AND CONTRACTION OF MATERIAL.
5. FOR MORE INFORMATION ON SMWS CORNER GUARD SEE OUR WEBSITE AT www.c-sgroup.com.

SMWS SERIES CORNER GUARD

LAYOUT VIEWS

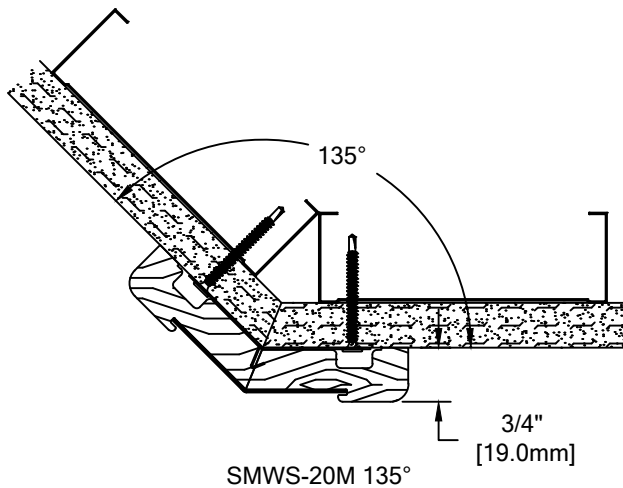
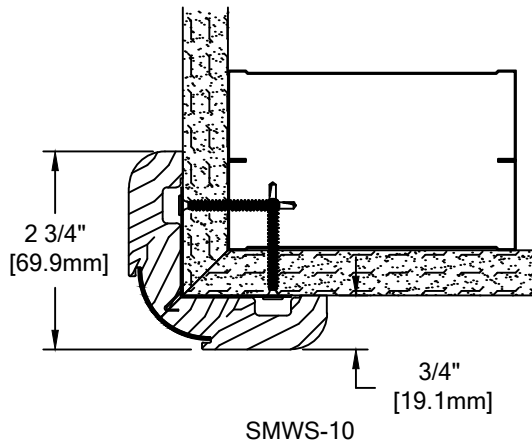
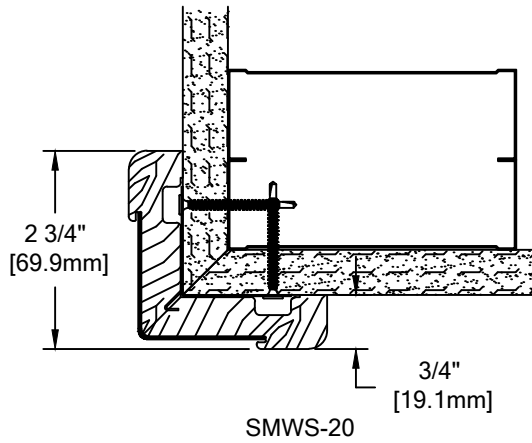

STANDARD DEDUCTIONS

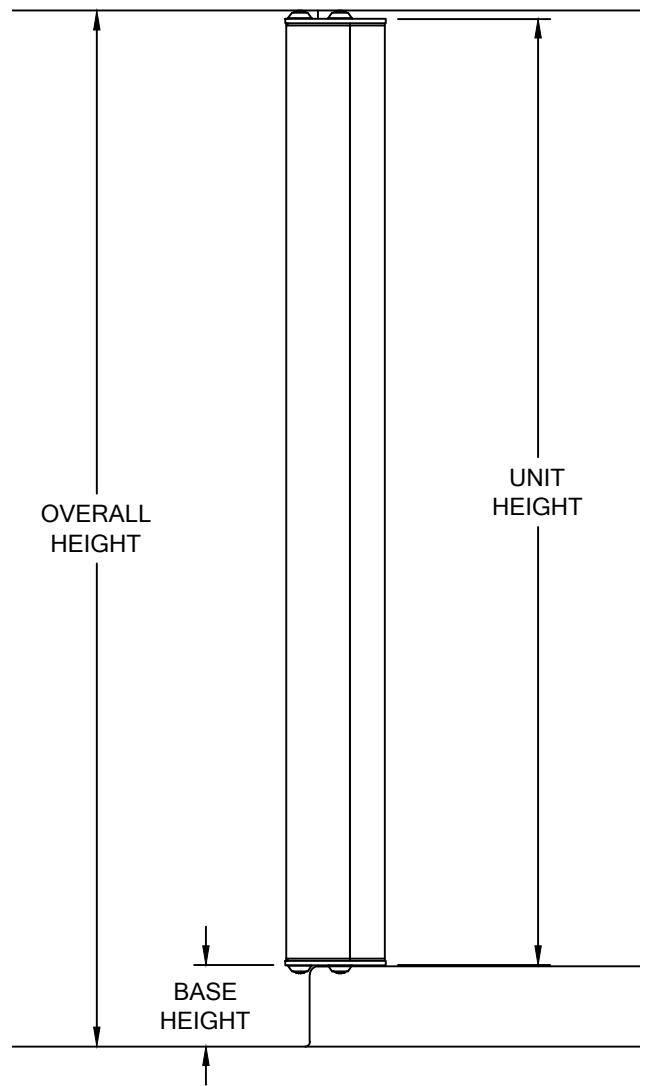

SMWS SERIES CORNER GUARD

COMPONENTS & WALL FASTENERS

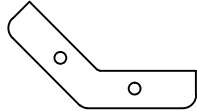

SMWS-20M 135° END CAP
STAINLESS STEEL (24S087000)
WOOD (24W361xxx)

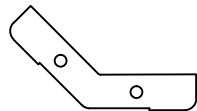

SMWS-20M 135°
ACCENT REVEAL
(24I106108)

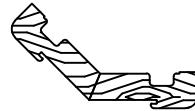

SMWS-20M 135°
WOOD PROFILE
(24W331xxx)

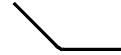

SMWS-20M 135°
STAINLESS STEEL COVER
(24F125004)

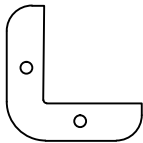

SMWS-10 END CAP
STAINLESS STEEL (24S084000)
WOOD (24W339xxx)

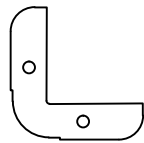

SMWS-10
ACCENT REVEAL
(24I103108)



SMWS-10
WOOD PROFILE
(24W330xxx)



SMWS-10
STAINLESS STEEL COVER
(24F090004)

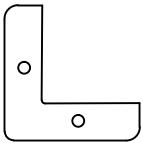

SMWS-20 END CAP
STAINLESS STEEL (24S085000)
WOOD (24W340xxx)

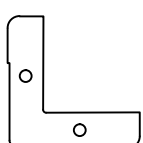

SMWS-20
ACCENT REVEAL
(24I105108)

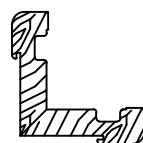

SMWS-20
WOOD PROFILE
(24W331xxx)



SMWS-20
STAINLESS STEEL COVER
(24F110004)

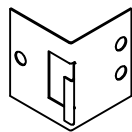

STAINLESS STEEL
CORNER MOUNT CLIP
(24M043000-90°)
(24M044000-135°)



FASTENER #1
#10 X 3/4"
OVAL HD S/S PH SMS
(90H459002)



FASTENER #2
#10 COUNTERSUNK
FLANGED S/S WASHER
(90H047003)

WALL CONDITION	SPECIFIED FASTENER	DRILL DIAMETERS		C/S PART NUMBER
		WALL	RETAINER	
STEEL STUD/GYPSUM WALL	#6 X 1 5/8" BUGLE HEAD SMS	N/A	N/A	90H079002
WOOD STUD/GYPSUM WALL	#6 X 1 5/8" BUGLE HEAD SMS	N/A	N/A	90H079002
CONCRETE/CONC. BLOCK	AF-6 PLASTIC ANCHOR #10 X 1 1/2" PHILLIPS PAN HEAD SMS	1/4"	N/A	90H039004 90H189002

SMWS SERIES CORNER GUARD

TYPICAL ASSEMBLY

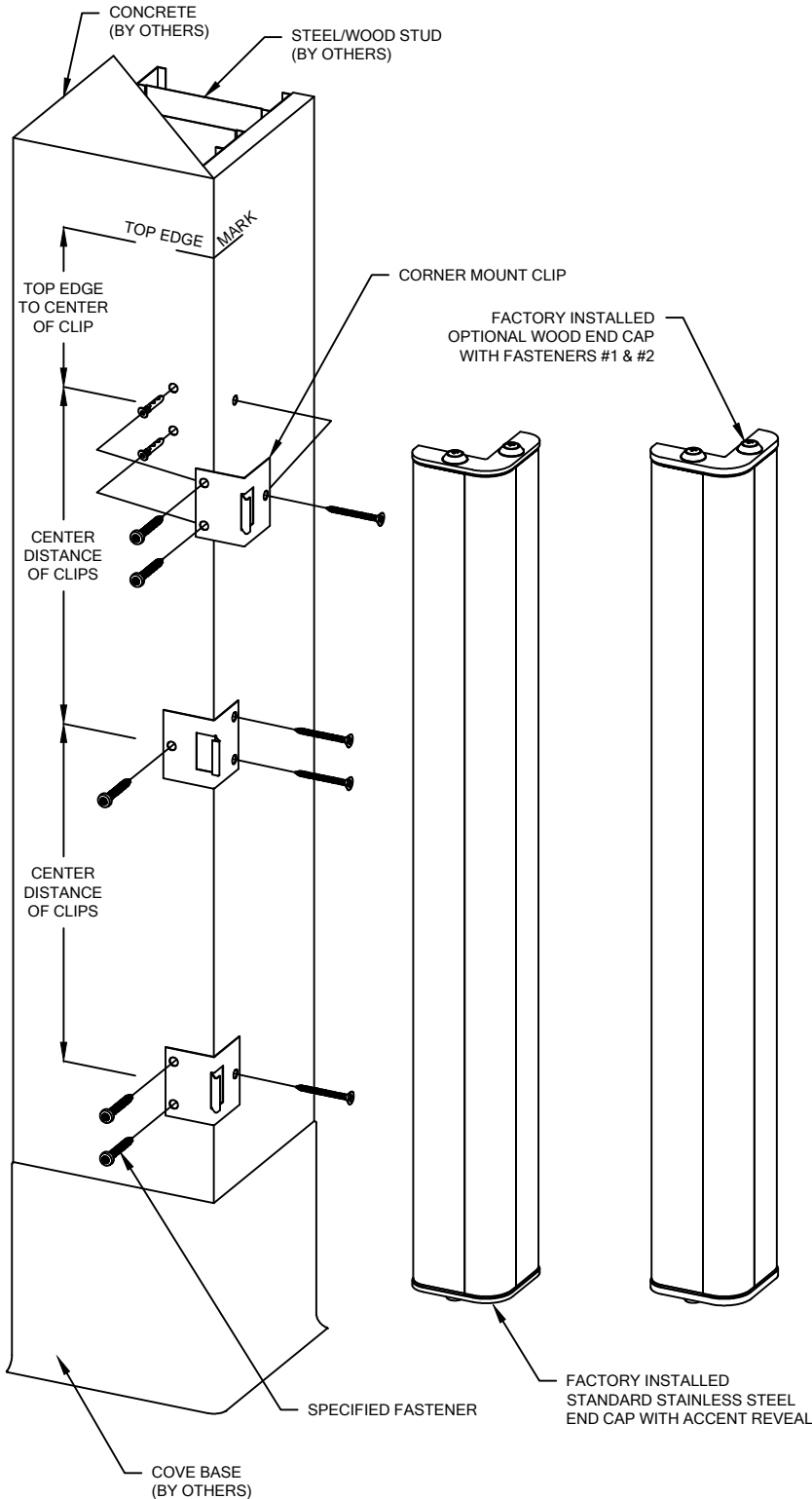

1. LOCATE AND INSTALL C/S CORNER GUARDS IN ACCORDANCE WITH ARCHITECTURAL DRAWINGS AND SPECIFICATIONS. WHEN REQUIRED, C/S SHOP DRAWINGS SHOULD BE USED IN CONJUNCTION WITH THESE DOCUMENTS.
 2. LAYOUT THE WORK TO BE COMPLETED, INCLUDING COMPONENT PARTS, AT EACH LOCATION TO RECEIVE CORNER GUARDS AS INDICATED BY THE C/S SHOP DRAWINGS. SPOT CHECK THE MATERIAL FOR ANY DAMAGE INCURRED DURING SHIPPING AND/OR HANDLING AT THE JOB SITE.
 3. DETERMINE DESIRED HEIGHT OF CORNER GUARD AND PENCIL MARK WALL TO INDICATE TOP EDGE OF CORNER GUARD.
 4. TO DETERMINE LOCATION OF CORNER MOUNT CLIPS ON WALL, MEASURE SLOT SPACING ON BACKSIDE OF CORNER GUARD. MEASURE TOP EDGE-TO CENTER AND CENTER-TO-CENTER DISTANCES OF EXISTING SLOTS AND TRANSFER TO WALL.
 5. CENTER CORNER MOUNT SLIPS ON TRANSFERRED MEASUREMENTS.
 6. DRILL CLEARANCE HOLES IN WALL SURFACE FOR MOUNTING HARDWARE, USING CORNER MOUNT CLIPS AS A TEMPLATE.
- NOTE:** CORNER MOUNT CLIPS MUST BE STAGGERED/ REVERSED AND SEATED TIGHT AGAINST THE WALL.
7. INSTALL EACH CORNER MOUNT CLIP, IN SUCCESSION, USING THE SPECIFIED FASTENERS.
- NOTE:** BE SURE CORNER MOUNT SLIPS ARE TIGHT AGAINST WALL AND IN CORRECT LOCATION. ONCE CORNER GUARD IS INSTALLED, IT WILL BE DIFFICULT TO REMOVE WITHOUT DAMAGING CORNER GUARD, WALL AND/OR CORNER MOUNT CLIPS.
8. POSITION CORNER GUARD IN ITS PROPER LOCATION AND BEGIN TO SEAT THE INDIVIDUAL CORNER MOUNT CLIPS BY CAREFULLY PUSHING/TAPPING ON THE CORNER GUARD.

4/9/13