

**Model RS-3700**  
**3" (76.2 mm) Storm Resistant Fixed Vertical Louver**

**Material:**

<b>Material:</b>	6063-T6 Alloy
<b>Nominal Thickness:</b>	Sills, Jambes & Mullions: 0.080" (2.03 mm) Heads & Sill Baffle: 0.060" (1.52 mm)
<b>Nominal Blade Thickness:</b>	0.050" (1.27 mm)
<b>Furnished With:</b>	Birdscreen: ½" intercrimp aluminum mesh, 0.063" diameter wire removeable aluminum bird screen in an aluminum frame
<b>Additional Options (at additional cost):</b>	Insect screen (in lieu of bird screen), Continuous clip angles for attachment Sheet blank off, Insulated blank off Sill pans, Flange frames Integrated glazing frames

**Test Summary:**

**For a 4 Foot by 4 Foot Unit.**

*Tested with mill finish and no screen \*and 1m<sup>2</sup> core area*

- Free area = 8.2 ft<sup>2</sup> (0.76 m<sup>2</sup>)
- Percent free area = 51.3%
- Free area velocity at the point of beginning water penetration (@ 0.01oz. / ft<sup>2</sup> of free area based on a 15 minute interval test) = 1250 FPM (6.35 m/s)
- Intake pressure drop at 0.01 oz. / ft<sup>2</sup> free area velocity = 0.289 in. H<sub>2</sub>O (71.8 Pa)
- To maintain a CLASS A (99%) effectiveness rating\* with:
  - a 29.1 mph wind speed and rainfall rate of 3 in/hr
    - Max. intake core velocity 5.0 m/s (984 FPM)
    - Max. intake free area velocity 8.1 m/s (1598 FPM)
- To maintain a CLASS A (99%) effectiveness rating\* with:
  - a 50 mph wind speed and rainfall rate of 8 in/hr
    - Max. intake core velocity 5.0 m/s (984 FPM)
    - Max. intake free area velocity 8.1 m/s (1598 FPM)

**Construction Specialties Inc. certifies that the louver model RS-3700 shown herein is licensed to bear the AMCA Certified Ratings Program Seal.** The ratings shown are based on tests and procedures performed in accordance with AMCA Publication 511 and comply with the requirements of the AMCA Certified Ratings Program. The AMCA Certified Ratings Seal applies to Wind Driven Rain ratings, Water Penetration Ratings and Air Performance ratings.

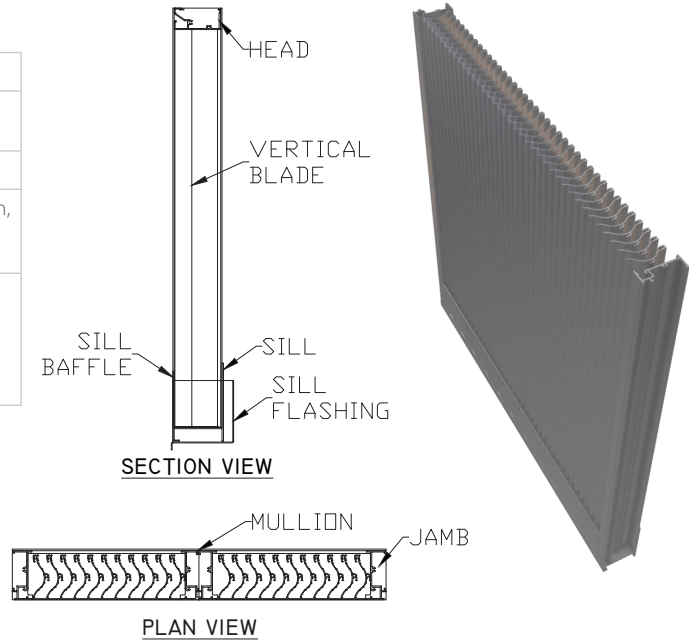

**Discharge Coefficient**

Intake Cd = 0.36 (Class 2)

AMCA certifies the coefficient class only

**Application and Design**

RS-3700 is tested in accordance with AMCA 500-L Air Performance, Water Penetration and Wind Driven Rain. RS-3700 is tested in accordance with AMCA 550 Test Method for High Velocity Wind Driven Rain Resistant Louvers. RS-3700 is tested in accordance with AMCA 540 Test Method for Louvers Impacted by Wind Borne Debris (Basic Protection, Missile Level D and Enhanced Protection, Missile Level E). Minimum louver section size to be 12"x12".

**Construction Specialties Inc. certifies that the louver model RS-3700 shown herein is approved to bear the AMCA Listing Label.**

The ratings shown are based on tests and procedures performed in accordance with AMCA Publications and comply with the requirements of the AMCA Listing Label Program. The AMCA Listing Label applies to High Velocity Wind Driven Rain Resistant Louvers in the fully open position that permits airflow through the louver. The AMCA Listing Label applies to pressure cycle tested Wind Borne Debris Impact Resistant Louvers rated for Enhanced Protection and +/- 100 PSF.



**Model RS-3700**  
**3" (76.2 mm) Storm Resistant Fixed Vertical Louver**

**Wind Driven Rain Performance:**

29.1 mph (13 m/s) & 8" (75 mm) rain per hour

Core Velocity Through Cal. Plate (m/s):	0.0	0.5	1.0	1.5	2.0	2.5	3.0	3.5	4.0	4.5	5.0
Core Velocity Through Louver (ft/min):	0	98	197	295	393	492	591	689	787	886	984
Free Area Velocity (ft/min):	0	159	320	479	638	799	959	1119	1278	1438	1598
Rating Effectiveness:	A	A	A	A	A	A	A	A	A	A	A
Effectiveness Ratio (%):									100	99.9	99.6

50 mph (22.3 m/s) & 8" (203 mm) rain per hour

Core Velocity Through Cal. Plate (m/s):	0.0	0.5	1.0	1.5	2.0	2.5	3.0	3.5	4.0	4.5	5.0
Core Velocity Through Louver (ft/min):	0	96	197	288	396	482	588	691	792	888	984
Free Area Velocity (ft/min):	0	156	320	468	643	783	955	1122	1286	1442	1598
Rating Effectiveness:	A	A	A	A	A	A	A	A	A	A	A
Effectiveness Ratio (%):										100	99.7
Effectiveness Rating:	A = 1 to 0.99			B = 0.989 to 0.95			C = 0.949 to 0.80			D = Below 0.80	

**Water Penetration Statement**

AMCA defines the point of beginning water penetration as the free area velocity at which the AMCA water test has yielded 0.01 or less ounces of water per square foot of louver free area during a 15-minute test period.

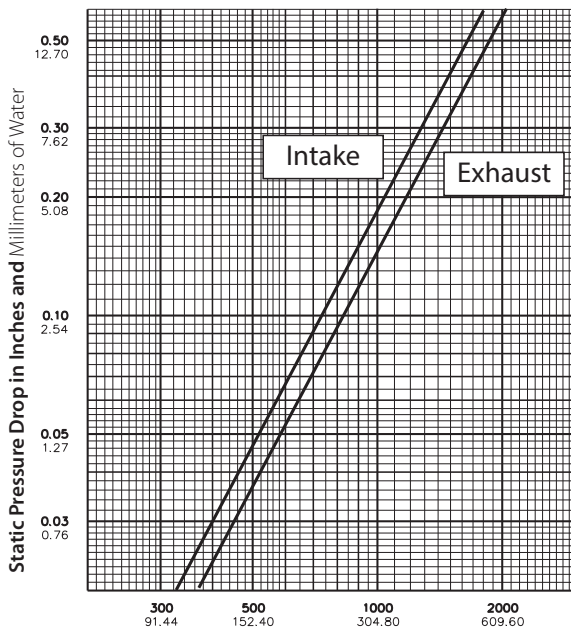

**Air Velocity in Feet and Meters per Minute Through Free Area**

Data corrected to standard air density.  
 48" x 48" louver tested to figure 5.5.

**Free Area Table** (Free area in sq. feet and sq. meters)

For additional sizes, please visit:

<https://www.c-sgroup.com/architectural-louvers/louvers-airflow-tool>

		Width in Inches and Meters										
		12	18	24	30	36	42	48	54	60	66	72
Height in Inches and Meters	0.30	0.46	0.61	0.76	0.91	1.07	1.22	1.37	1.52	1.68	1.83	
	<b>12</b>	<b>0.21</b>	<b>0.36</b>	<b>0.51</b>	<b>0.64</b>	<b>0.79</b>	<b>0.94</b>	<b>1.09</b>	<b>1.24</b>	<b>1.39</b>	<b>1.53</b>	<b>1.66</b>
	0.30	0.02	0.03	0.05	0.06	0.07	0.09	0.10	0.11	0.13	0.14	0.15
	<b>18</b>	<b>0.45</b>	<b>0.76</b>	<b>1.07</b>	<b>1.34</b>	<b>1.65</b>	<b>1.96</b>	<b>2.27</b>	<b>2.58</b>	<b>2.90</b>	<b>3.21</b>	<b>3.48</b>
	0.46	0.04	0.07	0.10	0.12	0.15	0.18	0.21	0.24	0.27	0.30	0.32
	<b>24</b>	<b>0.68</b>	<b>1.15</b>	<b>1.63</b>	<b>2.03</b>	<b>2.51</b>	<b>2.98</b>	<b>3.46</b>	<b>3.93</b>	<b>4.41</b>	<b>4.88</b>	<b>5.29</b>
	0.61	0.06	0.11	0.15	0.19	0.23	0.28	0.32	0.37	0.41	0.45	0.49
	<b>30</b>	<b>0.91</b>	<b>1.55</b>	<b>2.19</b>	<b>2.73</b>	<b>3.37</b>	<b>4.01</b>	<b>4.64</b>	<b>5.28</b>	<b>5.92</b>	<b>6.56</b>	<b>7.10</b>
	0.76	0.08	0.14	0.20	0.25	0.31	0.37	0.43	0.49	0.55	0.61	0.66
	<b>36</b>	<b>1.14</b>	<b>1.94</b>	<b>2.74</b>	<b>3.43</b>	<b>4.23</b>	<b>5.03</b>	<b>5.83</b>	<b>6.63</b>	<b>7.43</b>	<b>8.23</b>	<b>8.92</b>
	0.91	0.11	0.18	0.25	0.32	0.39	0.47	0.54	0.62	0.69	0.76	0.83
	<b>42</b>	<b>1.38</b>	<b>2.34</b>	<b>3.30</b>	<b>4.13</b>	<b>5.09</b>	<b>6.05</b>	<b>7.02</b>	<b>7.98</b>	<b>8.94</b>	<b>9.90</b>	<b>10.73</b>
	1.07	0.13	0.22	0.31	0.38	0.47	0.56	0.65	0.74	0.83	0.92	1.00
	<b>48</b>	<b>1.61</b>	<b>2.73</b>	<b>3.86</b>	<b>4.82</b>	<b>5.95</b>	<b>7.08</b>	<b>8.20</b>	<b>9.33</b>	<b>10.45</b>	<b>11.58</b>	<b>12.54</b>
	1.22	0.15	0.25	0.36	0.45	0.55	0.66	0.76	0.87	0.97	1.08	1.17
	<b>54</b>	<b>1.84</b>	<b>3.13</b>	<b>4.42</b>	<b>5.52</b>	<b>6.81</b>	<b>8.10</b>	<b>9.39</b>	<b>10.68</b>	<b>11.96</b>	<b>13.25</b>	<b>14.36</b>
	1.37	0.17	0.29	0.41	0.51	0.63	0.75	0.87	0.99	1.11	1.23	1.33
	<b>60</b>	<b>2.07</b>	<b>3.52</b>	<b>4.98</b>	<b>6.22</b>	<b>7.67</b>	<b>9.12</b>	<b>10.57</b>	<b>12.02</b>	<b>13.48</b>	<b>14.93</b>	<b>16.17</b>
	1.52	0.19	0.33	0.46	0.58	0.71	0.85	0.98	1.12	1.25	1.39	1.50
	<b>66</b>	<b>2.31</b>	<b>3.92</b>	<b>5.53</b>	<b>6.92</b>	<b>8.53</b>	<b>10.14</b>	<b>11.76</b>	<b>13.37</b>	<b>14.99</b>	<b>16.60</b>	<b>17.98</b>
1.68	0.21	0.36	0.51	0.64	0.79	0.94	1.09	1.24	1.39	1.54	1.67	
<b>72</b>	<b>2.54</b>	<b>4.31</b>	<b>6.09</b>	<b>7.61</b>	<b>9.39</b>	<b>11.17</b>	<b>12.94</b>	<b>14.72</b>	<b>16.50</b>	<b>18.27</b>	<b>19.80</b>	
1.83	0.24	0.40	0.57	0.71	0.87	1.04	1.20	1.37	1.53	1.70	1.84	
<b>78</b>	<b>2.77</b>	<b>4.71</b>	<b>6.65</b>	<b>8.31</b>	<b>10.25</b>	<b>12.19</b>	<b>14.13</b>	<b>16.07</b>	<b>18.01</b>	<b>19.95</b>	<b>21.61</b>	
1.98	0.26	0.44	0.62	0.77	0.95	1.13	1.31	1.49	1.67	1.85	2.01	
<b>84</b>	<b>3.00</b>	<b>5.11</b>	<b>7.21</b>	<b>9.01</b>	<b>11.11</b>	<b>13.21</b>	<b>15.32</b>	<b>17.42</b>	<b>19.52</b>	<b>21.62</b>	<b>23.42</b>	
2.13	0.28	0.47	0.67	0.84	1.03	1.23	1.42	1.62	1.81	2.01	2.18	
<b>90</b>	<b>3.24</b>	<b>5.50</b>	<b>7.77</b>	<b>9.71</b>	<b>11.97</b>	<b>14.24</b>	<b>16.50</b>	<b>18.77</b>	<b>21.03</b>	<b>23.30</b>	<b>25.24</b>	
2.29	0.30	0.51	0.72	0.90	1.11	1.32	1.53	1.74	1.95	2.16	2.34	
<b>96</b>	<b>3.47</b>	<b>5.90</b>	<b>8.32</b>	<b>10.40</b>	<b>12.83</b>	<b>15.26</b>	<b>17.69</b>	<b>20.12</b>	<b>22.54</b>	<b>24.97</b>	<b>27.05</b>	
2.44	0.32	0.55	0.77	0.97	1.19	1.42	1.64	1.87	2.09	2.32	2.51	
<b>102</b>	<b>3.70</b>	<b>6.29</b>	<b>8.88</b>	<b>11.10</b>	<b>13.69</b>	<b>16.28</b>	<b>18.87</b>	<b>21.46</b>	<b>24.05</b>	<b>26.64</b>	<b>28.86</b>	
2.59	0.34	0.58	0.83	1.03	1.27	1.51	1.75	1.99	2.23	2.48	2.68	
<b>108</b>	<b>3.93</b>	<b>6.69</b>	<b>9.44</b>	<b>11.80</b>	<b>14.55</b>	<b>17.31</b>	<b>20.06</b>	<b>22.81</b>	<b>25.57</b>	<b>28.32</b>	<b>30.68</b>	
2.74	0.37	0.62	0.88	1.10	1.35	1.61	1.86	2.12	2.38	2.63	2.85	
<b>114</b>	<b>4.17</b>	<b>7.08</b>	<b>10.00</b>	<b>12.50</b>	<b>15.41</b>	<b>18.33</b>	<b>21.24</b>	<b>24.16</b>	<b>27.08</b>	<b>29.99</b>	<b>32.49</b>	
2.90	0.39	0.66	0.93	1.16	1.43	1.70	1.97	2.24	2.52	2.79	3.02	
<b>120</b>	<b>4.40</b>	<b>7.48</b>	<b>10.56</b>	<b>13.19</b>	<b>16.27</b>	<b>19.35</b>	<b>22.43</b>	<b>25.51</b>	<b>28.59</b>	<b>31.67</b>	<b>34.31</b>	
3.05	0.41	0.69	0.98	1.23	1.51	1.80	2.08	2.37	2.66	2.94	3.19	

Upper Numerals English Units/Lower Numerals Metric Units