

MODEL AFW-X/AFWC-X

100 THRU 800

INSTALLATION INSTRUCTIONS

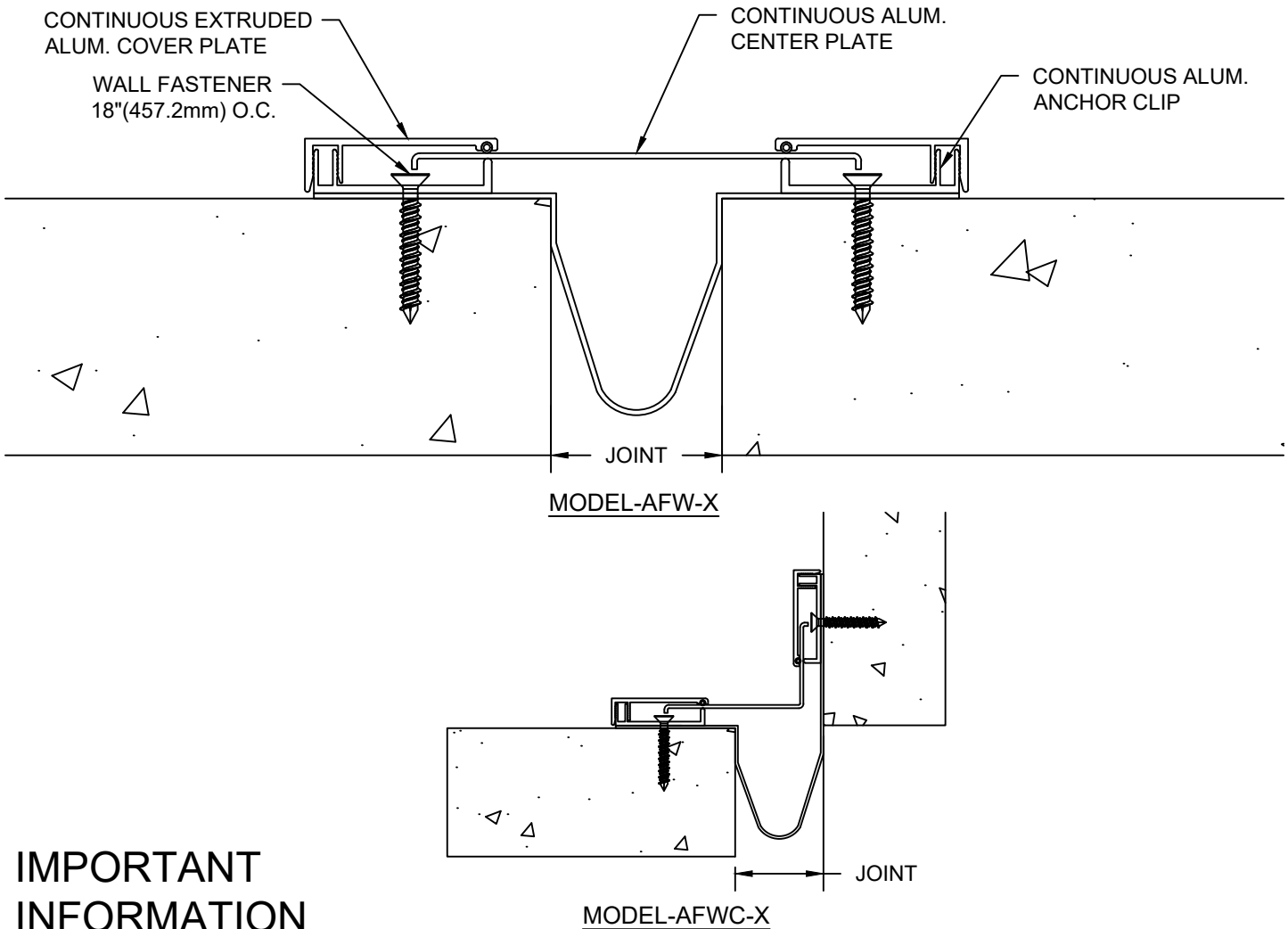

IMPORTANT INFORMATION

Prior to the commencement of Installation, all materials **MUST** be inspected for Damage. Any damage must be reported to CONSTRUCTION SPECIALTIES, INC., as soon as possible, so that replacement materials may be furnished without delay.

All work must be completed as per Architect's Approved "Shop Drawings", and in accordance with these Installation Instructions. When installation is complete, all materials must be protected from damage until the Architect's FINAL INSPECTION.

All materials should be arranged in the order that they are to be installed. All hardware required for each portion of the work should be placed with the appropriate materials.

Please review all Approved Shop Drawings and this Document to familiarize yourself with all the details and components of this assembly.

IMPORTANT:

READ THROUGH ALL INSTRUCTIONS PRIOR TO STARTING INSTALLATION

2/8/2024



Construction Specialties™

6696 Route 405 Highway, Muncy PA 17756

(800) 233-8493 Fax (570) 546-5169 www.c-sgroup.com

This document is the property of Construction Specialties, Inc. and contains CONFIDENTIAL PROPRIETARY INFORMATION that is not to be disclosed to third parties and is not to be used without approval in writing from Construction Specialties, Inc.

General Notes:

- *Before beginning installation, review the architectural drawings and approved Construction Specialties Inc. shop drawings to familiarize yourself with the appropriate joint cover models and locations.
- *The AFW-X series joint covers must be securely mounted to structurally sound substrates.
- *Check all the joint cover components to confirm that the correct joint cover model and size have been received. Also, check for materials that may have been damaged during shipping. Report all incorrect and/or damaged components to C/S at 800-233-8493.
- *Exterior wall cover supplied in 10" lengths, Vapor Barrier in 100' LF rolls.
- *Read through all the steps of these instructions prior to beginning work.
- *Remove protective coating from all parts **before** installation.

STEP 1

ANCHOR CLIP INSTALLATION

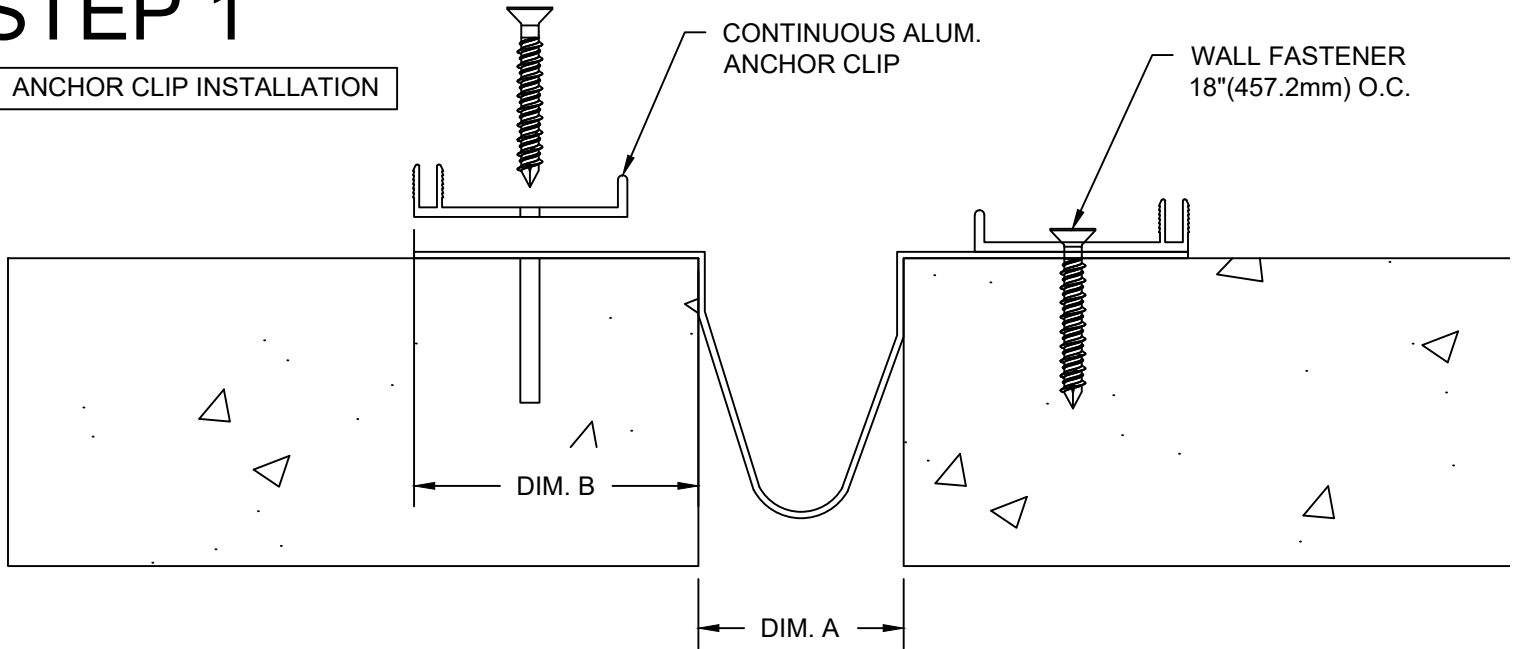

FRAME LOCATION DIMENSIONS		
DIM. A	DIM. B	DIM. C
1" [25.4mm]	1-7/8" [48.4mm]	2-5/8" [66.7mm]
2" [50.8mm]	2-3/4" [70.4mm]	3-5/8" [92.1mm]
3" [76.2mm]	3-3/4" [95.64mm]	5-7/8" [149.2mm]
4" [101.6mm]	3-3/4" [95.64mm]	5-7/8" [149.2mm]
5" [127mm]	3-7/8" [98.4mm]	5-7/8" [149.2mm]
6" [152.4mm]	3-7/8" [98.4mm]	5-7/8" [149.2mm]
7" [177.8mm]	5" [127mm]	5-7/8" [149.2mm]
8" [203.2mm]	5" [127mm]	5-7/8" [149.2mm]

MODEL-AFW-X

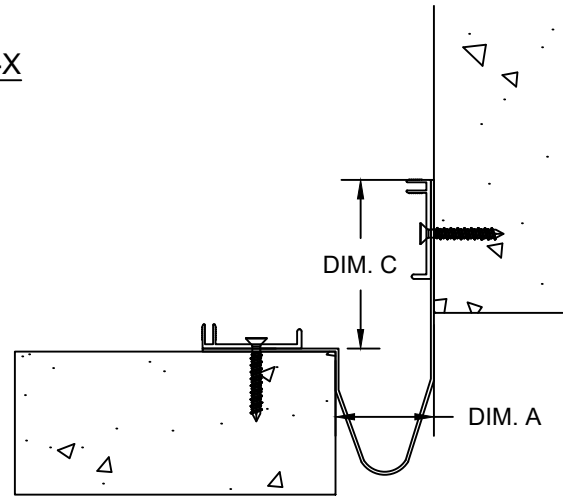

MODEL-AFWC-X

Note:

- If a C/S Fire Barrier is to be installed in the joint, please review the Fire Barrier Installation Instructions supplied, and if required install the Fire Barrier **BEFORE** installation of C/S Expansion Joint Cover.
- Begin installation of Expansion Wall Joint Cover by installing the Vapor Barrier first. Please review the Vapor Barrier Instructions supplied. The Vapor Barrier must be installed behind the anchor clips. CS recommends the installation of a base closure at the bottom of a run of exterior wall cover.

- 1.1) Begin installation of the Anchor Clips by snapping a plumb vertical chalk line at Dim. B & Dim. C. Note: The Anchor Clips must be installed plumb and square with chalk line to facilitate proper alignment and engagement of the Cover Plate. See Details above.
- 1.2) Attach the Anchor Clips to the wall at 18"(457.2mm) o.c. maximum, with the appropriate C/S supplied anchors.
- 1.3) Repeat the installation procedures for the opposite side of the joint if required.

STEP 2

CENTER PLATE INSTALLATION

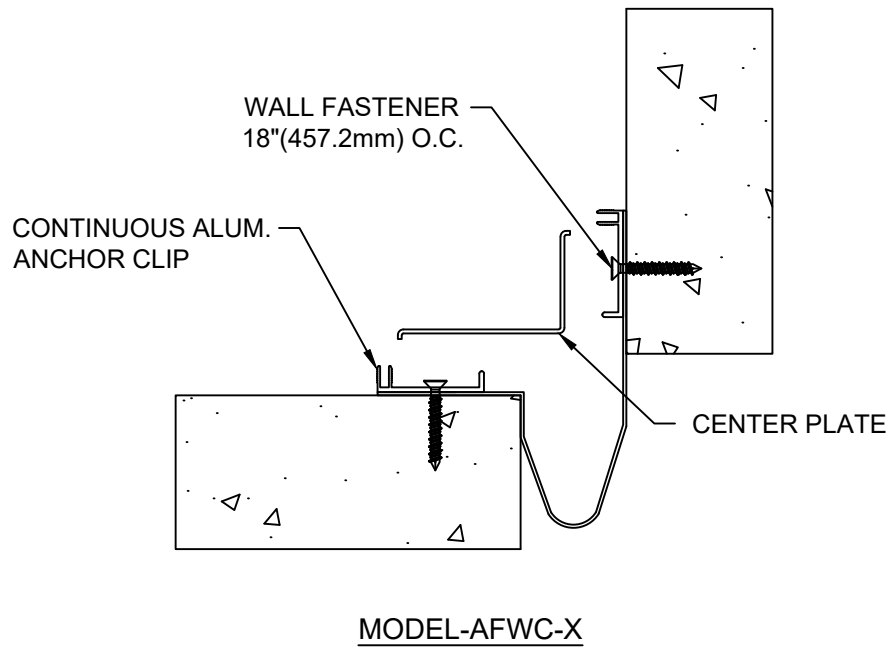
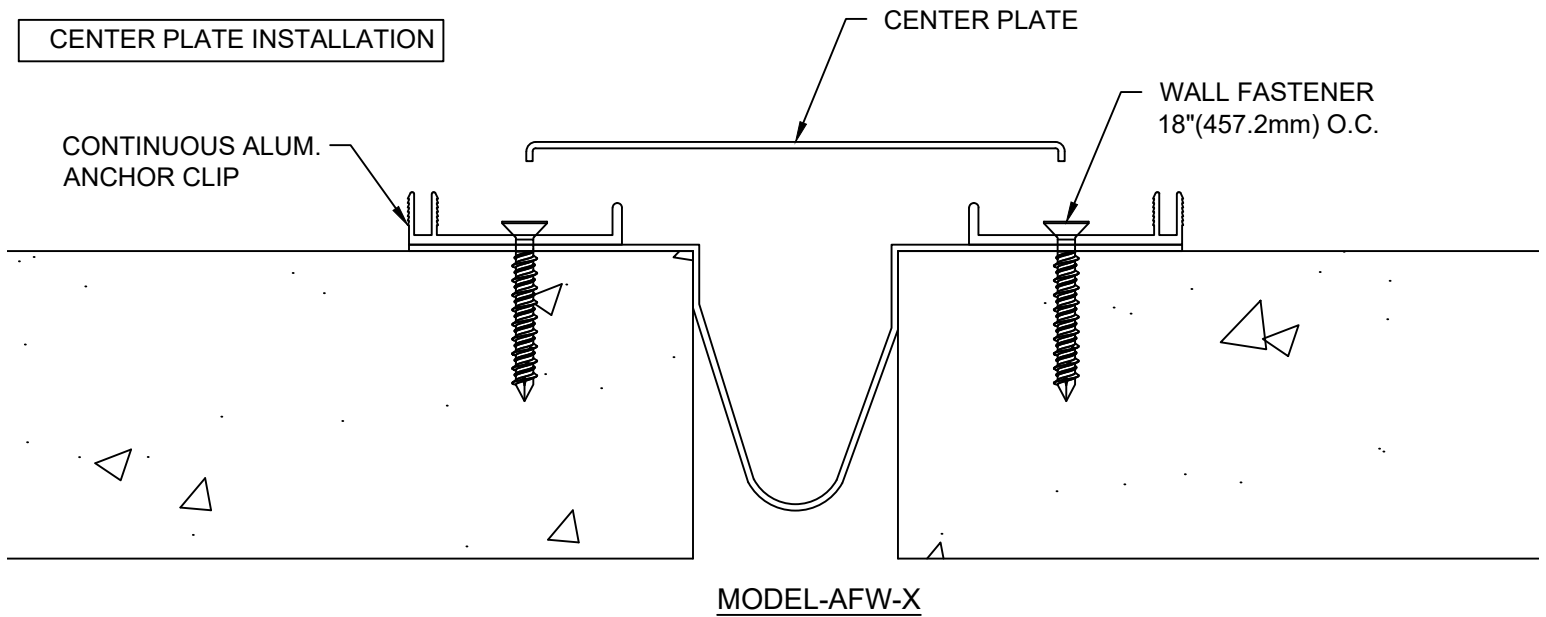

Note: Allow 3/8" gap at the bottom and at the top of each center plate run. No gap is required on a single 10' LF run length.

- 2.1) Begin installation of the Center Plate by first cutting the Plate to length as needed.
- 2.2) Place Center Plate on top of the Anchor Clips, keeping it centered over the joint, as shown above.

STEP 3

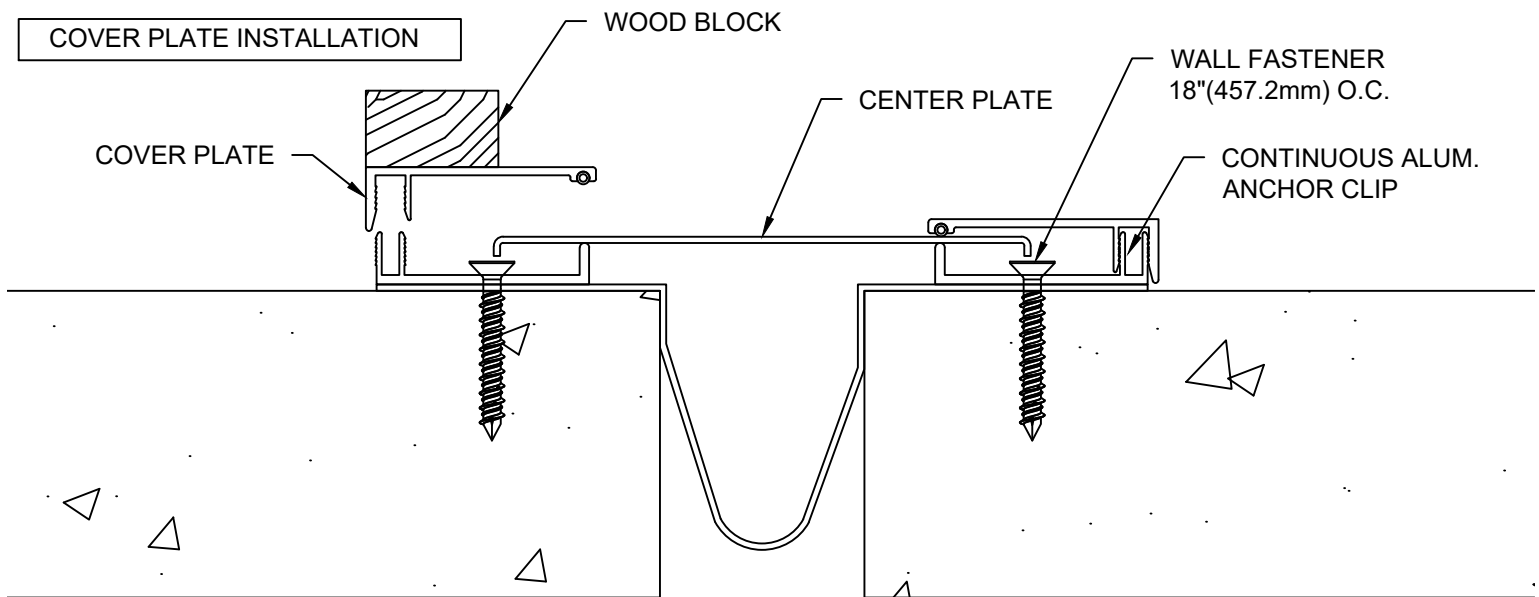

MODEL-AFW-X

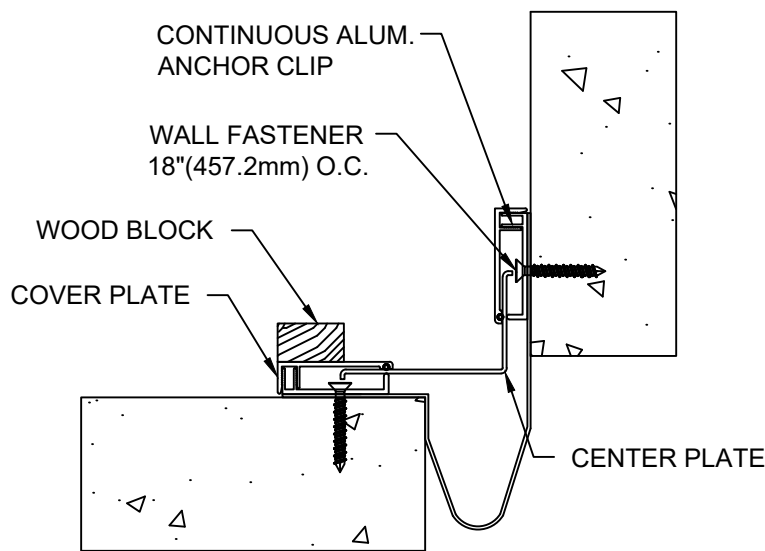

MODEL-AFWC-X

- 3.1) Begin installation of the Cover Plate to anchor clips by aligning one end of a length of Cover Plate with the end of the installed anchor clips. Anchor Clip and Cover Plate each need to align and be of the same length. Aligning with each other having no staggered installation from one to the other.
- 3.2) Place a wood block on top of the Cover Plate. While holding the Cover Plate somewhat level, use a rubber mallet to strike the wood block. (Note: Do not hammer directly onto the Cover Plates as this may cause damage to the Cover Plate.)
- 3.3) Work down along the length of the Cover Plate driving the Cover Plate approx. half onto the Anchor Clips. Then return and drive the Cover Plate the remainder of the way in until the Cover Plate is seated flush with the wall.
- 3.4) Repeat these procedures for the opposite side of the joint and for any additional lengths of Cover Plate.
Note: For each assembled panel system, Continuous Anchor Clip and Cover Plate, leave 1/8" gap between each section and 3/8" at the top and bottom of each run to allow for thermal expansion.

STEP 4

COMPLETE INSTALLATION

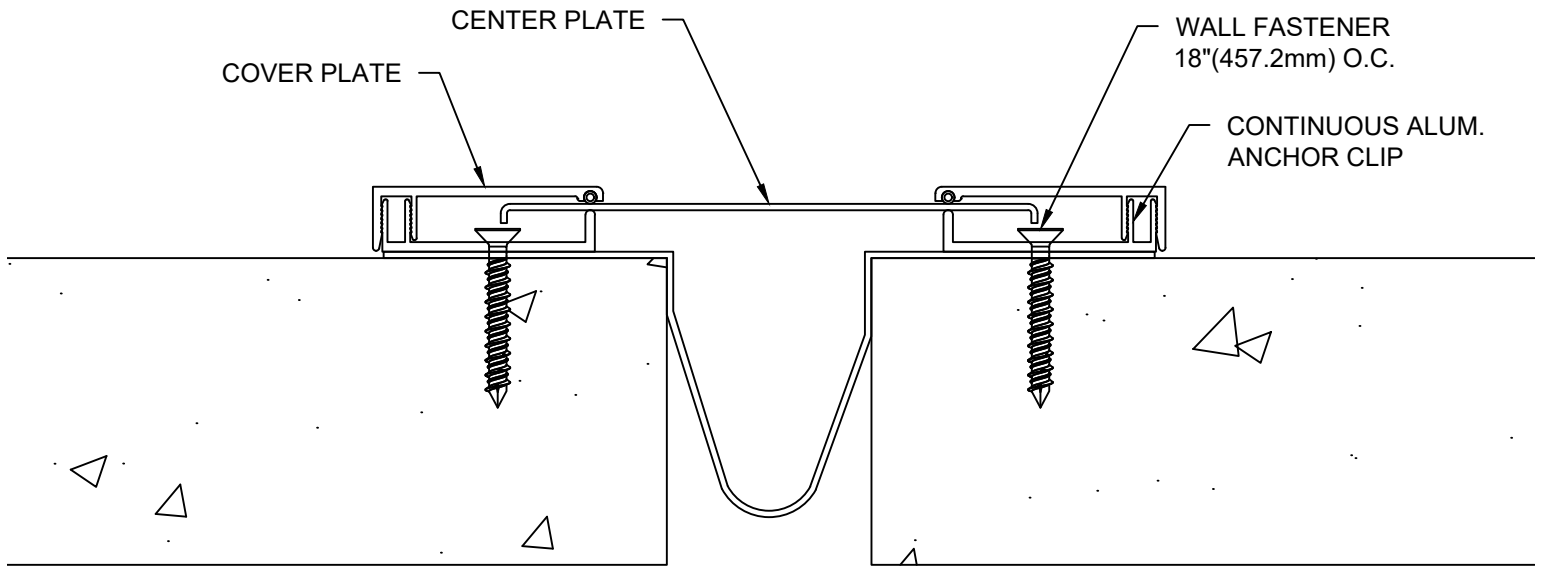

MODEL-AFW-X

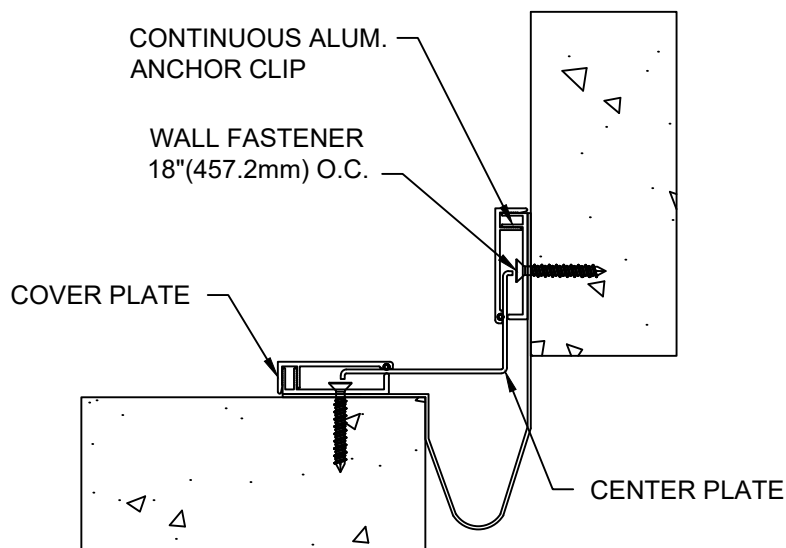

MODEL-AFWC-X

- 4.1) When installation of the C/S Wall Expansion Joint Cover has been completed, remove all residue and foreign matter from the area and joint cover.
- 4.2) Clean the C/S Joint Cover and adjoining surfaces with proper cleaner.
- 4.3) Protect the Joint Cover until the Architect's final inspection.