

**PEDIMAT WITH RECESSED TAPERED ANGLE FRAME**



INSERT STYLE:

INSERT COLOR: PLEASE ADVISE

CATALOG NUMBER: M1

PART NUMBER:

NO.	REVISION	DATE	BY
NO.	F&F RELEASE	DATE	BY

-   
**EXTERIOR CARPET**  
 M1EC  
 19C018XXX
-   
**HEAVY-DUTY CARPET**  
 M1HC  
 19C010XXX
-   
**RUBBER M1V**  
 19V022501  
 #8501 BLACK

**PEDIMAT INSERT STYLES**

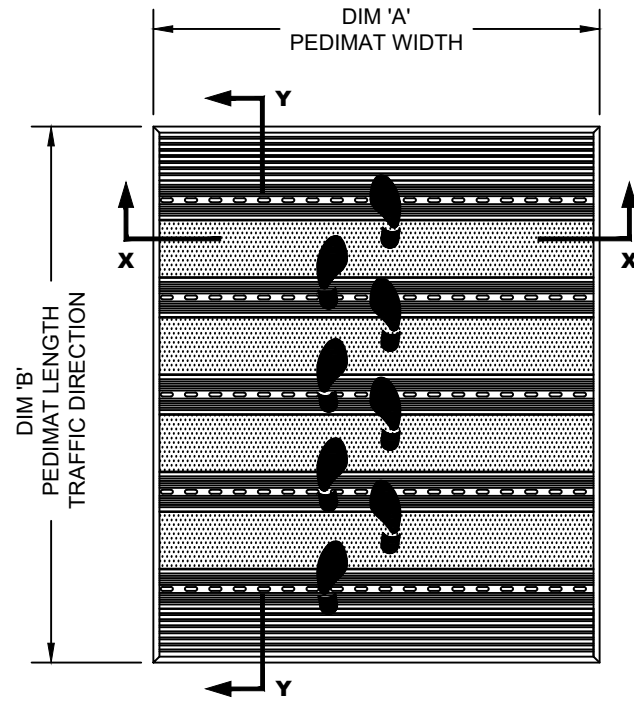

**TYPICAL PLAN VIEW**

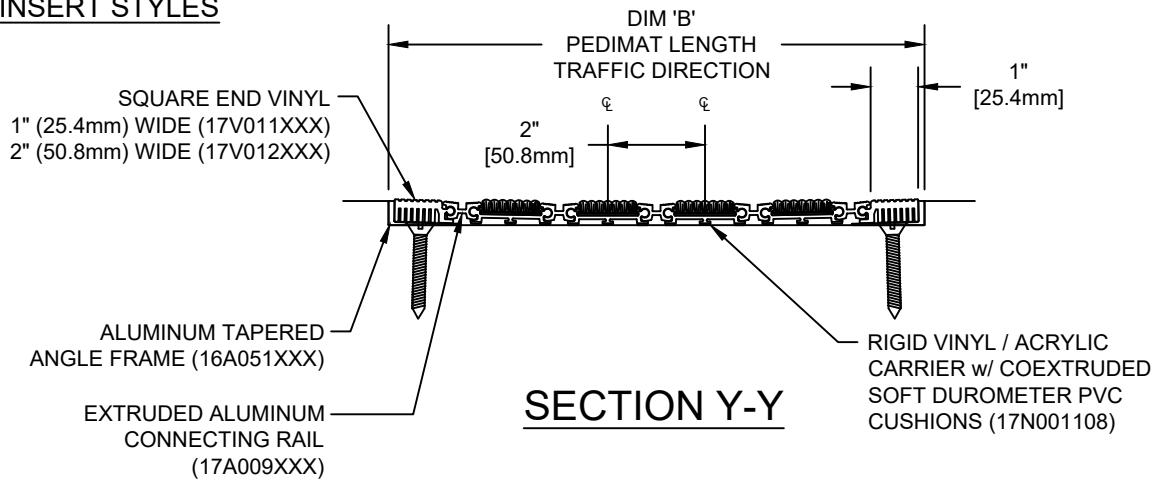

**SECTION Y-Y**

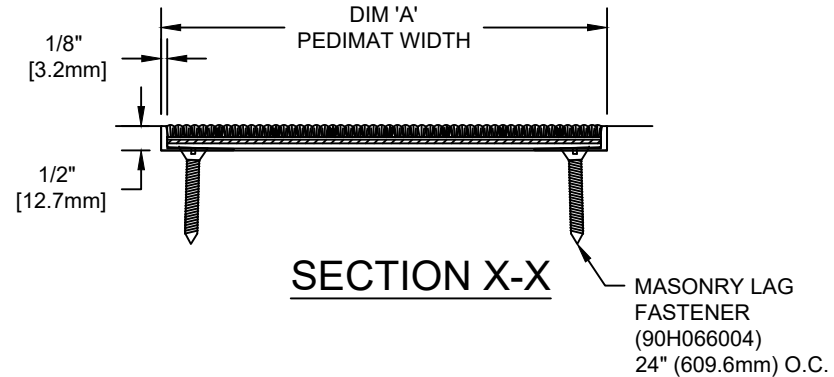

**SECTION X-X**

**NOTES:**

\*ALL SURFACES IN CONTACT WITH MASONRY ARE TO RECEIVE A COAT OF ZINC CHROMATE PRIMER

\*PLEASE VERIFY TRAFFIC DIRECTION

\*PEDIMAT SHALL BE ABLE TO SUPPORT A 350 LB. ROLLING LOAD. LARGER LOADING MAY BE ACCOMMODATED. CONTACT C/S SALES WITH SPECIFIC LOADING REQUIREMENTS.

\*MAX. SINGLE GRID SIZE NOT TO EXCEED 12'-0" (3.66M) IN WIDTH (DIM "A") OR 100 SQUARE FEET

\*ADDITIONAL SPECIFICATIONS ARE CONTAINED IN THE LATEST C/S CATALOG OR AT C-SGROUP.COM AND ARE CONSIDERED PART OF THIS TRANSMITTAL.



6696 Route 405 Highway, Muncy PA 17756  
(800) 233-8493 • Fax (570) 546-4692 • www.c-sgroup.com

PLEASE VERIFY ALL	QTY	MARK #	LOCATION	MODEL	DIM 'A' WIDTH	DIM 'B' LENGTH	FINISH	NOTES

PROJECT:		
LOCATION:		
CONTRACTOR:		
AGENT:		SHT:
DRG. BY:	DATE:	JOB NO.: