

GFST & GFSTW

TECHNICAL DATA:

Aluminum

- Extrusion – CS uses multiple alloys & tempers which are established to be the most appropriate for the given use of individual parts. Will be one of the following: (6063-T5, T6, T52) (6061-T5, T6, T51) (6105-T5, T6) (6005-T5) (6005A-T5, T61), ASTM B221

Primary Seal

- Dual Durometer 65 Shore A, 90 Shore A, ASTM D2240
- Available in 5 Standard colors

Standard Loading

- 500 lbs.

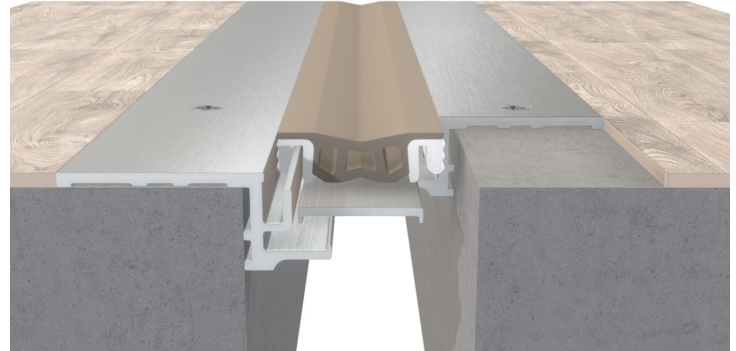

Note: 2" model includes an aluminum support plate for the gasket for added durability

MODEL	JOINT WIDTH	MINIMUM OPENING	MAXIMUM OPENING	EXPOSED SURFACE	BLOCKOUT WIDTH	BLOCKOUT HEIGHT
GFST-100	1.00" (25mm)	0.75" (19mm)	1.25" (32mm)	4.31" (109mm)	N/A	N/A
GFST-200	2.00" (51mm)	1.50" (38mm)	2.50" (64mm)	5.13" (130mm)	N/A	N/A
GFSTW-100	1.00" (25mm)	0.75" (19mm)	1.25" (32mm)	2.66" (68mm)	N/A	N/A
GFSTW-200	2.00" (51mm)	1.50" (38mm)	2.50" (64mm)	3.56" (90mm)	N/A	N/A

