

SCR-64MN CRASH RAIL

PLEASE READ

PLEASE READ THESE INSTRUCTIONS THOROUGHLY PRIOR TO BEGINNING THE SCR-64MN CRASH RAIL INSTALLATION!

THIS INSTRUCTION SHEET IS INTENDED TO PROVIDE A SPECIFIC GUIDE TO FOLLOW FOR THE INSTALLATION OF THIS SCR-64MN CRASH RAIL. CONTAINED WITHIN IS THE TECHNICAL INFORMATION AND INSTALLATION TECHNIQUES REQUIRED TO COMPLETE AN EFFICIENT, NEAT AND LONG-LASTING INSTALLATION.

INSPECT ALL MATERIALS FOR DAMAGE OR MISSING PARTS. IF YOU DISCOVER DAMAGED OR MISSING MATERIALS, IN THE USA PLEASE NOTIFY THE FACTORY AT (800) 233-8493, AND IN CANADA (888) 895-8955 FOR CUSTOMER SERVICE.

SCR-64MN CRASH RAIL MUST BE INSTALLED IN ACCORDANCE WITH THESE INSTRUCTIONS! FAILURE TO FOLLOW THESE INSTRUCTIONS MAY VOID ANY PRODUCT WARRANTIES AND RESULT IN AN UNSUCCESSFUL INSTALLATION. FOR SPECIFIC QUESTIONS REGARDING THE INSTALLATION OF THIS SCR-64MN CRASH RAIL PLEASE CALL THE FACTORY IN THE USA AT (800) 233-8493 OR EMAIL IWPTECHSUPPORT@C-SGROUP.COM. IN CANADA CALL (888) 895-8955.

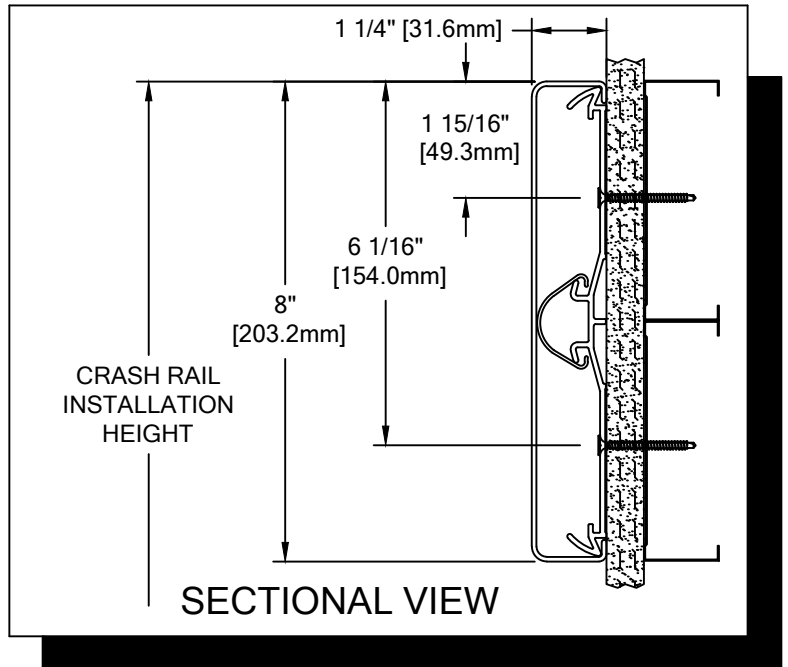

IMPORTANT NOTES

1. ALL LINEAL MATERIAL TO BE SUPPLIED IN STOCK LENGTHS. ALUMINUM AND ACROVYN IN LENGTHS UP TO 20'-0". THIS MATERIAL IS TO BE FIELD CUT USING QUALITY EQUIPMENT TO INSURE THAT ALL CUTS ARE SQUARE. WHEN CUTTING MATERIAL SECTIONS, C/S RECOMMENDS USING AN 80-100 TOOTH CARBIDE TIPPED SAW BLADE OR EQUIVALENT, TO MINIMIZE CHIPPING AND MAINTAIN JOINT ALIGNMENT.
2. RADIAL MATERIAL MAY BE SUPPLIED FACTORY FORMED OR IN STRAIGHT LENGTHS FOR FIELD FORMING. CONSULT FACTORY FOR OPTIONS.
3. ALL DIMENSIONS ARE TYPICAL.
4. FOR DRYWALL/PLASTER WALL CONSTRUCTION, IT IS RECOMMENDED FOR FASTENERS TO BE ENGAGED INTO METAL/WOOD STUDS TO MAINTAIN MAXIMUM PULLOUT STRENGTH. IF DURING INSTALLATION YOU ENCOUNTER SPECIAL WALL CONDITIONS THAT DO NOT ALLOW FOR DIRECT ATTACHMENT TO THE STUDS PLEASE CONSULT THE LOCAL AUTHORITY HAVING JURISDICTION.
5. AF-6 PLASTIC ANCHORS SHOULD SEAT FLUSH WITH GYPSUM WALL.
6. MATERIAL MUST REACH 65°F MIN. TO 75°F MAX. 24 HOURS PRIOR TO INSTALLATION. THIS IS ESSENTIAL TO MINIMIZE EXPANSION AND CONTRACTION OF MATERIAL.
7. THE DISTANCE BETWEEN AN ACROVYN SPLICE JOINT AND AN ALUMINUM RETAINER CLIP SHOULD BE STAGGERED 1" [25.4mm].
8. TANGENT POINTS ON FACTORY FORMED RADIAL MATERIAL WILL BE MARKED APPROXIMATELY AND SHOULD BE CUT TO SUIT FOR FIELD CONDITIONS.
9. THIS CRASH RAIL REQUIRES A MINIMUM OF 2 MOUNTING FASTENERS PER UNIT. THE MINIMUM END CAP-TO-END CAP CRASH RAIL LENGTH IS 7 7/8" [200mm].
10. FOR MORE INFORMATION ON SCR-64MN CRASH RAIL SEE OUR WEBSITE AT www.c-sgroup.com.

SCR-64MN CRASH RAIL

COMPONENTS & WALL FASTENERS

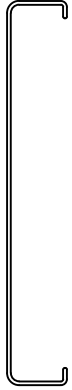

ACROVYN COVER
(24U042xxx)
ACROVYN WOODGRAINS
AND BRUSHED METALS COVER
(24U628xxx)



ALUMINUM RETAINER
(24A308000)



ACROVYN SPLICE COVER
(24F227108)



ACROVYN SPLICE
COVER RETAINER
(24F228000)



REGRIND BUMPER CUSHION
(24U820108H)

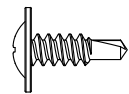

FASTENER #1
#8 X 1/2" PHILLIPS
WAFER HEAD TEK SCREW
(90H086002)

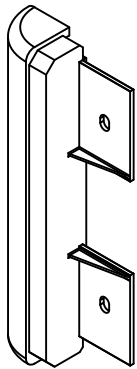

CRASH RAIL END CAP
(24I116xxx)
ACROVYN WOODGRAINS
AND BRUSHED METALS END CAP
(24I987xxx)

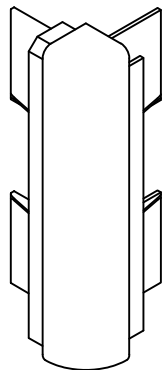

CRASH RAIL OUTSIDE
CORNER ASSEMBLY

WALL CONDITION	SPECIFIED FASTENER	DRILL DIAMETERS		C/S PART NUMBER
		WALL	RETAINER	
STEEL STUD/GYPSUM WALL	#10 X 1 1/2" PHILLIPS PAN HEAD SMS 1/4" FLAT WASHER SAE AF-6 PLASTIC ANCHOR	1/4"	9/32"	90H189002 90H007003 90H039004
CONCRETE/CONCRETE BLOCK	#10 X 1 1/2" PHILLIPS PAN HEAD SMS 1/4" FLAT WASHER SAE AF-6 PLASTIC ANCHOR	1/4"	9/32"	90H189002 90H007003 90H039004
WOOD STUD/GYPSUM WALL	#9 X 2 1/4" WAFER HD PH DRYWALL SCREW 1/4" FLAT WASHER SAE	N/A	N/A	90H421002 90H007003
20 GA. MIN. STEEL STUD AND 20 GA. MIN. STEEL STRAPPING / GYPSUM WALL CONSTRUCTION REQUIRED (TEK SCREWS)	#6 X 1 5/8" PHILLIPS BUGLE HEAD TEK SCREW	N/A	N/A	90H079002

SCR-64MN CRASH RAIL

LAYOUT VIEW

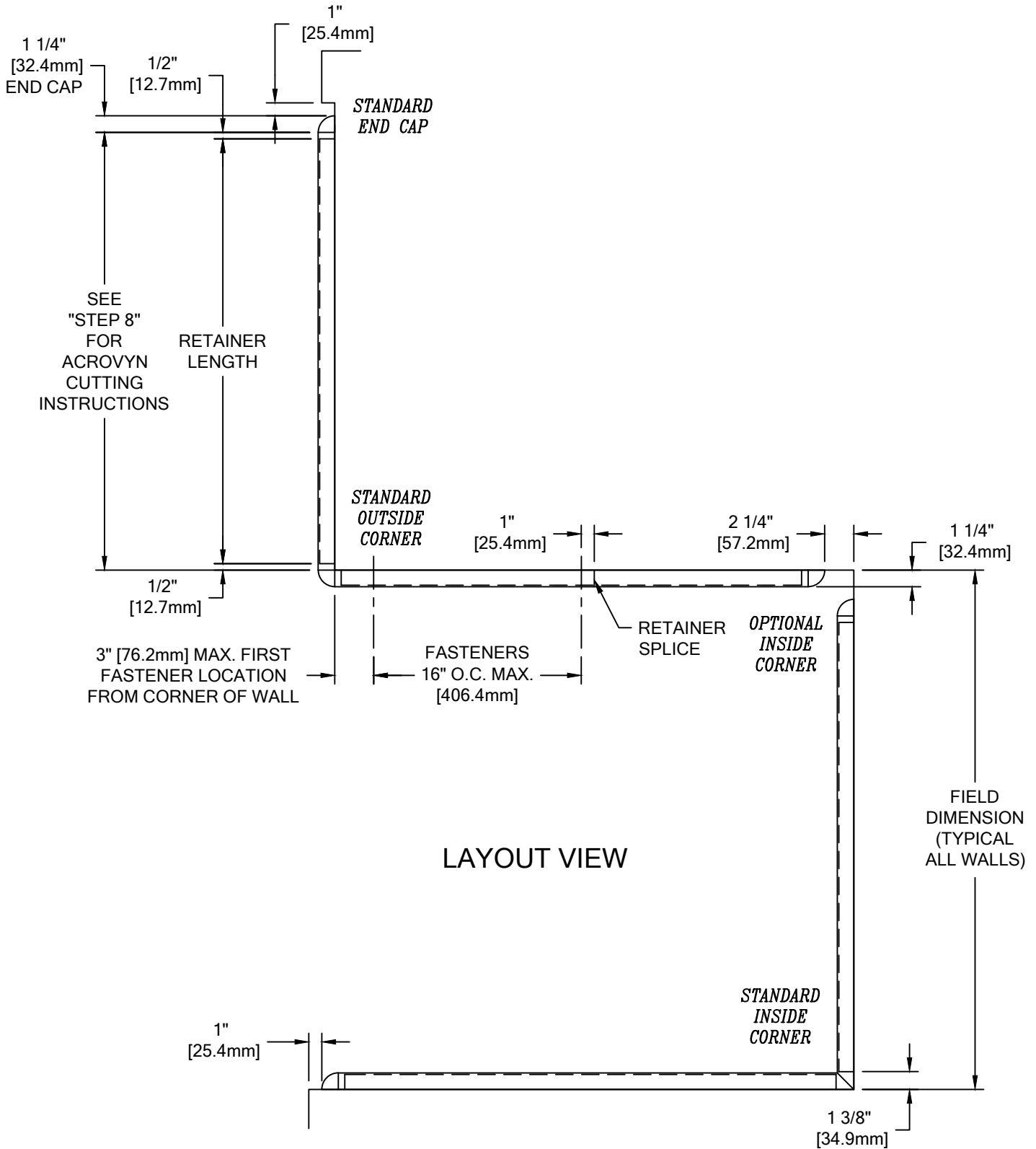

LAYOUT VIEW

SCR-64MN CRASH RAIL

TYPICAL ASSEMBLY

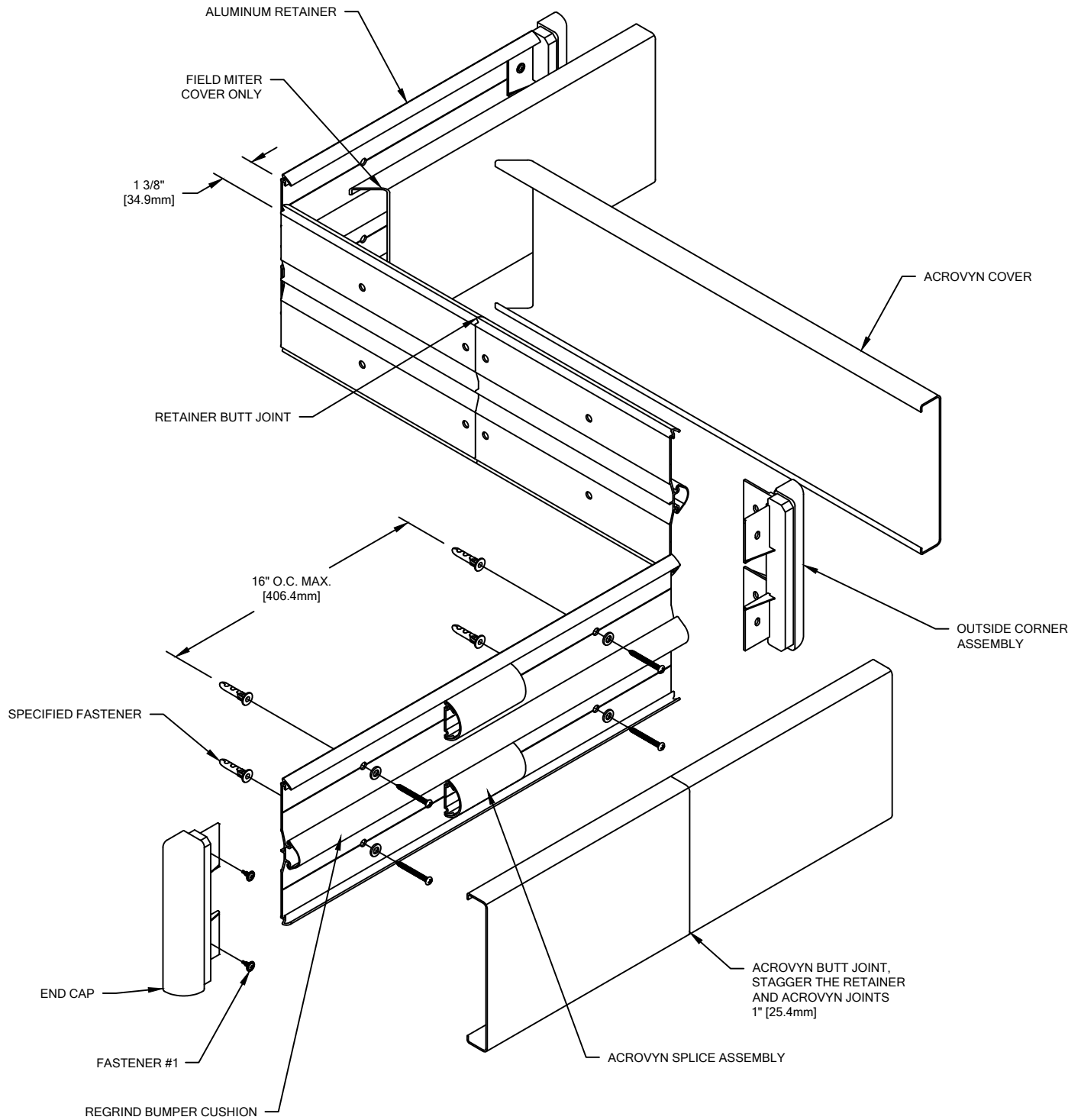

SCR-64MN CRASH RAIL

SPLICE COVER ASSEMBLY

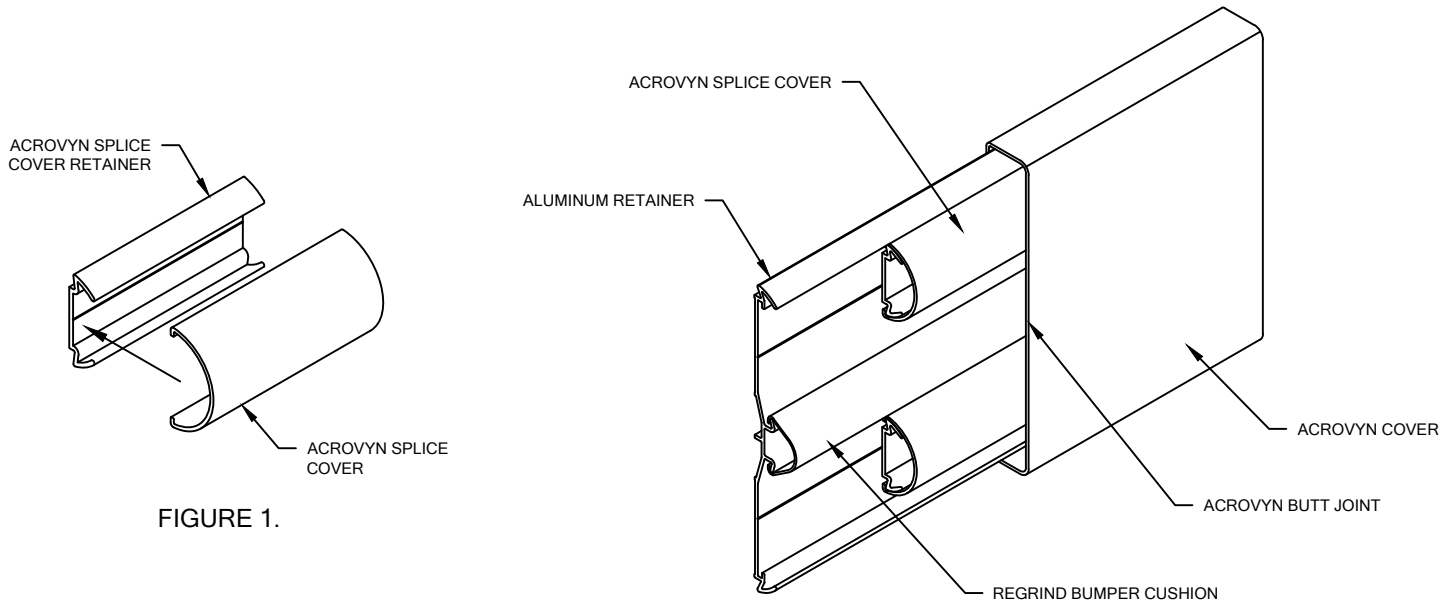

FIGURE 1.

NOTE: INSTALLATION OF LINEAL OR RADIAL SCR-64MN CRASH RAIL SHOULD BE DONE IN ACCORDANCE WITH THE FOLLOWING INSTRUCTIONS.

1. ESTABLISH CRASH RAIL HEIGHT ABOVE FINISH FLOOR. DEDUCT 1 15/16" [49.3mm] AND 6 1/16" [154.0mm] AND SNAP A CHALK LINE AT THAT HEIGHT. THIS MARKS THE LOCATION OF THE RETAINER FASTENERS. (SEE SECTIONAL VIEW)
2. CUT THE CONTINUOUS ALUMINUM RETAINER TO LENGTH, USING THE REQUIRED DEDUCTIONS AS NOTED (SEE LAYOUT VIEW). PRE-DRILL CLEARANCE HOLES IN THE ALUMINUM RETAINER 16" [406.4mm] O.C. AS REQUIRED. REFERENCE CHART ON PAGE 2 FOR CORRECT DRILL DIAMETERS.

NOTE: IT IS RECOMMENDED THAT THE ACROVYN COVERS AND ALUMINUM RETAINER BE CUT WITH AN 80-100 TOOTH CARBIDE TIPPED SAW BLADE OR EQUIVALENT.

3. USING THE RETAINER AS A TEMPLATE, MARK THE LOCATION OF THE FASTENERS. USE A LEVEL TO INSURE RETAINER IS PLUMB. DRILL CLEARANCE HOLES IN WALL SURFACE FOR MOUNTING HARDWARE. REFERENCE CHART ON PAGE 2 FOR CORRECT DRILL DIAMETERS.
4. ATTACH END CAPS/OUTSIDE CORNERS BY SLIDING THE END CAP/OUTSIDE CORNER ONTO THE END OF THE ALUMINUM RETAINER AND SECURING INTO POSITION USING TWO (2) #8 X 1/2" WAFER HEAD TEK SCREWS AT EACH END CAP AND FOUR (4) AT EACH OUTSIDE CORNER.

NOTE: TO AID IN LOCATING THE END CAPS CORRECTLY, CUT A 4" [101.6mm] SECTION OF COVER FROM SCRAP AND SNAP IT ON THE RETAINER. LOCATE THE CAP SO IT ALIGNS FLUSH WITH THE TOP AND BOTTOM OF THE COVER.

5. INSTALL EACH SECTION OF ASSEMBLED RETAINER, IN SUCCESSION, USING THE APPROPRIATE HARDWARE. USE A LEVEL TO INSURE RETAINER IS PLUMB.

NOTE: WHEN FIELD FORMING RADIUS CRASH RAIL, BE SURE TO APPLY NEEDED PRESSURE FROM FASTENER TO FASTENER.

6. CUT THE REGRIND BUMPER CUSHION TO LENGTH NOTING THE REQUIRED DEDUCTIONS (SEE LAYOUT VIEW) AND INSTALL ONTO ALUMINUM RETAINER.
7. ATTACH THE ACROVYN SPLICE COVER TO THE APPROPRIATE RETAINERS BY SNAPPING THEM INTO PLACE. REMOVE THE PROTECTIVE COVERING FROM THE FACTORY APPLIED ADHESIVE AND ATTACH THE ASSEMBLY TO THE RETAINER AT ALL ACROVYN SPLICE JOINTS.
8. CUT THE ACROVYN COVER TO THE PROPER LENGTH. THE COVER LENGTH IS DETERMINED BY MEASURING THE DISTANCE BETWEEN THE INSTALLED END CAPS AND/OR OUTSIDE CORNERS.

NOTE: IT IS RECOMMENDED THAT THE ACROVYN COVERS BE CUT SLIGHTLY LONGER (1/32" UP TO 5'-0", 1/16" OVER 5'-0") THAN THE MEASURED DISTANCE. THIS ADDITIONAL LENGTH WILL PROVIDE FOR A TIGHTER COVER-TO-END CAP FIT.

9. ALIGN THE TOP OF THE ACROVYN COVER WITH THE TOP OF THE ALUMINUM RETAINER AND SNAP THE COVER ONTO THE BOTTOM SECTION OF THE RETAINER.

NOTE: MANUFACTURER RECOMMENDS ALL PRINTED "PRODUCT IDENTIFICATION" ON THE REAR OF THE ACROVYN PROFILE SHALL BE ORIENTED IN THE SAME DIRECTION DURING INSTALLATION TO ENSURE PROPER ALIGNMENT AT SPLICE BUTT JOINTS.

09/26/2025