

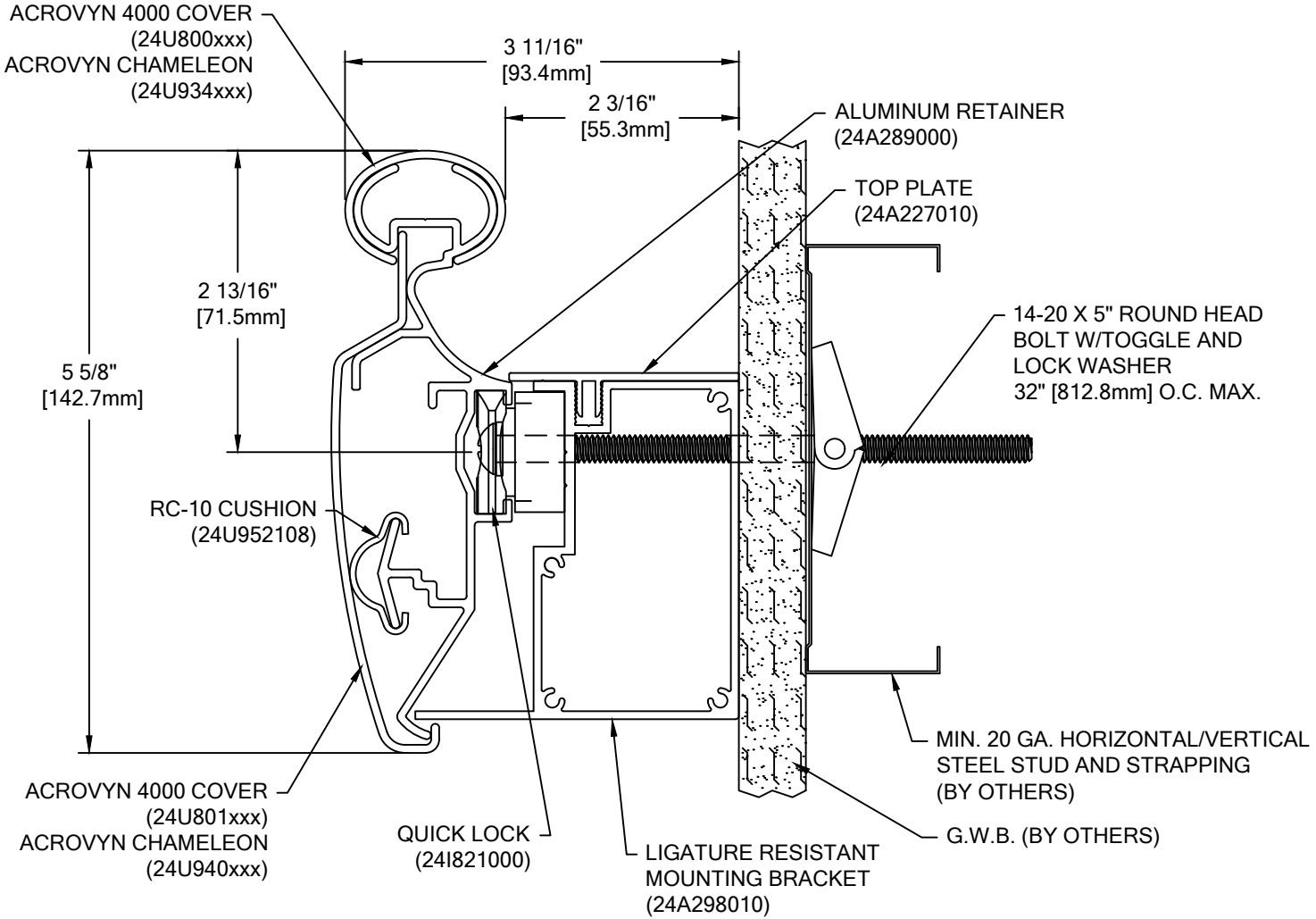

COLOR:
 TOP RAIL: _____
 BOTTOM RAIL: _____
 *MOUNTING BRACKET: _____
 COLOR TO BE SELECTED FROM ONE OF CS STANDARD COLORS.
 *MOUNTING BRACKET SUPPLIED IN STANDARD MILL FINISH. OPTIONAL CLEAR ANODIZED AND POWDER COAT FINISH AVAILABLE. PLEASE ADVISE POWDER COAT FINISH IF REQUIRED.
 *OPTIONAL VERTICAL ACCENT AVAILABLE. SEE CS CATALOG FOR COLORS.

TOTAL L/F REQ'D	LEFT END CAPS	RIGHT END CAPS	O.S.C. REQ'D



HRB-20CMN ACROVYN 4000 INTERNATIONAL OFFSET

WALL CONDITION	SPECIFIED FASTENER	DRILL DIAMETERS		CS PART NUMBER
		WALL	RETAINER	
STEEL STUD/GYPSUM WALL	1/4-20 X 5\"/>			
CONCRETE/CONCRETE BLOCK	#14 X 5\"/>			
WOOD STUD/GYPSUM WALL	#14 X 5\"/>			

 Hughesville, PA 800.233.8493 570.546.5941 Mississauga, ON 888.895.8955 905.274.3611 www.c-sgroup.com © Copyright 2016 Construction Specialties, Inc.	PROJECT:	REVISION:
	JOB NO.:	F&F:
	CUSTOMER:	
	REP:	DATE:
	DRAWN BY:	SHEET NO: