

Zip Block™ MODEL ZB 100 - 400 INSTALLATION INSTRUCTIONS

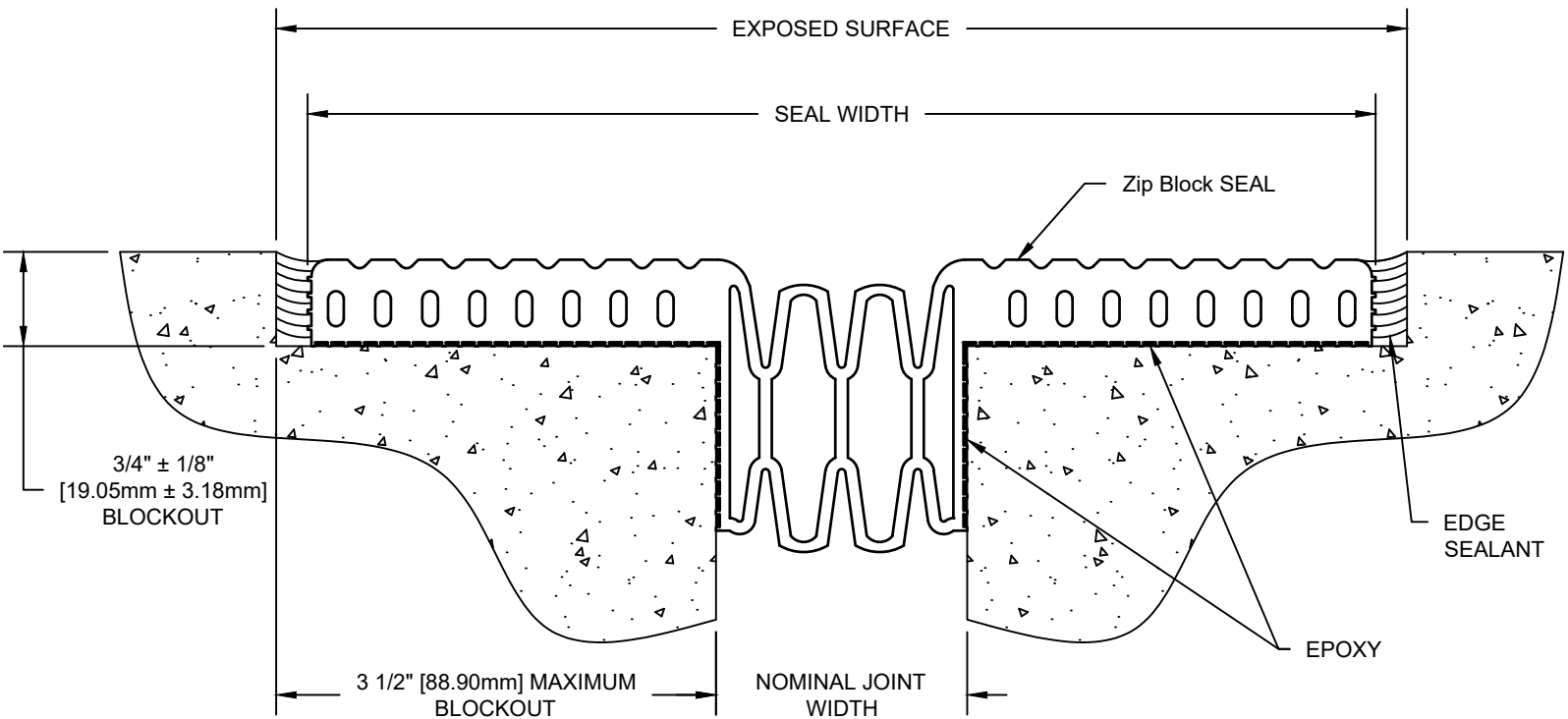

	ZB-100	ZB-200	ZB-300	ZB-400
EXPOSED SURFACE	8" [203.20mm]	9" [228.60mm]	10" [254.00mm]	11" [279.40mm]
SEAL WIDTH	7½" [190.50mm]	8½" [215.90mm]	9½" [241.30mm]	10½" [266.70mm]
NOMINAL JOINT WIDTH	1" [25.40mm]	2" [50.80mm]	3" [76.20mm]	4" [101.60mm]

IMPORTANT INFORMATION

Prior to the commencement of installation, all materials **MUST** be inspected for damage. Any damage must be reported to CONSTRUCTION SPECIALTIES, INC., as soon as possible, so that replacement materials may be furnished without delay.

All work must be completed as per Architect's Approved "Shop Drawings", and in accordance with these Installation Instructions. When installation is complete, all materials must be protected from damage until the Architect's FINAL INSPECTION.

All materials should be arranged in the order that they are to be installed. All hardware required for each portion of the work should be placed with the appropriate materials.

Please review all Approved Shop Drawings and this document to familiarize yourself with all the details and components of this assembly.

IMPORTANT:

READ THROUGH ALL INSTRUCTIONS PRIOR TO STARTING INSTALLATION

7/17/2023



Construction Specialties®

www.c-sgroup.com

6696 Route 405 Highway, Muncy, PA 17756
Phone: (800) 233-8493 / Fax: (570) 546-8022

This document is the property of Construction Specialties, Inc. and contains PROPRIETARY INFORMATION that is not to be disclosed to third parties and is not to be used without approval in writing from Construction Specialties, Inc.

© Copyright 2016 Construction Specialties, Inc.

GENERAL NOTES:

Product Identification Table	
CS Call Out:	Product Name:
Epoxy	Pro Poxy 300
Edge Sealant (Horizontal Joints)	Vulkem 45SSL (Horizontal Joints)
Edge Sealant (Vertical Joints)	NovaLink 35 (Vertical Joints)
Splice Sealant	Loctite 5900
Instant Adhesive	3M Scotch Weld

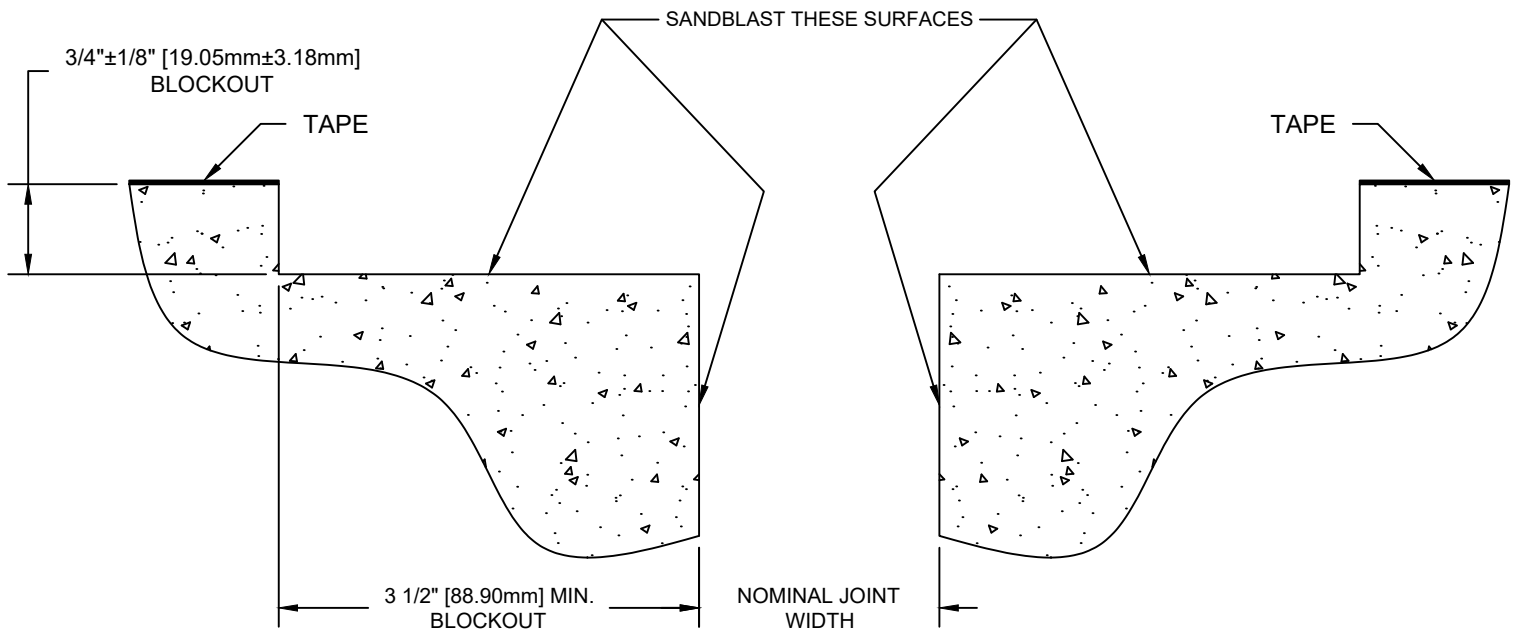

1. Before beginning installation of the ZB seal, review the layouts for the various runs of seal as detailed on the approved Construction Specialties shop drawings.
2. The "ZB" series compression seals must be securely mounted to structurally sound concrete that has cured for at least 7 days. Repair all damage to the blockouts before beginning installation.
3. The blockouts in which the ZB seal is to be mounted must be flat, level and parallel. The base of the blockout must be flat (along the length of the joint) to within $\pm 1/8"$ [3.18mm] and level (across the joint) to within $\pm 1/8"$ [3.18mm].
4. The blockout width shown on the Construction Specialties shop drawings is a minimum width dimension. The blockout may be made up to $1/4"$ [6.35mm] wider to allow for greater installation tolerance.
5. The blockout surfaces must be sandblasted to expose new concrete and remove all form release agents and other foreign materials.
6. The surface of the blockouts must be clean and free from any loose dust, dirt, debris and oils that would affect the installation of the seal, or adhesion of the epoxy.
7. Refer to the Construction Specialties Expansion Joint Tech Manual for proper joint width at time of seal installation.
8. All splices and transitions must be cut square and smooth to ensure a good seal.
9. When cutting the seal for any transitions, the cell must be compressed to the installed joint size (nominal size) to match up properly when installed.

STEP 1

PREPARE SEAL

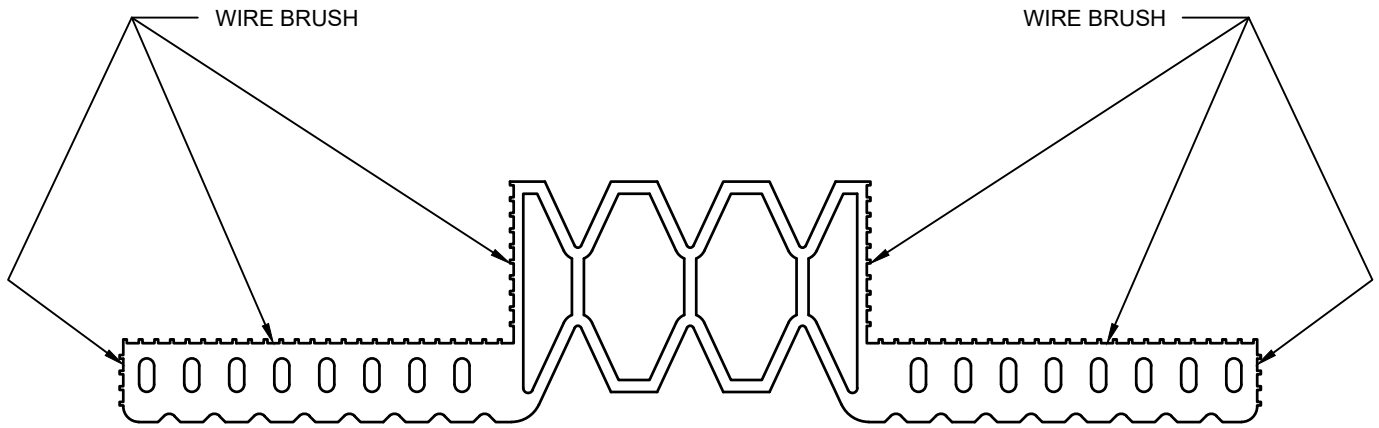

Step 1:

- 1.1) Unroll each length of compression seal and lay each one upside-down on a flat surface.
- 1.2) Wire brush the bottom and sides of the wings and sides of the compression area thoroughly using a drill or grinder with a wire wheel mounted in the chuck. All of the wire brushed areas should have a dull black appearance when finished. There should be no gloss or white residue left on these surfaces. The epoxy may not bond properly if the seal is not thoroughly wire brushed.
- 1.3) Clean the seal thoroughly using compressed air to remove any loose rubber particles left behind from the wire brush.

STEP 2

BEGIN INSTALLATION

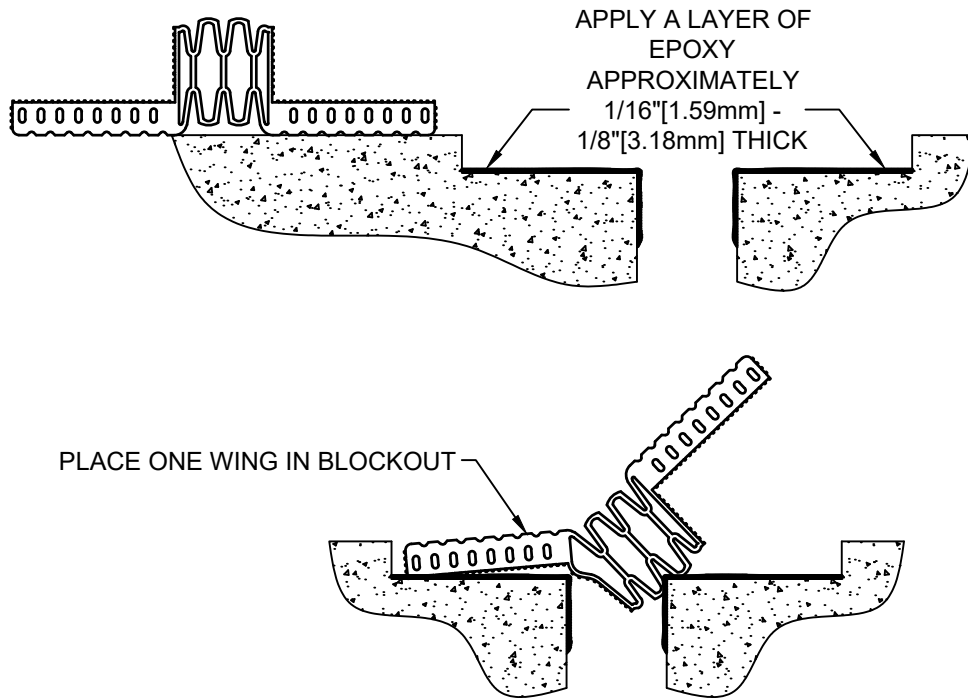

***IMPORTANT NOTE:** Do not use Epoxy or install this seal if either the substrate temperature or air temperature will drop below 40°F [5°C] during the installation or cure time of 8 hours.

Step 2:

- 2.1) Place each length of seal upside-down next to the blockout area where it is to be installed. This will allow the seal some time to flatten before it is bonded in place.
- 2.2) Check to ensure that the concrete blockouts are free from loose dirt, debris and oils. It is critical that the blockouts are clean to allow the Epoxy to achieve the proper bond.
- 2.3) Mix the Construction Specialties supplied, 2 component Epoxy. Measure equal amounts of Part A and Part B by volume. Pour both Part A and Part B into a container and mix thoroughly for three minutes until a uniform gray color is achieved. Do not mix in direct sunlight as this will decrease the work life of the Epoxy. Only mix the amount of Epoxy that can be used within its gel time (see chart for gel time based on temperature).
- 2.4) Apply the Epoxy by loading it into a bulk gun and ejecting it into the blockout area. Spread the Epoxy with a trowel until it is approximately 1/16"[1.59mm] - 1/8"[3.18mm] thick. Apply Epoxy approximately 1 1/2"[38.1mm] down the vertical face of the joint. The Epoxy must be applied quickly to allow time for the seal to be installed before it begins to gel. Once the Epoxy has begun to gel or get hot, a proper bond will not be achieved.

APPROXIMATE WORK LIFE OF EPOXY	
TEMPERATURE	WORK LIFE
50°F [10°C]	35 MINUTES
70°F [21.11°C]	25 MINUTES
85°F [29.44°C]	20 MINUTES

- 2.5) Place the first section of seal into the blockout area. Place the wing on one side of the seal into the blockout.
- 2.6) Ensure that the seal is in the correct position along the length of the joint.

STEP 3

INSTALL SEAL IN JOINT

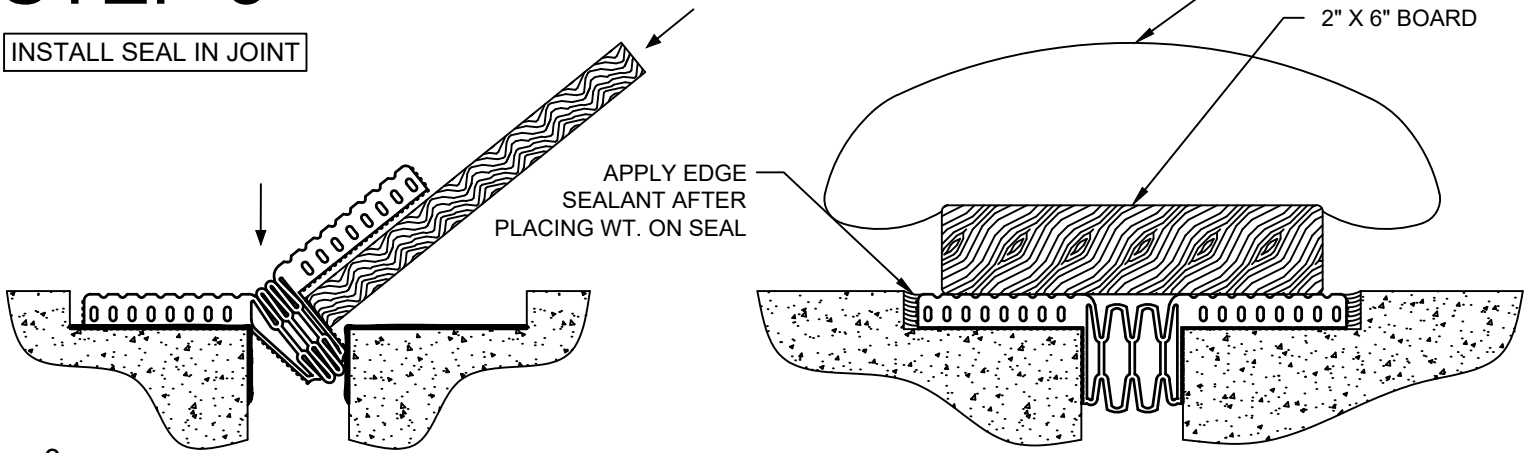

Step 3:

- 3.1) Starting at one end of the seal, lift the wing that was not previously seated in the blockout and push inward on the compression seal using a shaft (3/4" [19.05mm] plywood, metal bar stock, etc.). As you push inward on the compression seal every few inches, have someone follow behind you walking on the seal to seat it into place.
- 3.2) Place 2" [50.80mm] X 6" [152.40mm] boards on the compression seal the entire length of the seal.
- 3.3) Place Sand Bags, or something of similar weight, every couple feet on top of the boards. This will force the seal to seat into the epoxy during the cure cycle. Note: This is especially important at splice locations, be sure the ends of the seal are flat and lined up.
- 3.4) Allow the weights and boards to remain on the seal for approximately 8 hours.
- 3.5) Apply the Construction Specialties supplied Edge Sealant to the edge of the seal. This step can be performed as each section of seal is placed, or after the entire run of seal has been installed, as outlined in Step 12.

Note: It is recommended to apply the Edge Sealant after each section of seal is placed to prevent dirt and debris from entering the gap at the seal edge.

STEP 4

PREPARE SEAL FOR SPLICES

*NOTE: SPLICE KITS SOLD SEPARATELY

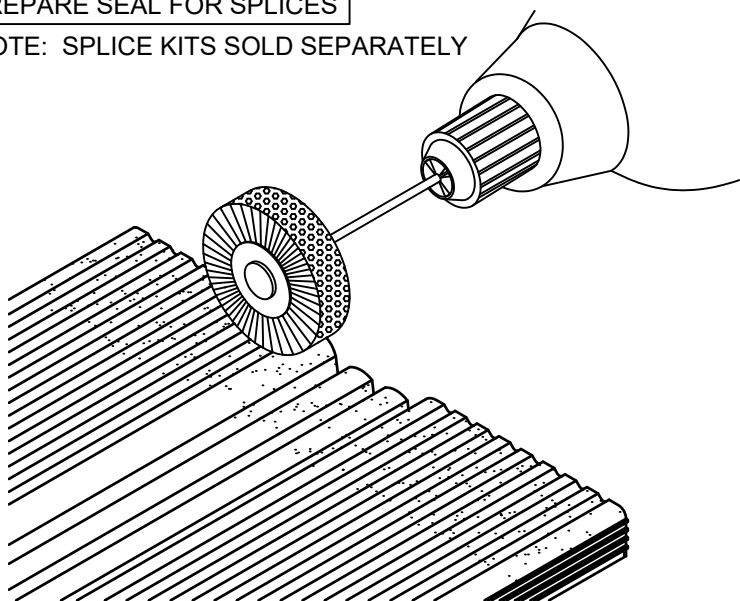

Step 4.1

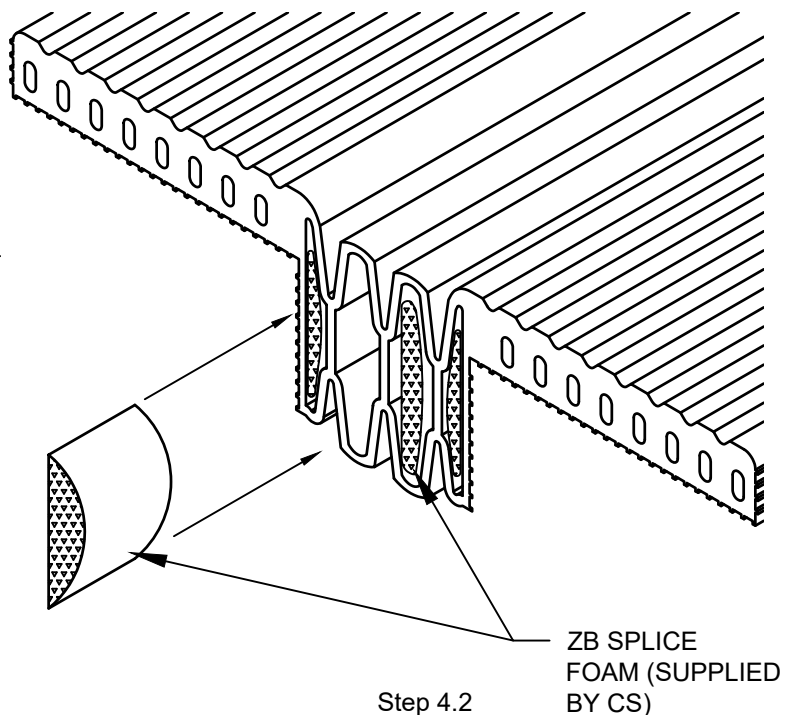

Step 4.2

Step 4:

- 4.1) Before applying the Splice Sealant use a wire brush (see detail above) to create a rough surface on the seal approx. 2" [50.80mm] from the edge. Be sure to rough up the sides and bottoms of the V-grooves as much as possible. This will ensure that the seal surface and Splice Sealant have a good bond. Wire brushed areas should have a dull black appearance when finished. Clean the seal thoroughly using compressed air to remove any loose rubber particles left behind from the wire brush.
- 4.2) Install CS supplied open cell ZB Splice Foam in ends of ZB cell openings at this point.

STEP 5

SPLICES

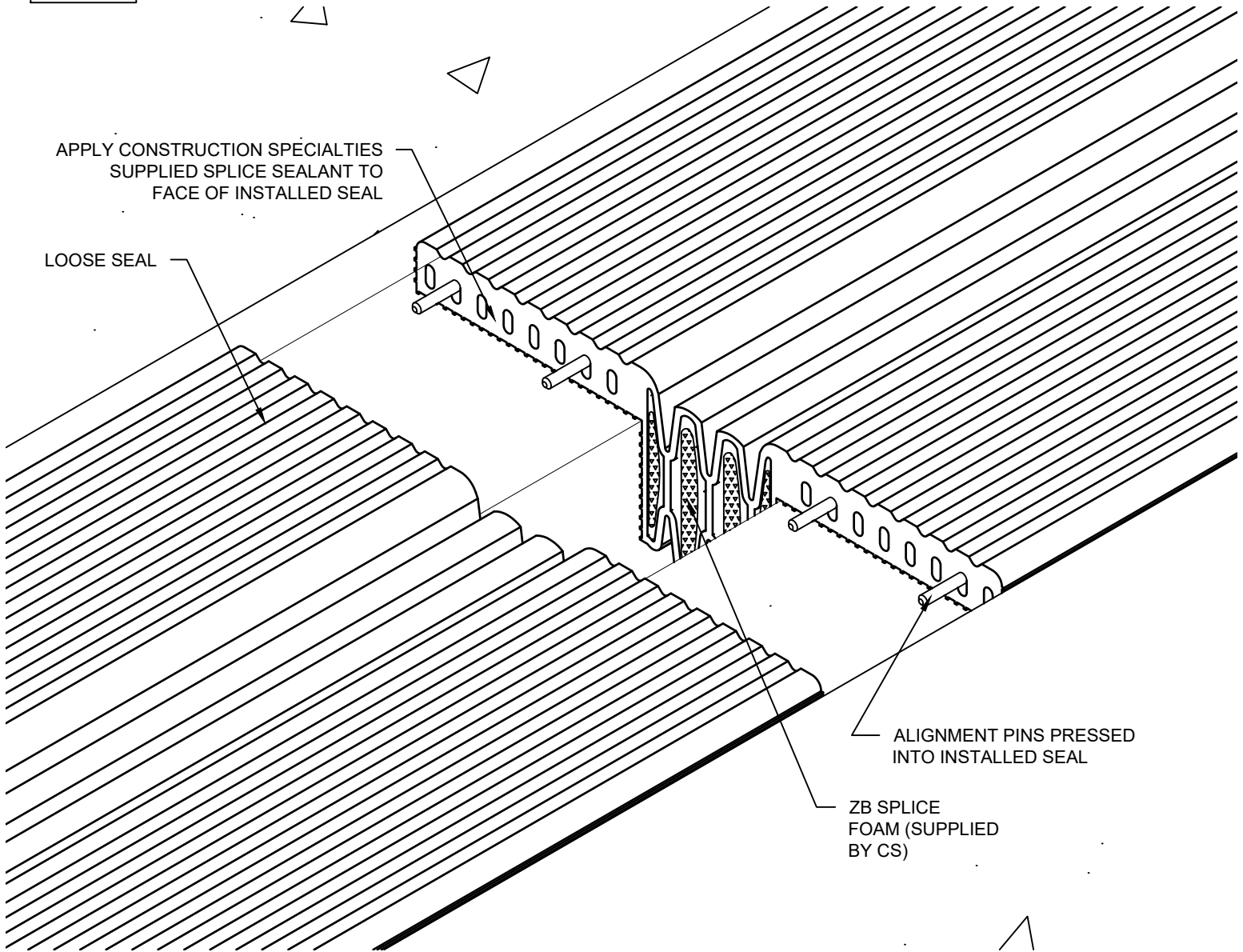

Step 5:

- 5.1) Ensure that the ends of the next seal to be installed are cut square and clean.
- 5.2) Apply the Construction Specialties supplied instant adhesive to the grooved end of alignment pins, and place in the oval slot of the installed seal, approximately 1/2 of its length. Repeat this step until you have placed 4 alignment pins as shown in the figure above.
- 5.3) Apply the Construction Specialties supplied Splice Sealant to the end of the previously installed section of seal.
- 5.4) Follow Step 2 to mix and apply the epoxy to the blockout area of the next section of joint.
- 5.5) Place the end of the next section of seal in the blockout and press the first 5-6 inches [127mm-152.4mm] of the seal into the joint to align the alignment pins with the end of the previously installed section.
- 5.6) Slide the seal against the end of the installed section so that the alignment pins slide into the corresponding cells. Ensure that there is not a gap between the ends of the seals.
- 5.7) Place remaining length of seal in the blockout and install according to Steps 2 and 3.

STEP 5 (Cont.)

SPLICES

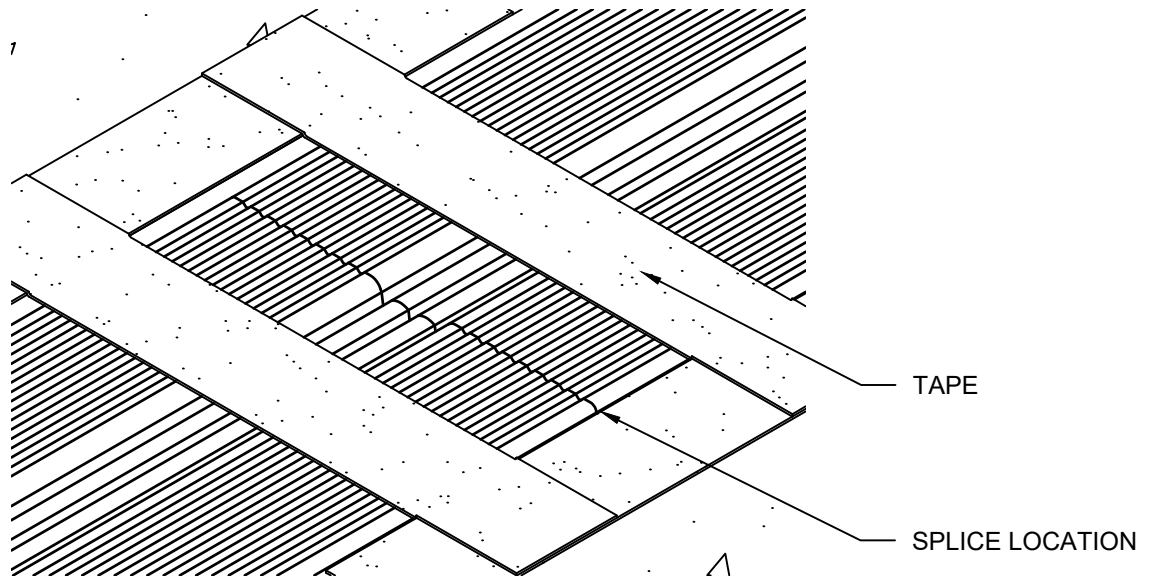

Step 5.8

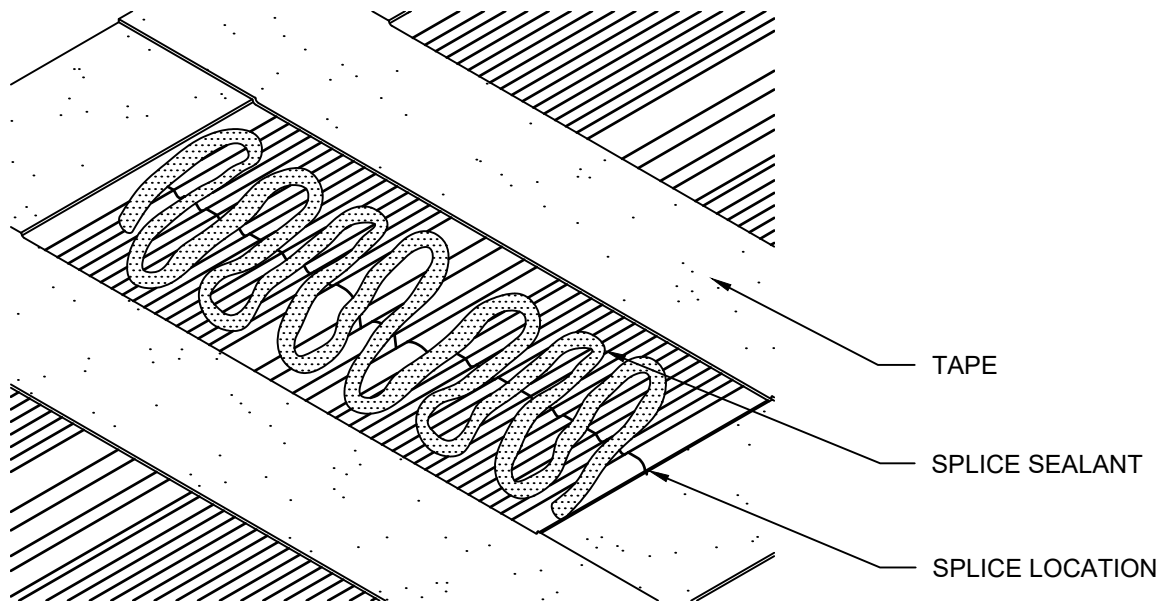

Step 5.9

- 5.8) Apply 2" [50.80mm] wide Tape along the top surface of the seal approx. 2" [50.80mm] away from joint splice. The Tape should be applied on both sides of the joint splice and both sides of the joint.
- 5.9) Apply the Construction Specialties supplied Splice Sealant into the base of the V's, filling the V's and any other voids.
- 5.10) Apply the Construction Specialties supplied Splice Sealant across the seal in a zigzag pattern crossing the splice. Apply sufficient amounts of Splice Sealant to create, when smoothed out, an approx. thickness of 1/8" [3.18mm] to 3/16" [4.76mm].

STEP 5 (Cont.)

SPLICES

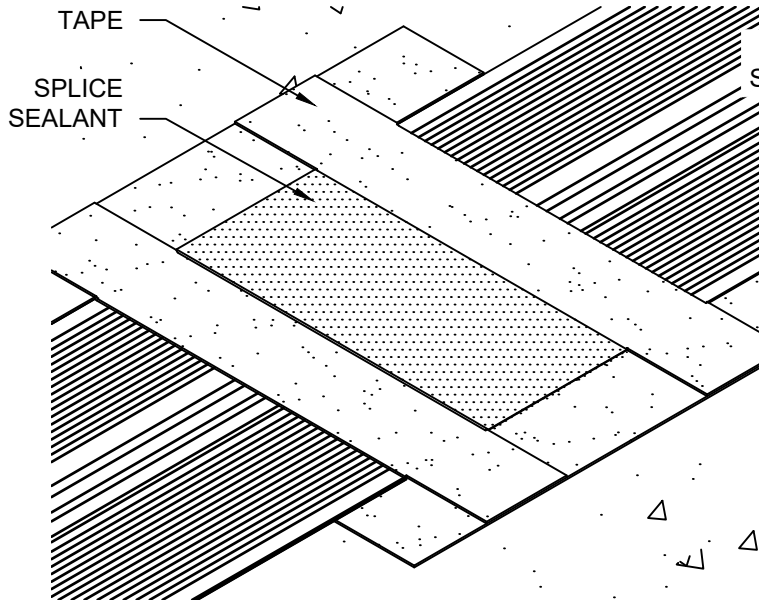

Step 5.11

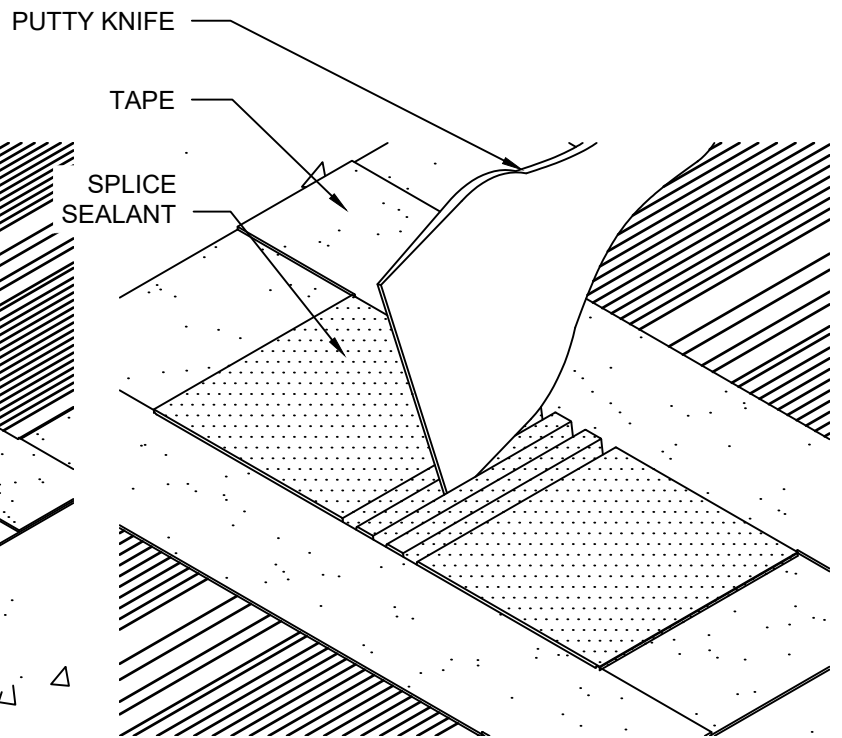

Step 5.12

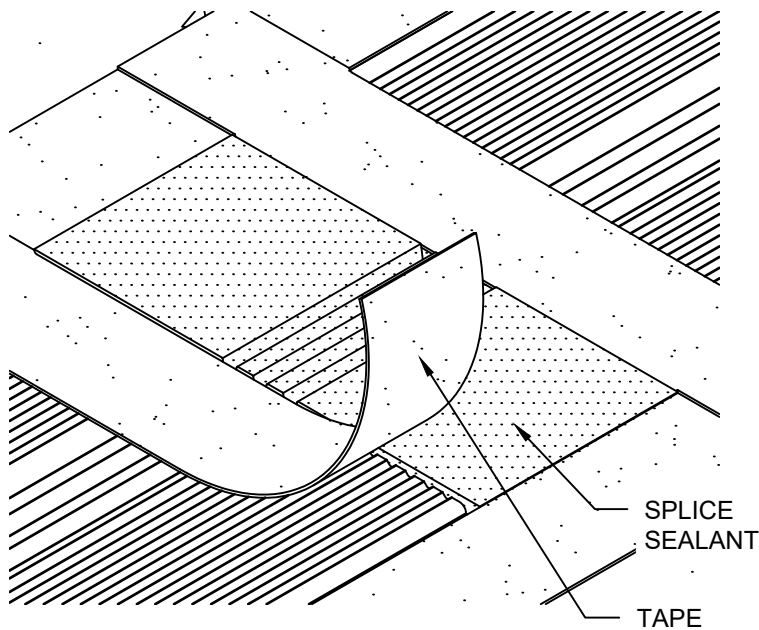

Step 5.12

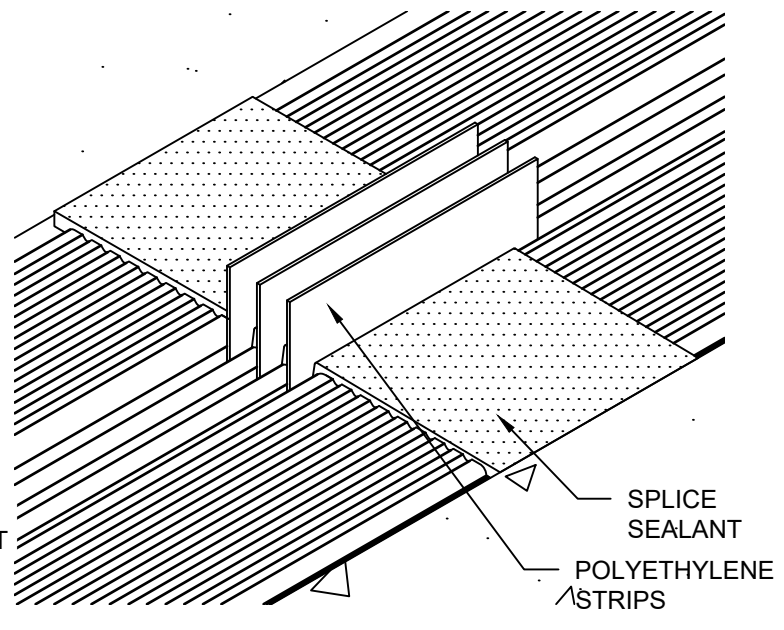

Step 5.13

- 5.11) Use a Putty Knife to smooth out the Construction Specialties supplied Splice Sealant evenly over the entire width of the seal.
- 5.12) Use a clean Putty Knife to separate the Splice Sealant between the V's. This will allow the seal to move without tearing the Splice Sealant apart. Be careful not to separate too deep into the V's. Splice Sealant should be approx. 1/8" [50.80mm] on bottom and sides of the V's. After separating the V's, make sure that you smooth out the edges of the Splice Sealant and remove the tape.
- 5.13) Place the Construction Specialties supplied pieces of 2"[50.8"] x 6"[152.4mm] polyethylene strips into the V's to prevent them from sticking together during cure time.
- 5.14) Allow the Splice Sealant to cure for 24-48 hours (depending on temperature) keeping all vehicles away from the splice and minimizing the amount of movement of the seal.

STEP 6

ANGLED INTERSECTION

MITER CUT SEAL

APPLY CONSTRUCTION SPECIALTIES
SUPPLIED SPLICE SEALANT TO CUT
SURFACES OF SEAL

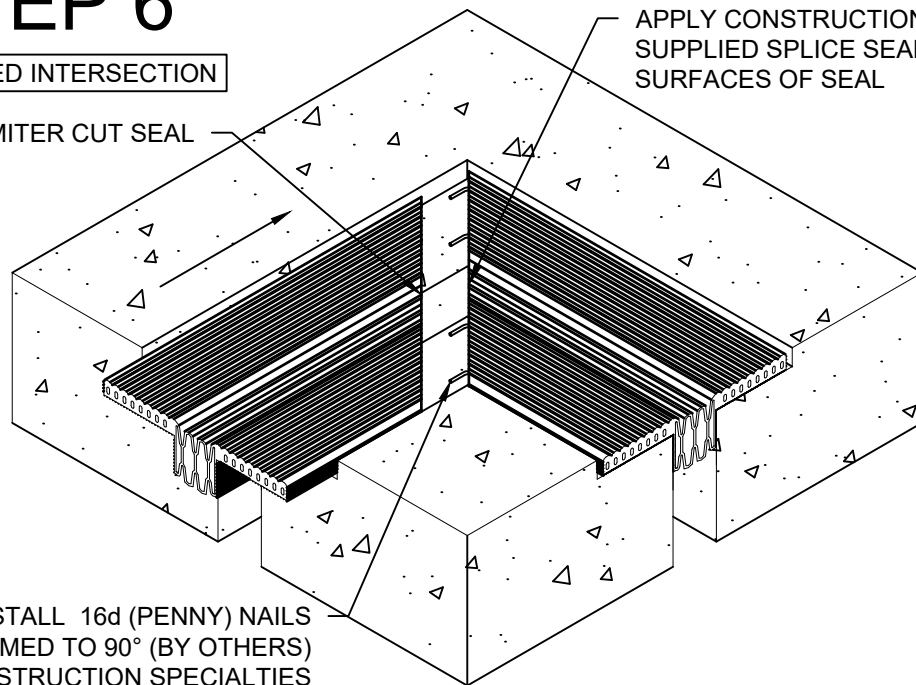

INSTALL 16d (PENNY) NAILS
FORMED TO 90° (BY OTHERS)
W/ CONSTRUCTION SPECIALTIES
SUPPLIED INSTANT ADHESIVE

CONSTRUCTION SPECIALTIES
SUPPLIED SPLICE SEALANT

POLYETHYLENE STRIPS

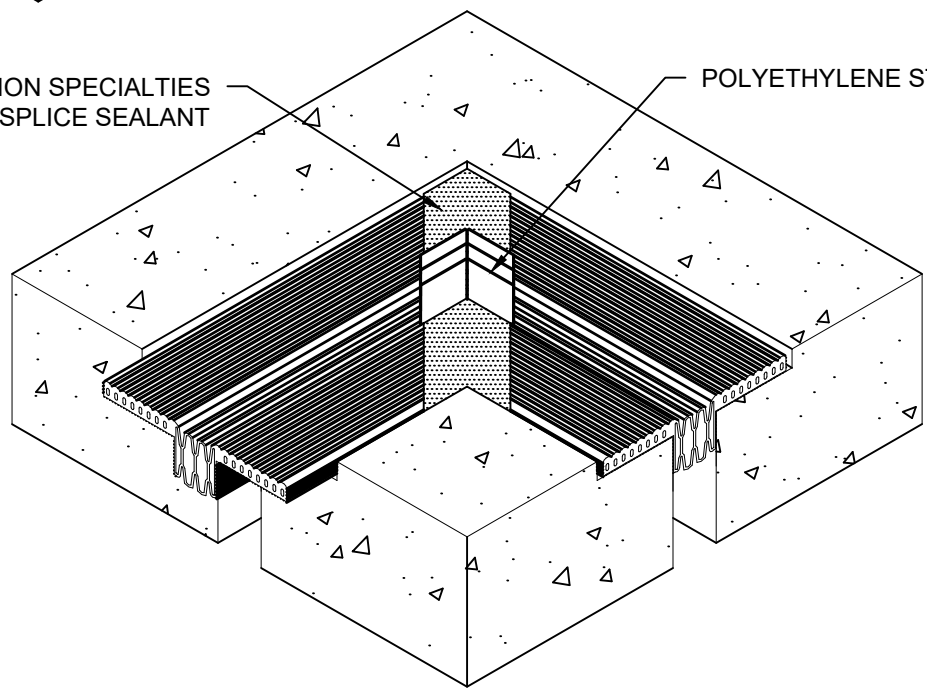

Step 6:

- 6.1) Miter the ends of the seals to the proper angle while compressed to the proper joint width.
- 6.2) Install the first section of seal according to Steps 1 through 5. Ensure that the miter cut end is at the proper location.
- 6.3) Install the 16d (PENNY) 90° formed nails with the Construction Specialties supplied instant adhesive in the end of the installed seal.
- 6.4) Apply the Construction Specialties supplied Splice Sealant to the cut end of the installed seal.
- 6.5) Follow Step 2 to mix and apply the Epoxy to the blockout area of the next section of joint.
- 6.6) Place the end of the next section of seal in the blockout and press the first 5-6 inches [127.00mm-152.40mm] of the seal into the joint to align with the alignment pins in the previously installed section.
- 6.7) Slide the seal against the end of the installed section so that the alignment pins slide into the corresponding cells. Ensure that there is not a gap between the ends of the seals.
- 6.8) Place the remaining length of seal in the blockout and install according to Steps 2 and 3.
- 6.9) Apply more Construction Specialties supplied Splice Sealant over the top of the splice in accordance with Step 5.

STEP 7

T-INTERSECTION

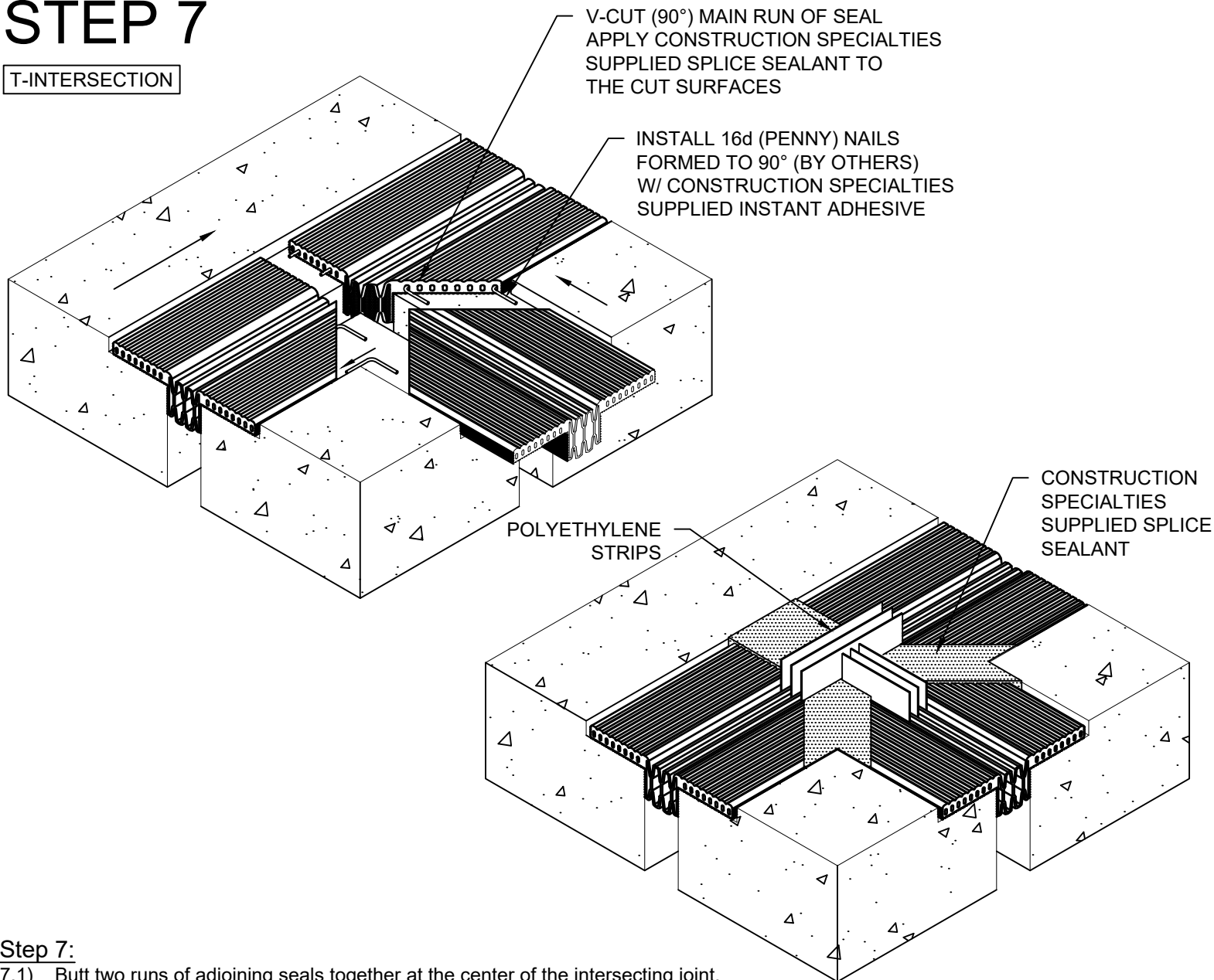

Step 7:

- 7.1) Butt two runs of adjoining seals together at the center of the intersecting joint.
- 7.2) Make a 45° cut through half the adjoining seals while compressed to the proper joint width as shown above.
- 7.3) Apply Construction Specialties supplied Splice Sealant to cut ends of the seals.
- 7.4) Slide the seal against the previously installed seal so that the alignment pins slide into the corresponding cells. Ensure that there is not a gap between the seals.
- 7.5) V-cut the end of the mating seal so that both seals will fit together properly.
- 7.6) Install the 16d (PENNY) 90° formed nails with the Construction Specialties supplied instant adhesive in the end of the installed seal.
- 7.7) Apply the Construction Specialties supplied Splice Sealant to the cut end of the installed seal.
- 7.8) Follow Step 2 to mix and apply the Epoxy to the blockout area of the next section of joint.
- 7.9) Place the end of the next section of seal in the blockout and press the first 5-6 inches [127.00mm-152.40mm] of the seal into the joint to align with the 16d (PENNY) 90° formed nails in the previously installed section.
- 7.10) Slide the seal against the V-cut of the installed section so that the 16d (PENNY) 90° formed nails slide into the corresponding cells. Ensure that there is not a gap between the seals.
- 7.11) Place the remaining length of seal in the blockout and install according to Steps 2 and 3.
- 7.12) Apply more Construction Specialties supplied Splice Sealant over the top of the splice in accordance with Step 5.

STEP 8

CROSS INTERSECTION

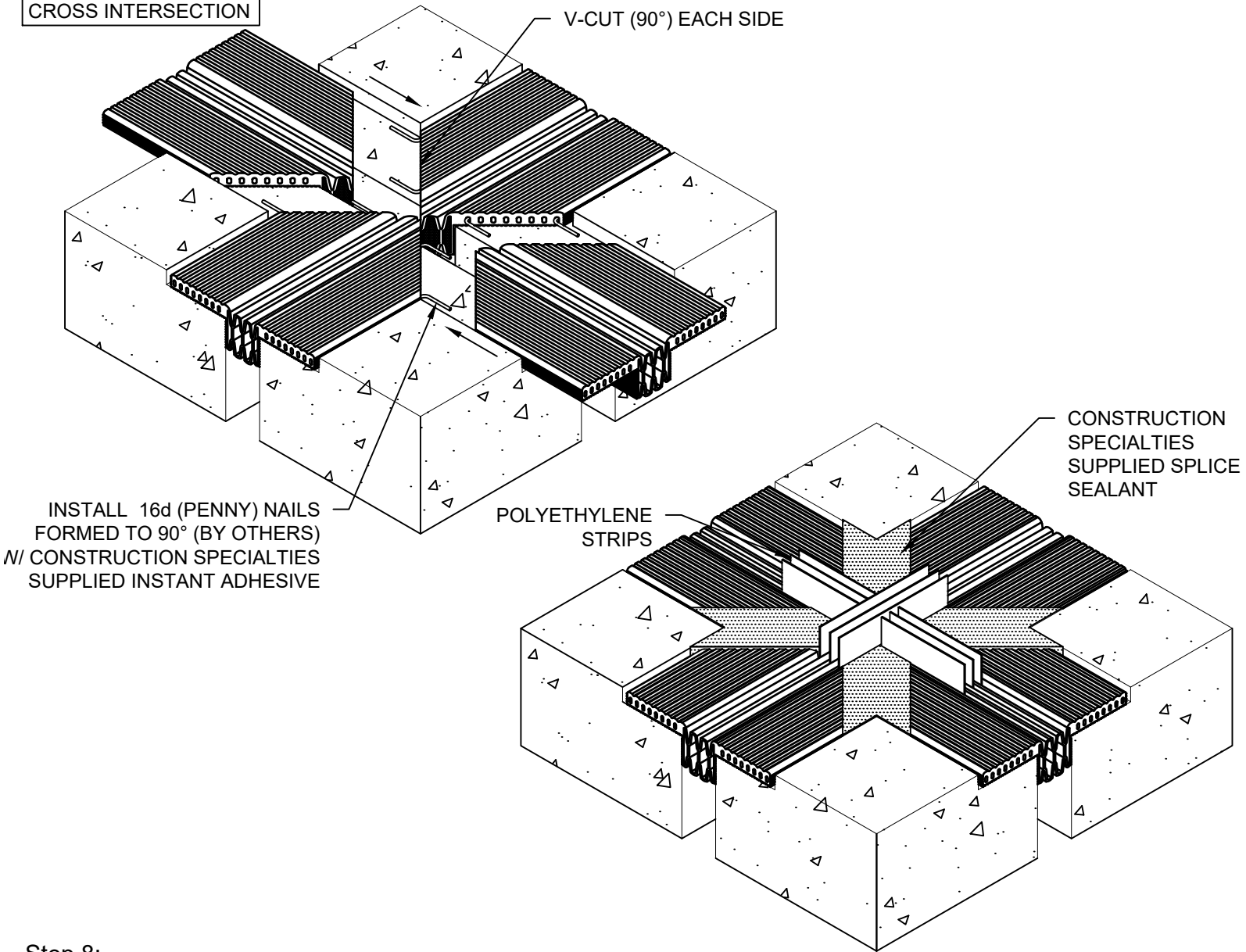

Step 8:

- 8.1) V-cut each side of the main run of seal at the joint intersection while compressed to proper joint width as shown above.
- 8.2) V-cut the ends of the mating sections of seal to allow them to fit properly with the main run.
- 8.3) Install the 16d (PENNY) 90° formed nails with the Construction Specialties supplied instant adhesive in the V-cuts of the main run of seal.
- 8.4) Apply the Construction Specialties supplied Splice Sealant to the cut end of the installed seal.
- 8.5) Mix the Epoxy and apply it to the blockout areas as outlined in Step 2.
- 8.6) Place the end of the next section of seal in the blockout and press the first 5-6 inches [127.00mm-152.40mm] of the seal into the joint to align with the 16d (PENNY) 90° formed nails in the previously installed section.
- 8.7) Slide the seal against the end of the installed section so that the 16d (PENNY) 90° formed nails slide into the corresponding cells. Ensure that there is not a gap between the ends of the seals.
- 8.8) Place the remaining length of seal in the blockout and install according to Steps 2 and 3.
- 8.9) Repeat the above steps to install the opposite side of the cross intersection.
- 8.10) Apply more Construction Specialties supplied Splice Sealant over the top of the splice in accordance with Step 5.

STEP 9

VERTICAL TRANSITION

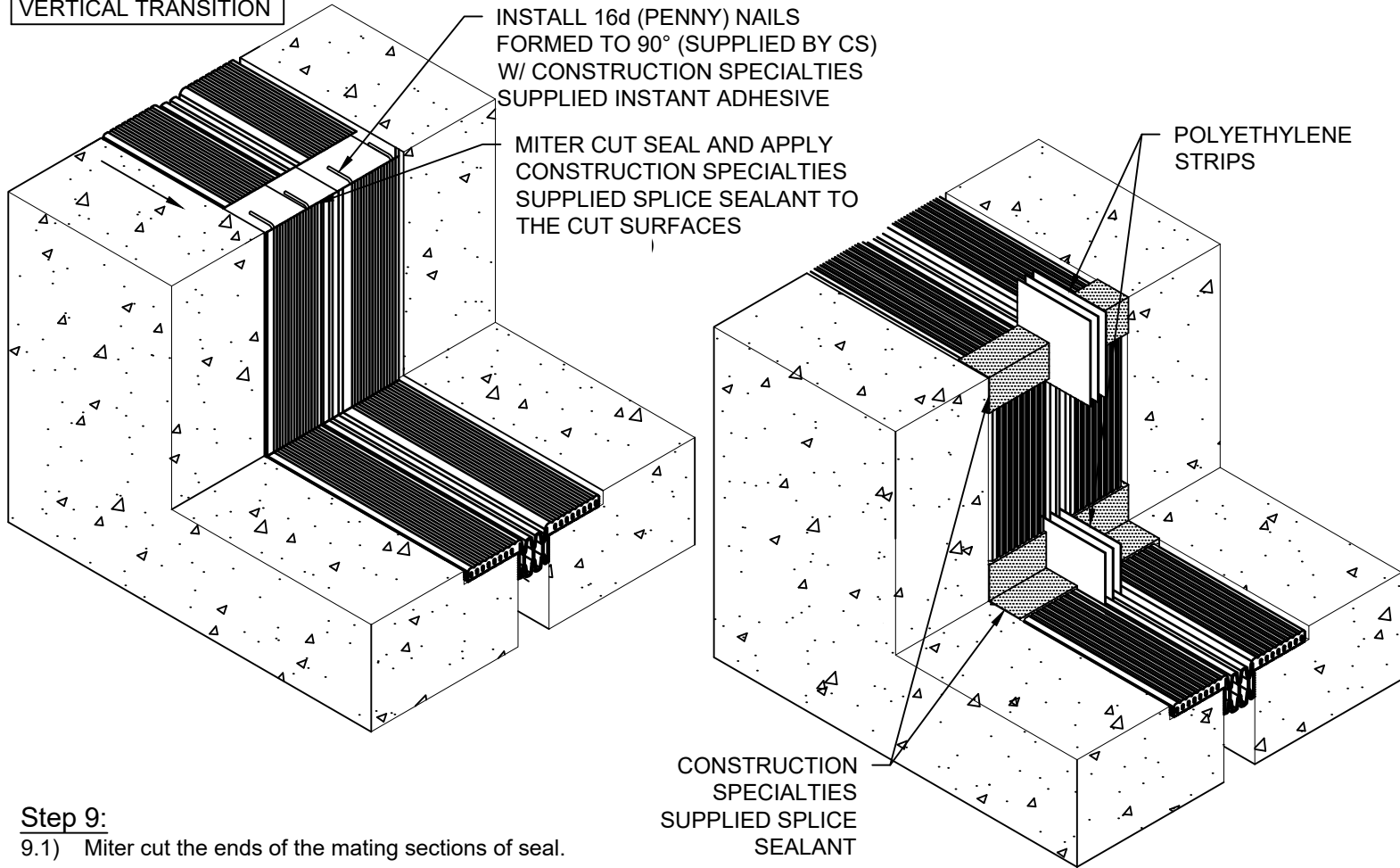

Step 9:

- 9.1) Miter cut the ends of the mating sections of seal.
- 9.2) Install 16d (PENNY) 90° formed nails in the bottom horizontal section of seal using the Construction Specialties supplied instant adhesive.
- 9.3) Install the bottom horizontal run of seal following Steps 1 through 4. Ensure that the mitered end of the seal is located properly in the blockout.
- 9.4) Apply the Construction Specialties supplied Splice Sealant to the cut end of the seal.
- 9.5) Mix the Epoxy and apply it to the vertical blockout areas as outlined in Step 2.
- 9.6) Install the vertical run of seal in the blockout following Steps 1 through 4. Ensure that the 16d (PENNY) 90° formed nails are properly seated within the corresponding cells.
- 9.7) Apply more Construction Specialties supplied Splice Sealant over the top of the splice.
- 9.8) Install 16d (PENNY) 90° formed nails in the top of the vertical seal using the Construction Specialties supplied instant adhesive.
- 9.9) Apply the Construction Specialties supplied Splice Sealant to the cut end of the vertical seal.
- 9.10) Mix the Epoxy and apply it to the top horizontal blockout areas as outlined in Step 2.
- 9.11) Place the end of the top horizontal section of seal in the blockout and press the first 5-6 inches [127.00mm-152.40mm] of the seal into the joint to align with the 16d (PENNY) 90° formed nails in the previously installed section.
- 9.12) Slide the seal against the end of the installed section so that the 16d (PENNY) 90° formed nails slide into the corresponding cells. Ensure that there is not a gap between the ends of the seals.
- 9.13) Place the remaining length of seal in the blockout and install according to Steps 2 and 3.
- 9.14) Apply more Construction Specialties supplied Splice Sealant over the top of the splices in accordance with Step 5.

STEP 10

TRANSITIONS

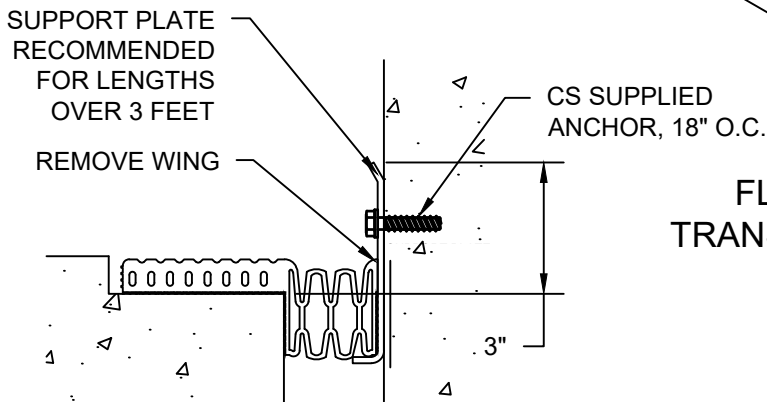
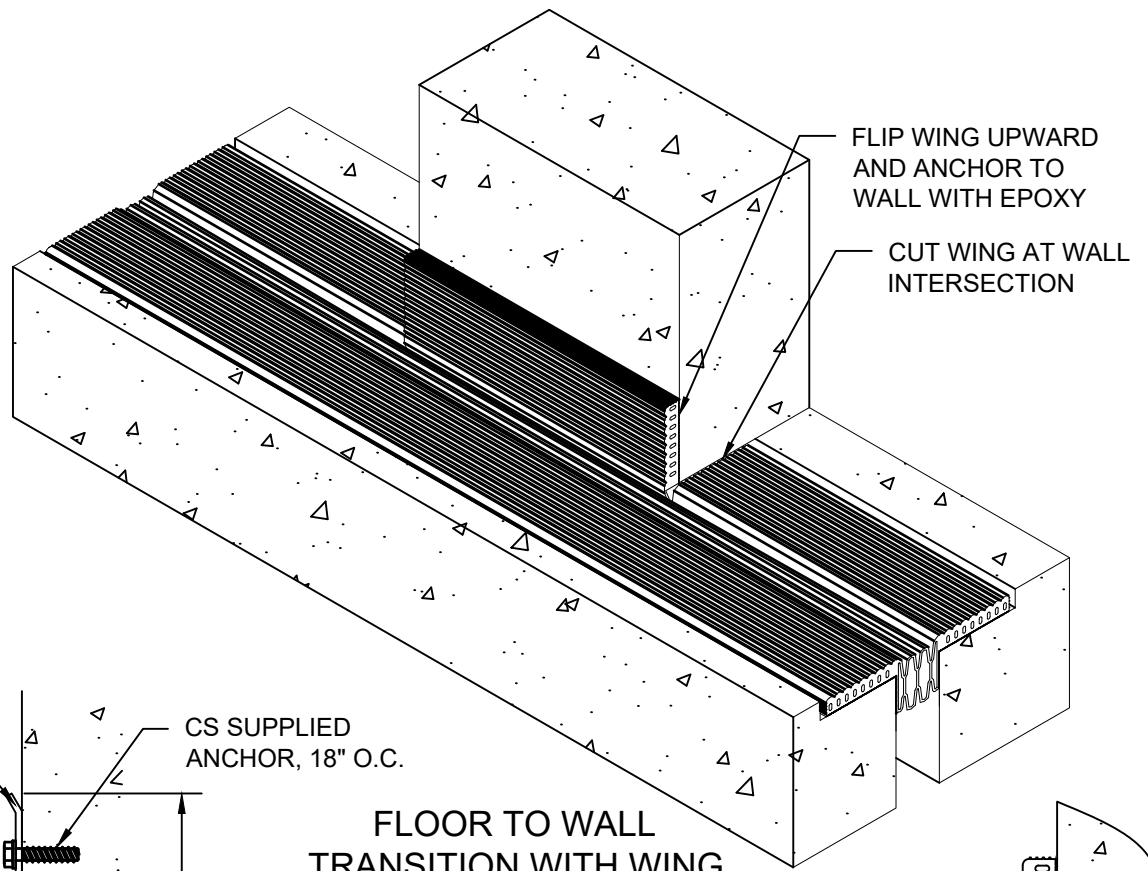

END VIEW

FLOOR TO WALL TRANSITION WITH WING REMOVED (RECOMMENDED)

FLOOR TO WALL TRANSITION WITH WING INTACT

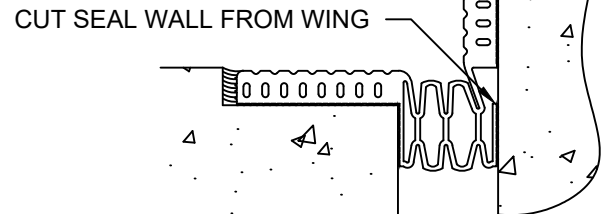

END VIEW

Step 10:

- 10.1) Cut through the width of the wing in the location where the seal will intersect a wall. Also, use a utility knife to cut the seal wall from the wing on the section to be flipped upward.
- 10.2) Install the run of seal according to Steps 1 through 5. Ensure that the cut sections of wing are flipped upward at the wall locations.
- 10.3) Apply Epoxy to the face of the wall where the wing will be located.
- 10.4) Place a weight, 4" x 4" [101.60mm x 101.60mm] lumber or equivalent object against the vertical wing to hold it in place until the epoxy cures.
- 10.5) Use the supplied Splice Sealant to cover any gaps or tears in the seal created by the transition.
- 10.6) Use the supplied Edge Sealant to fill any gaps between the substrate and seal created by the transition.

(RECOMMENDED OPTION):

- 10A.1) If using a support plate, install it using the CS supplied anchors in accordance with the anchor manufacturers instructions. The plate is to be installed so that the top edge is 3" [76.2mm] above the concrete blockout.
- 10A.2) Remove the sections of wing where the seal will intersect a wall.
- 10A.3) Install the seal according to steps 1 through 5. Be sure to apply Epoxy to the vertical face of the support plate to ensure the seal is bonded.

STEP 11

TRANSITIONS

REMOVE SEAL WINGS (IF USING ZB SEAL AT VERTICAL JOINT)
APPLY EPOXY TO INSIDE OF JOINT

EXTEND SEAL TO 1" BEYOND DEPTH OF VERTICAL SEAL.
APPLY EPOXY TO BOND SEAL TO CONCRETE

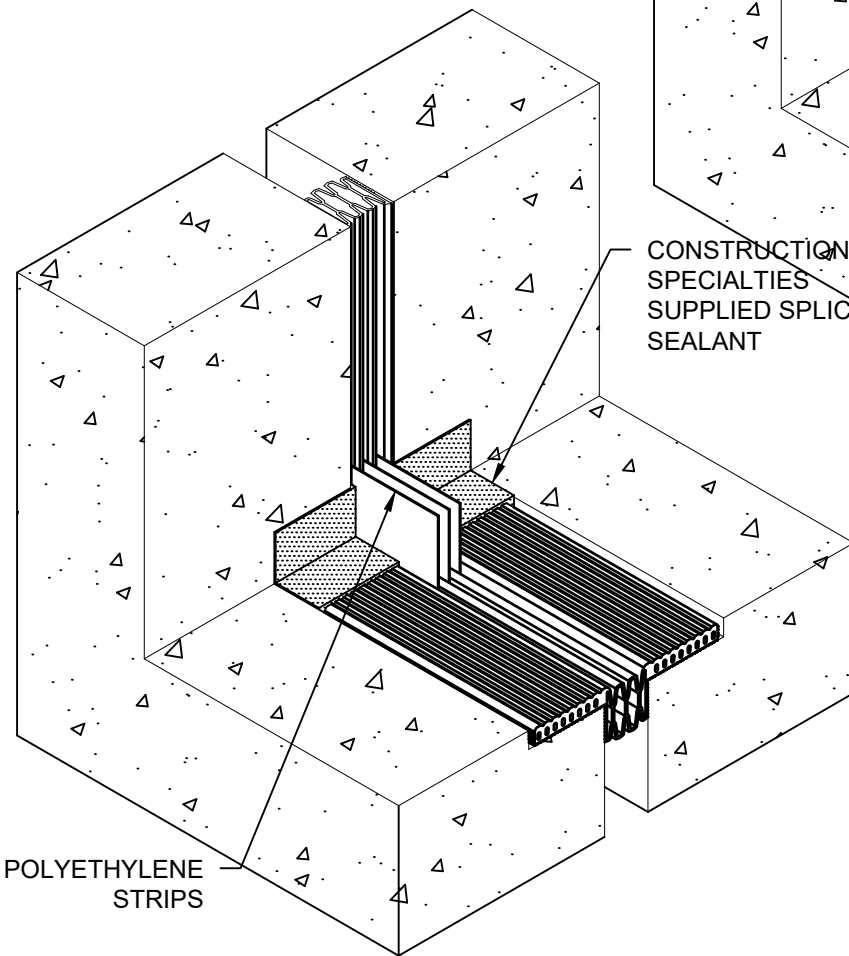
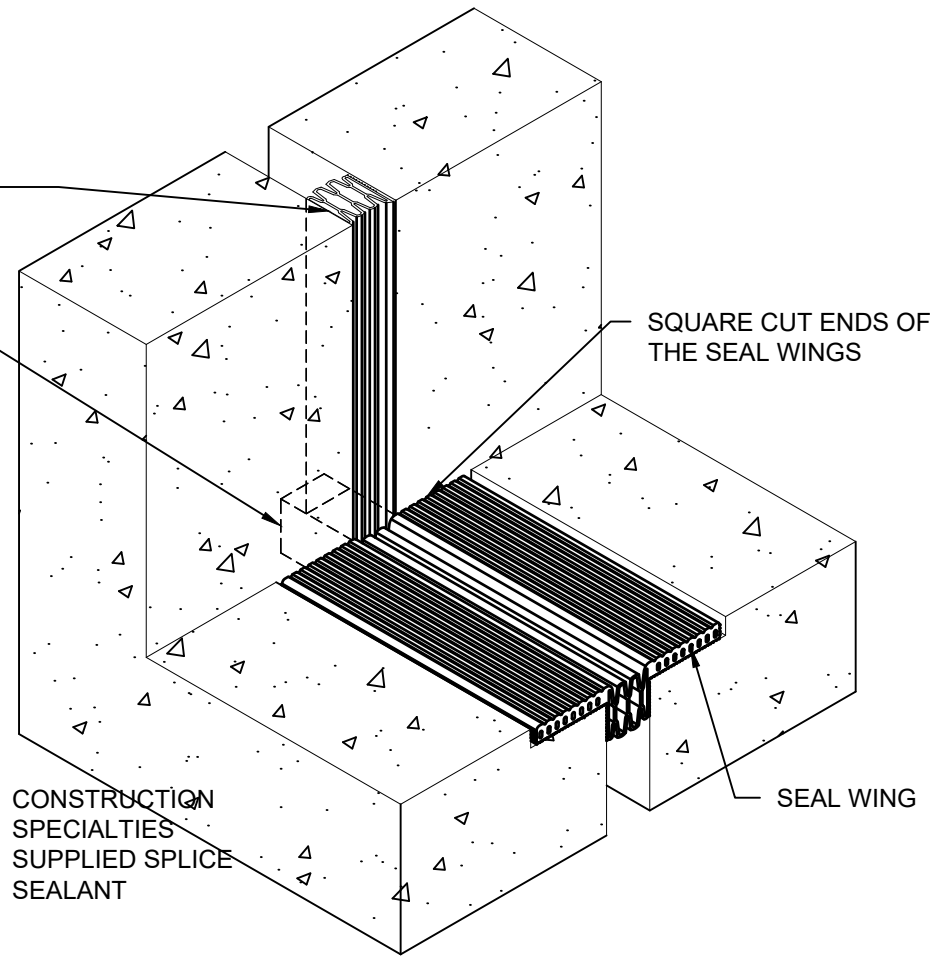

ZB (FLOOR) TO VERTICAL WALL TRANSITION

Step 11:

11.1) Remove wings at wall and install seal through wall to 1" beyond depth of wall seal.

11.2) Install the main run of seal according to Steps 1 through 5.

11.3) Apply the Construction Specialties supplied Splice Sealant to the area where the vertical seal will intersect with the horizontal seal.

11.4) Apply Epoxy to the walls of the vertical joint where the seal will be installed.

11.5) Press the seal into the vertical joint. Be sure to maintain a tight fit at the intersection.

11.6) Apply Construction Specialties supplied Splice Sealant over the top of the splice.

STEP 12

COMPLETE INSTALLATION

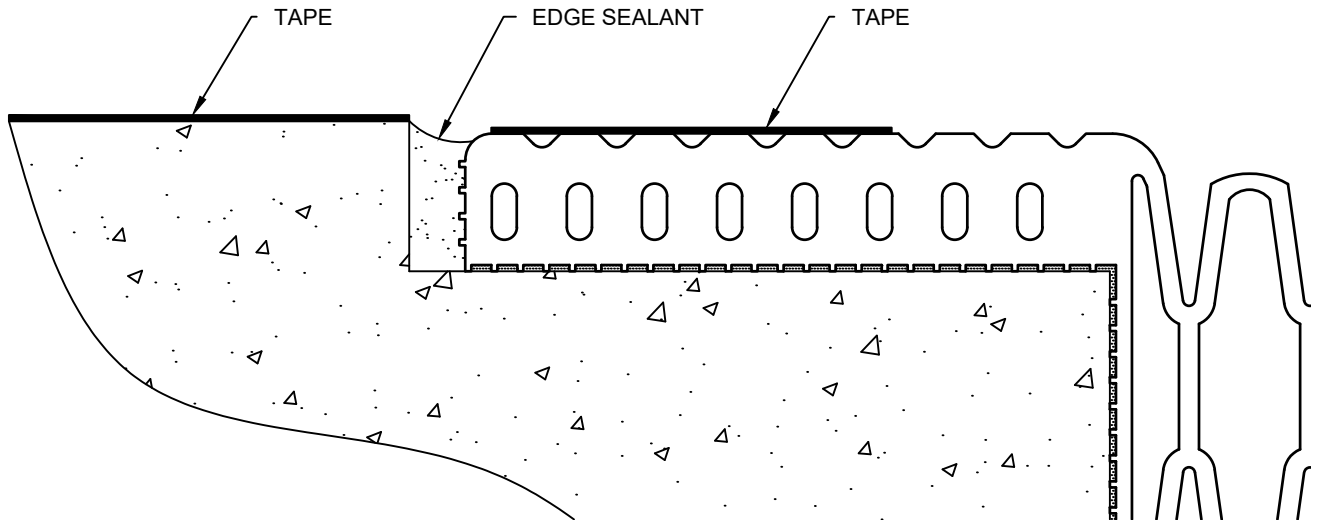

Step 12:

- 12.1) Prepare the seal for Edge Sealant by taping off the top edge of the seal and the concrete on each side of the joint.
- 12.2) Inject the Construction Specialties supplied Edge Sealant into the gap on each side of the seal. Ensure that the gap is filled from the bottom of the blockout to the top of the seal.
- 12.3) The Edge Sealant is self-leveling, therefore no tooling is required.
- 12.4) Remove all tape from the seal and concrete.