

EXTERIOR CARPET
M1EC
19C018XXX

HEAVY-DUTY CARPET
M1HC
19C010XXX

RUBBER
M1V
19V022501
#8501 BLACK

PEDIMAT INSERT STYLES

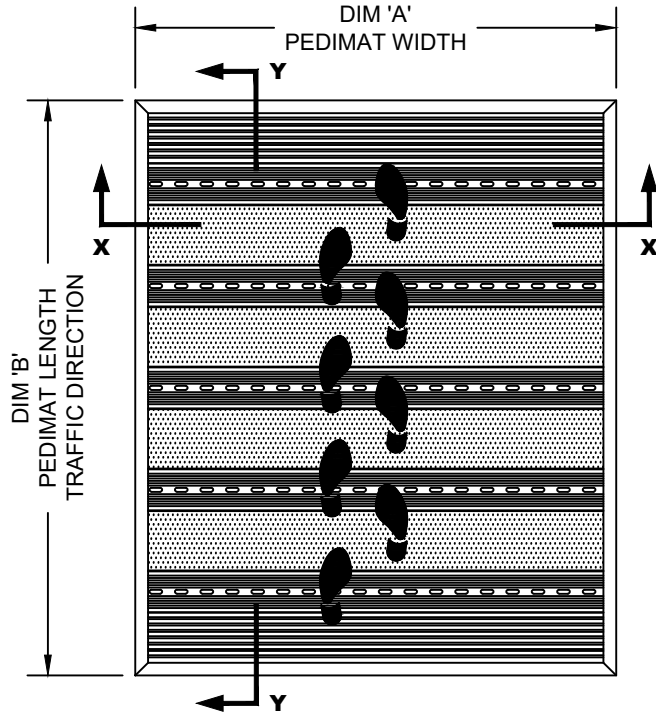

TYPICAL PLAN VIEW

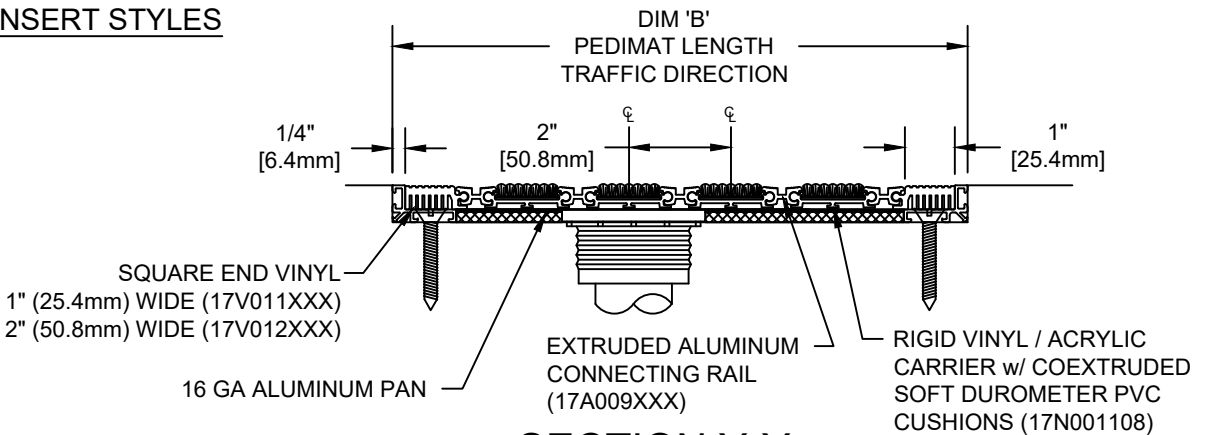

SECTION Y-Y

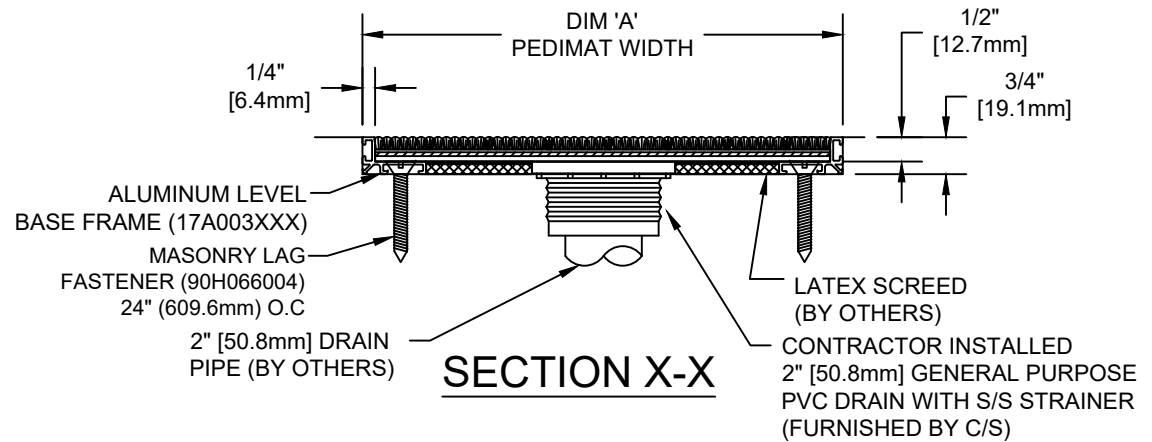

SECTION X-X

NOTES:

*ALL SURFACES IN CONTACT WITH MASONRY ARE TO RECEIVE A COAT OF ZINC CHROMATE PRIMER

*PLEASE VERIFY TRAFFIC DIRECTION

*PEDIMAT SHALL BE ABLE TO SUPPORT A 350 LB. ROLLING LOAD. LARGER LOADING MAY BE ACCOMODATED. CONTACT C/S SALES WITH SPECIFIC LOADING REQUIREMENTS.

*MAX. SINGLE GRID SIZE NOT TO EXCEED 12'-0" (3.66M) IN WIDTH (DIM "A") OR 100 SQUARE FEET

*ADDITIONAL SPECIFICATIONS ARE CONTAINED IN THE LATEST C/S CATALOG OR AT C-SGROUP.COM AND ARE CONSIDERED PART OF THIS TRANSMITTAL.

CS Construction Specialties™
 8696 Route 405 Highway, Muncy PA 17756
 (800) 233-8493 • Fax (570) 546-4692 • www.c-sgroup.com

PLEASE VERIFY ALL	QTY	MARK #	LOCATION	MODEL	DIM 'A' WIDTH	DIM 'B' LENGTH	FINISH	NOTES

PROJECT: _____

LOCATION: _____

CONTRACTOR: _____

AGENT: _____ SHT: _____

DRG. BY: _____ DATE: _____ JOB NO.: _____