

P-RASN HANDRAIL
WITH OPTIONAL S.S. END CAPS

PLEASE READ

PLEASE READ THESE INSTRUCTIONS THOROUGHLY PRIOR TO BEGINNING THE P-RASN HANDRAIL INSTALLATION!

THIS INSTRUCTION SHEET IS INTENDED TO PROVIDE A SPECIFIC GUIDE TO FOLLOW FOR THE INSTALLATION OF THIS P-RASN HANDRAIL. CONTAINED WITHIN IS THE TECHNICAL INFORMATION AND INSTALLATION TECHNIQUES REQUIRED TO COMPLETE AN EFFICIENT, NEAT AND LONG-LASTING INSTALLATION.

INSPECT ALL MATERIALS FOR DAMAGE OR MISSING PARTS. IF YOU DISCOVER DAMAGED OR MISSING MATERIALS, IN THE USA PLEASE NOTIFY THE FACTORY AT (800) 233-8493, AND IN CANADA (888) 895-8955 FOR CUSTOMER SERVICE.

P-RASN HANDRAIL MUST BE INSTALLED IN ACCORDANCE WITH THESE INSTRUCTIONS! FAILURE TO FOLLOW THESE INSTRUCTIONS MAY VOID ANY PRODUCT WARRANTIES AND RESULT IN AN UNSUCCESSFUL INSTALLATION. FOR SPECIFIC QUESTIONS REGARDING THE INSTALLATION OF THIS P-RASN HANDRAIL PLEASE CALL THE FACTORY IN THE USA AT (800) 233-8493 OR EMAIL IWPTECHSUPPORT@C-SGROUP.COM. IN CANADA CALL (888) 895-8955.

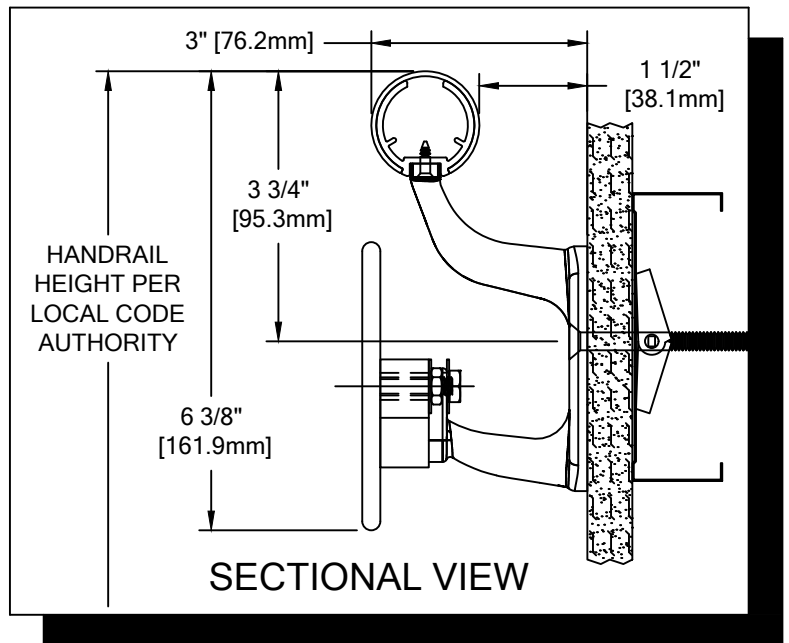

IMPORTANT NOTES

1. THIS HANDRAIL HAS BEEN MANUFACTURED TO CUSTOMER SPECIFIED DIMENSIONS AND CAN NOT BE CUT OR MODIFIED ON SITE. TO DO SO COULD VOID THE WARRANTY.
2. ALL DIMENSIONS ARE TYPICAL.
3. FOR DRYWALL/PLASTER WALL CONSTRUCTION, IT IS RECOMMENDED FOR FASTENERS TO BE ENGAGED INTO METAL/WOOD STUDS TO MAINTAIN MAXIMUM PULLOUT STRENGTH.
4. INSTALL OUTSIDE CORNERS FIRST.
5. INSTALL LONGEST RUN OF HANDRAIL FIRST.
6. ALUMINUM RETAINER SPLICE SHOULD NOT EXCEED 3" [76.2mm] DISTANCE FROM A BRACKET.
7. THE DISTANCE BETWEEN AN ACROVYN SPLICE JOINT AND AN ALUMINUM RETAINER SPLICE JOINT SHOULD NOT BE LESS THAN 12" [304.8mm].
8. MATERIAL MUST REACH 65°F MIN. TO 75° MAX. 24 HOURS PRIOR TO INSTALLATION. THIS IS ESSENTIAL TO MINIMIZE EXPANSION AND CONTRACTION.
9. MAY REQUIRE USE OF FIRE PUTTY WHEN INSTALLED ON FIRE WALL WITH TOGGLE BOLTS. REFERENCE INSTRUCTIONS 24FIREPUTTY FOR FIRE PUTTY INSTALLATION.
10. THIS HANDRAIL REQUIRES A MINIMUM OF 2 MOUNTING BRACKETS PER UNIT. THE MINIMUM END CAP-TO-END CAP HANDRAIL LENGTH IS 16" [406.4mm].
11. FOR MORE INFORMATION ON P-RASN HANDRAIL SEE OUR WEBSITE AT www.c-sgroup.com.

P-RASN HANDRAIL

COMPONENTS & WALL FASTENERS



ACROVYN COVER
(24U032xxx)
ACROVYN CHAMELEON
(24U610xxx)



ALUMINUM RETAINER
(24A095000)



STAINLESS STEEL
CRASH RAIL

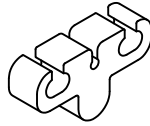

BRACKET ADAPTER PLATE
(24F230003)

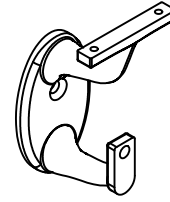

STAINLESS STEEL
MOUNTING BRACKET
(24S160000)

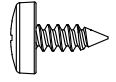

FASTENER #1
#8 X 3/8" PHILLIPS
PAN HEAD SMS
(90H069002)



FASTENER #2
#6 X 5/8" S/S PHILLIPS
FLAT HEAD SMS
(90H231004)

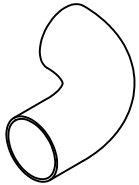

STAINLESS STEEL END CAP
(24S119000)



STAINLESS STEEL
INSIDE/OUTSIDE CORNER
(24S120000)

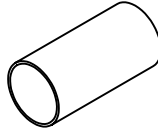

OPTIONAL STAINLESS
STEEL SPLICE
(24S122000)

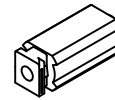

ALIGNMENT PLUG
(24I051000)

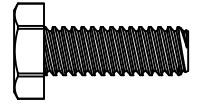

FASTENER #3
1/4"-20 X 3/4"
HEX HEAD MACHINE SCREW
(90H008002)

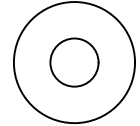

FASTENER #4
1/4" FLAT WASHER
(90H007003)



END CAP SPLINE
(24F194000)

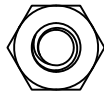

FASTENER #7
1/4-20 X 5/32"
JAM NUT
(90H010007)



FASTENER #8
1/4-20 X 4"
HEX HEAD BOLT
(90H068002)

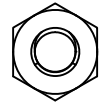

FASTENER #5
1/4"-20 HEX NUT
(90H010001)

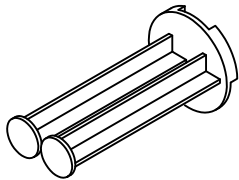

CAULKING GUN
CONVERSION KIT-PLUNGER
(90M023000)

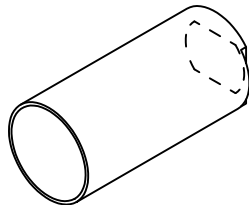

CAULKING GUN
CONVERSION KIT-SLEEVE
(90M023000)

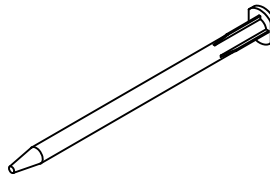

MIXING NOZZLE
(90M022000)

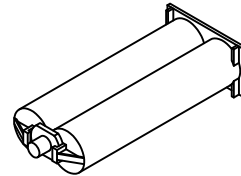

EPOXY
(90M089001)



FASTENER #6
SERRATED LOCK WASHER
(90H043003)

WALL CONDITION	SPECIFIED FASTENER	DRILL DIAMETERS		CS PART NUMBER
		WALL	RETAINER	
STEEL STUD/GYPSUM WALL	1/4-20 X 3" S/S FLAT HEAD BOLT WITH TOGGLE	3/4"	N/A	90H184002
CONCRETE/CONCRETE BLOCK	1/4" X 1 3/4" S/S FLAT HEAD MASONRY ANCHOR	3/16"	N/A	90H390000
WOOD STUD/GYPSUM WALL	#14 X 3" S/S PHILLIPS FLAT HEAD WOOD SCREW	7/32"	N/A	90H538004
20 GA. STEEL STUD/GYPSUM WALL (OSHPD)	1/4 - 20 X 3" S/S FLAT HEAD BOLT 1/4" TOGGLER WING 3M MOLDABLE FIRE PUTTY	1/2"	N/A	90H063002 90H062004 90M012000

P-RASN HANDRAIL

LAYOUT VIEW

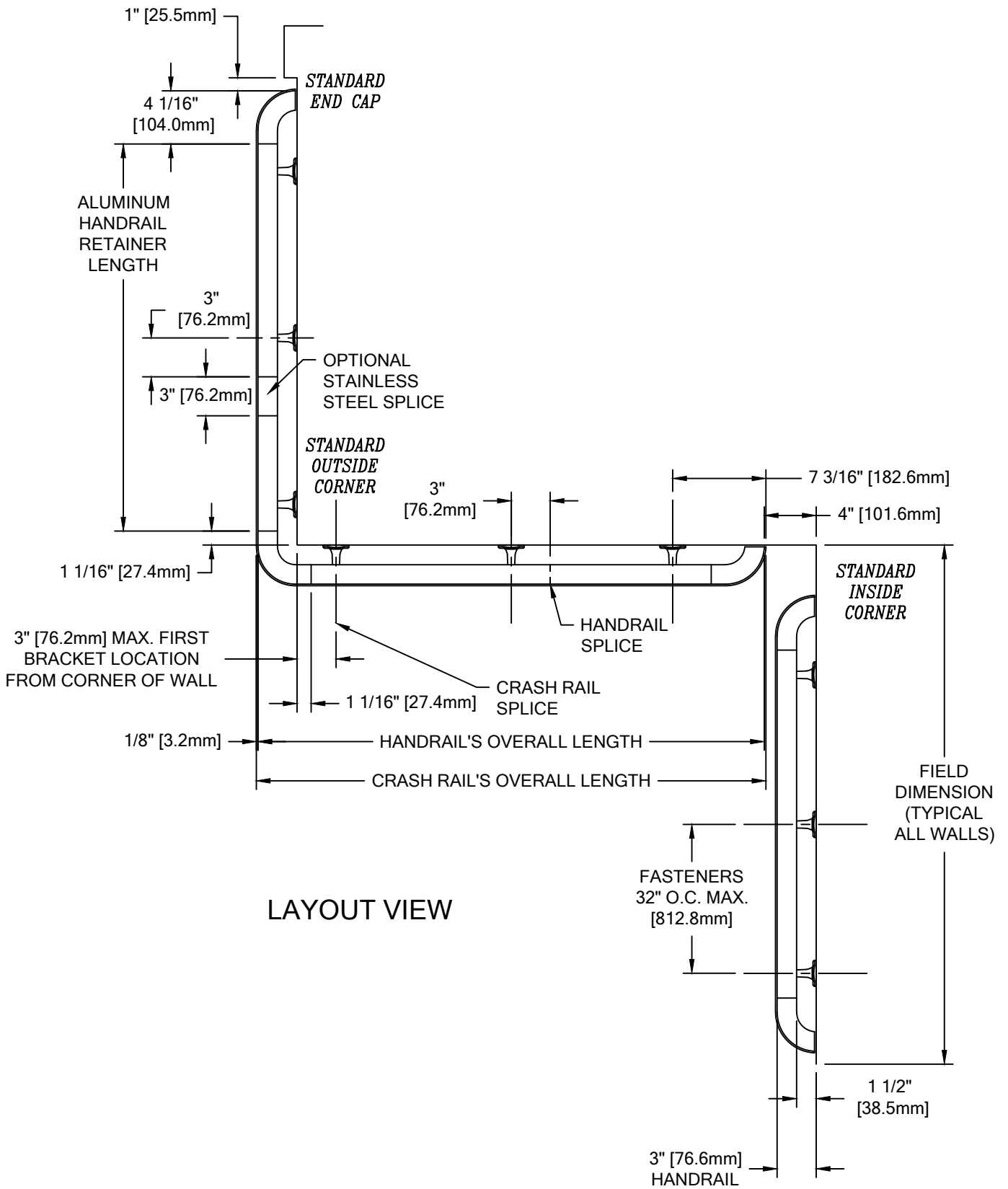

LAYOUT VIEW

P-RASN HANDRAIL

TYPICAL HANDRAIL ASSEMBLY

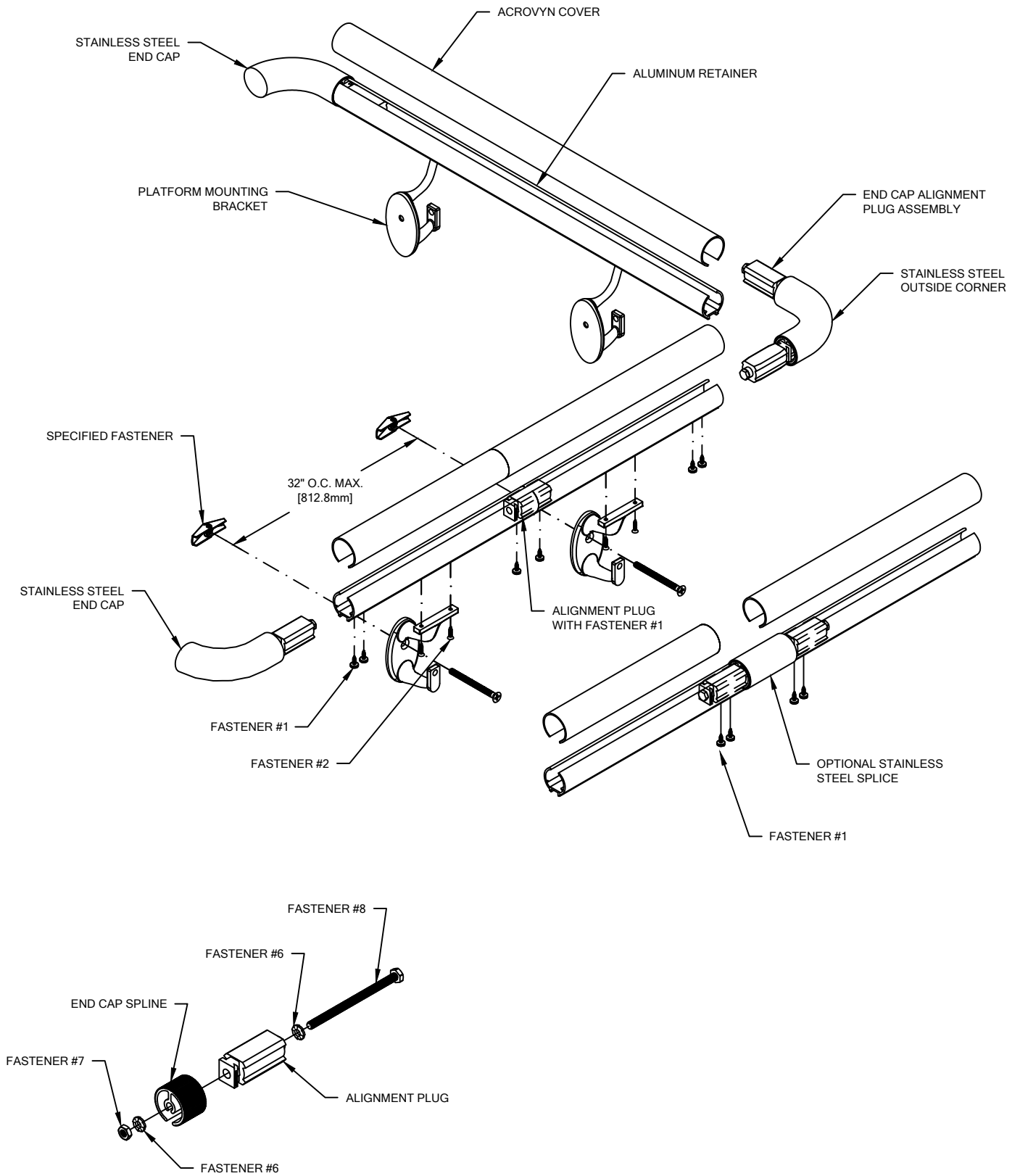

FIGURE 1.
END CAP ALIGNMENT PLUG ASSEMBLY

P-RASN HANDRAIL

TYPICAL HANDRAIL ASSEMBLY

NOTE: THIS MATERIAL HAS BEEN MANUFACTURED TO CUSTOMER SPECIFIED DIMENSIONS AND CAN NOT BE CUT OR MODIFIED ON SITE. TO DO SO COULD VOID THE WARRANTY.

1. USING "LOCAL CODE" REQUIREMENTS, ESTABLISH HANDRAIL ABOVE FINISH FLOOR. DEDUCT 3 3/4" [95.3mm] AND SNAP A CHALK LINE AT THAT HEIGHT. THIS MARKS THE LOCATION OF THE HOLE FOR THE MOUNTING BRACKET FASTENERS.
2. DRILL CLEARANCE HOLES IN WALL SURFACE FOR MOUNTING HARDWARE. REFERENCE CHART ON PAGE 2 FOR CORRECT DRILL DIAMETERS. TO AVOID MISALIGNMENT PROBLEMS, USE CRASH RAIL WITH ATTACHED BRACKETS AS A TEMPLATE TO MARK BRACKET LOCATIONS ON THE WALL, REFERENCE STEP #8.
3. INSTALL MOUNTING BRACKETS USING APPROPRIATE FASTENERS. USE A LEVEL TO ENSURE THAT THE BRACKETS ARE LEVEL. WARNING: MOUNTING BRACKET LOCATIONS MUST BE IDENTICAL TO THE FACTORY INSTALLED STUDS ON THE BACKSIDE OF THE CRASH RAIL.
4. ATTACH END CAPS AND INSIDE/OUTSIDE CORNERS (A FLAT SURFACE IS REQUIRED):
 - LOOSELY ASSEMBLE THE END CAP ALIGNMENT PLUG AS SEEN IN FIGURE 1.
 - INSERT END CAP ALIGNMENT PLUG INTO THE RETAINER AND ALIGN THE END CAP SPLINE WITH THE END OF THE RETAINER. ONCE ALIGNED TIGHTEN THE END CAP ALIGNMENT PLUG ASSEMBLY.
 - DRILL 1/8" DIAMETER PILOT HOLE THROUGH THE BOTTOM OF THE RETAINER AND END CAP ALIGNMENT PLUG, 5/8" [15.9mm] AND 1 1/4" [31.8mm] FROM THE END OF THE RETAINER FOR #8 X 3/8" PHILLIPS PAN HEAD SMS.
 - ATTACH END CAP ALIGNMENT PLUG TO RETAINER WITH THE ABOVE MENTIONED SCREW, UP THROUGH THE BOTTOM OF THE RETAINER.
 - TO PROTECT FINISHED SURFACES FROM ADHESIVE DURING ASSEMBLY APPLY MASKING TAPE TO EXTERIOR SURFACE OF END CAP (OR INSIDE/OUTSIDE CORNER).
 - USING 100 GRIT SANDPAPER, SAND THE INTERIOR SURFACE OF THE END CAP. CLEAN THE INTERIOR SURFACE OF END CAP WITH ISOPROPYL (RUBBING) ALCOHOL.
 - DRY FIT THE ALUMINUM SPLINE BEFORE APPLYING ADHESIVE. ONCE TESTED REMOVE AND APPLY 1/8" BEAD OF ADHESIVE TO SANDED, INTERIOR SURFACE (REFERENCE CAULKING GUN CONVERSION KIT FIGURES 4 & 5) AND PERMANENTLY ATTACH TO ALUMINUM SPLINE. CAUTION: SERRATED LOCK WASHER MUST BE SECURELY TIGHTENED AND EMBEDDED INTO ALUMINUM SPLINE TO PREVENT ATTACHED END CAP FROM ROTATING.
 - THE ADHESIVE ONLY ALLOWS FOR 8 TO 12 MINUTES OF WORKING TIME. INSTALL END CAP (OR INSIDE/OUTSIDE CORNER) OVER ALUMINUM SPLINE. FOR A PROPER SEAM, STAINLESS STEEL END CAP (OR INSIDE/OUTSIDE CORNER) MUST BE TIGHTLY FITTED TO THE HANDRAIL. PARTS CAN BE HANDLED IN 1 1/2 HOURS AND WILL BE FULLY CURED AFTER 24 HOURS.
 - OPTIONAL STAINLESS STEEL SPLICE WILL BE INSTALLED IN THE SAME MANNER.
5. DRILL 1/16" PILOT HOLES INTO THE RETAINER FOR MOUNTING BRACKET ATTACHMENT. MOUNTING BRACKETS ARE TO BE LOCATED 3" [76.2mm] FROM EACH END OF THE RETAINER AND 32" [612.6mm] ON CENTER ALONG LENGTH, AS REQUIRED.
6. FASTEN THE ALUMINUM RETAINER TO THE WALL BRACKETS IN SUCCESSION BY INSERTING TWO #6 X 5/8" S/S PHILLIPS FLAT HEAD SHEET METAL SCREWS THROUGH THE UNDERSIDE OF BRACKET INTO THE RETAINER. CAUTION: OVER-TORQUEING MAY CAUSE THE FASTENERS TO STRIP.
7. STARTING AT ONE END, SNAP THE ACROVYN COVER ONTO THE RETAINER ALONG THE LENGTH OF THE HANDRAIL.

NOTE: MANUFACTURING RECOMMENDS ALL PRINTED "PRODUCT IDENTIFICATION" ON THE REAR OF THE ACROVYN PROFILE SHALL BE ORIENTED IN THE SAME DIRECTION DURING INSTALLATION TO ENSURE PROPER ALIGNMENT AT SPLICE BUTT JOINTS.

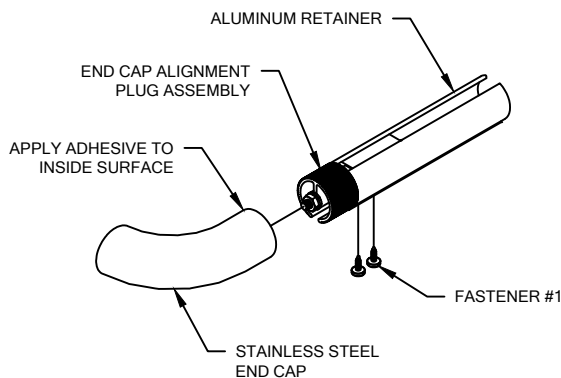

FIGURE 2.

NOTE: IT MAY BE NECESSARY TO USE A FILE AND EASE THE BOTTOM EDGE OF THE STAINLESS STEEL END CAP. (SEE FIGURE 3)

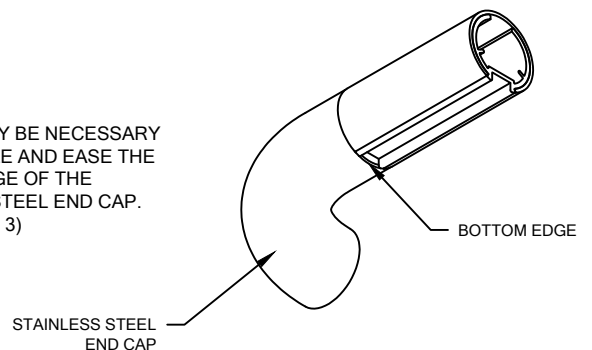
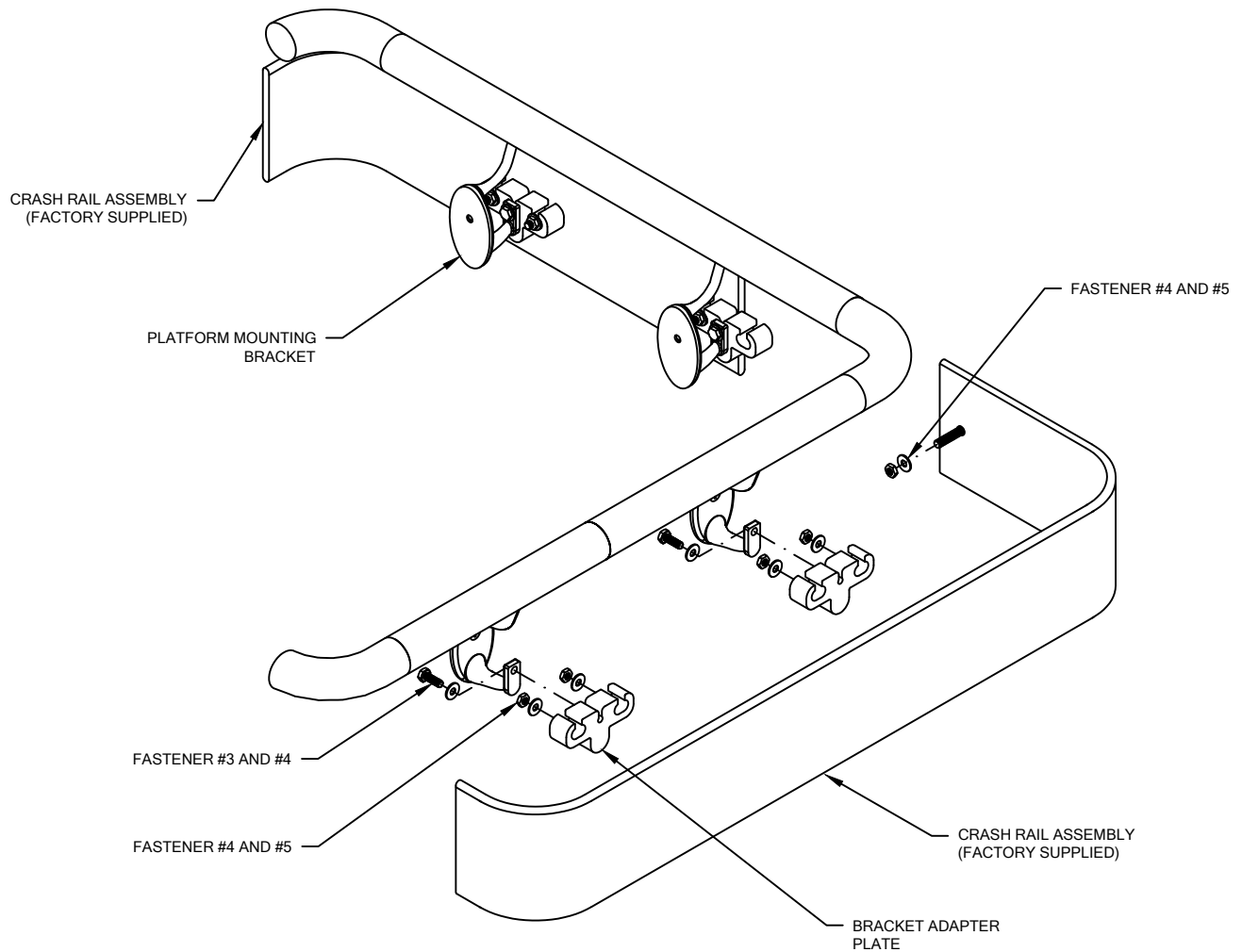

FIGURE 3.

P-RASN HANDRAIL

TYPICAL CRASH RAIL ASSEMBLY



8. ATTACH CRASH RAIL TO THE WALL MOUNTING BRACKETS:
 - DISTRIBUTE MATERIAL. MATCH THE NUMBER ON THE BACK OF THE RAIL TO THE MARK NUMBER ON THE DRAWING. SOME LARGE RUNS REQUIRE MORE THAN ONE PIECE OF CRASH RAIL. THESE ARE NOTED WITH A MARK NUMBER AND A LETTER, I.E., 2001A, 2001B.
 - LOCATE A BRACKET ADAPTER PLATE ON EACH SET OF THREADED STUDS ON THE BACKSIDE OF THE CRASH RAIL.
 - SECURE THE BRACKET ADAPTER PLATE BY INSTALLING A 1/4" WASHER AND 1/4-20 NUT ONTO EACH THREADED STUD.
 - ALIGN EACH MOUNTING BRACKET WITH THE BRACKET ADAPTER PLATE'S THREADED HOLE.
 - INSERT 1/4-20 HEX HEAD BOLT AND 1/4" WASHER THROUGH THE MOUNTING BRACKET AND INTO THE MOUNTING BRACKET'S THREADED HOLE. THE BRACKET ADAPTER PLATE IS SLOTTED TO ACCOMMODATE ANY SLIGHT MISALIGNMENT.
 - FASTENERS MUST BE TORQUED TO 150 IN/LBS.

P-RASN HANDRAIL

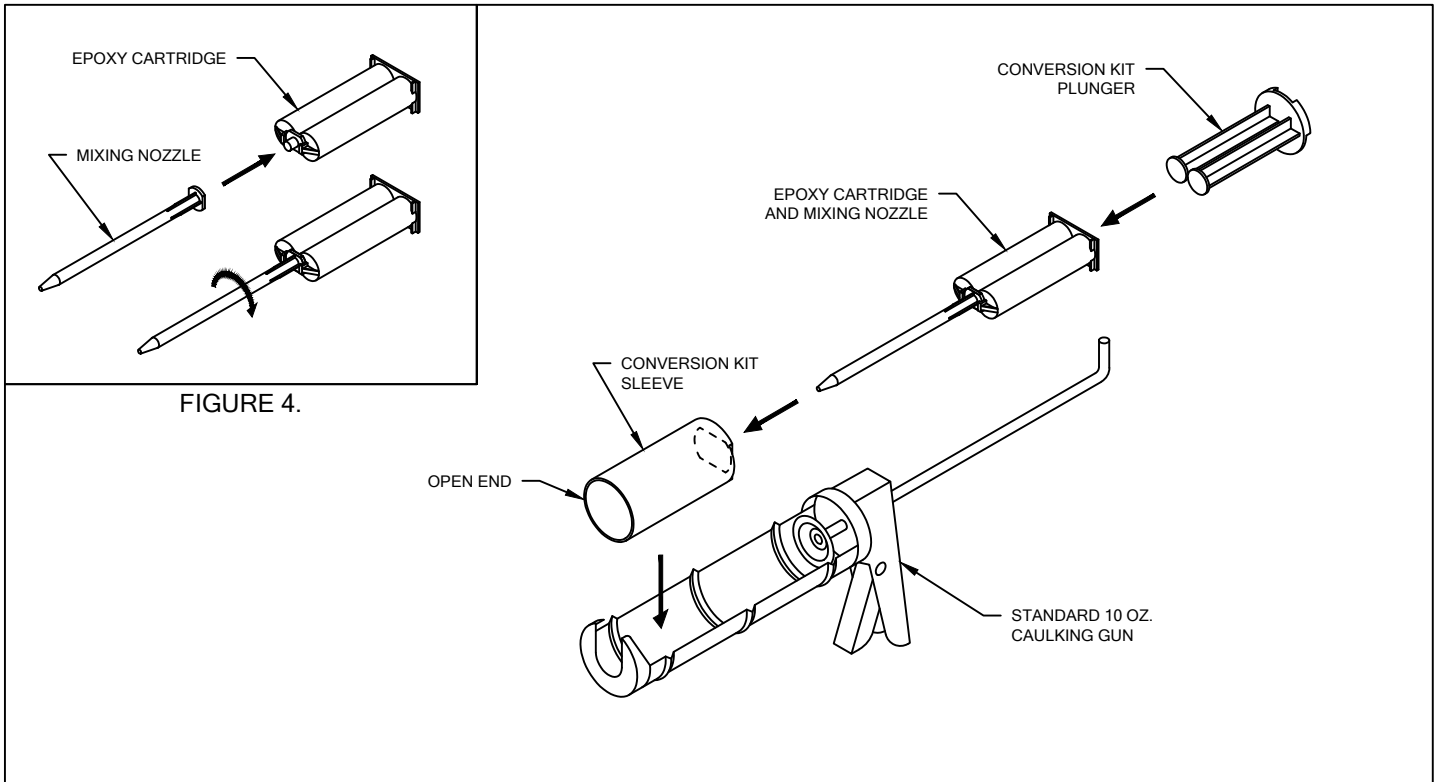

FIGURE 4.

FIGURE 5.

CAULKING GUN CONVERSION KIT

EPOXY CARTRIDGE AND MIXING NOZZLE. REFER TO FIGURE 4.

1. REMOVE CAP AND GASKET FROM THE END OF EPOXY CARTRIDGE BY TWISTING 90°.
2. INSTALL MIXING NOZZLE ON THE FRONT OF EPOXY CARTRIDGE AND LOCK IN PLACE BY TWISTING 90°.

CAULKING GUN CONVERSION KIT. REFER TO FIGURE 5.

1. INSERT EPOXY CARTRIDGE AND MIXING NOZZLE INTO OVAL OPENING OF SLEEVE. NOTE THE LOCATION OF OPEN END.
2. PLACE PLUNGER IN THE BACK END OF CARTRIDGE.
3. PLACE THE CONVERSION KIT, WITH MIXER NOZZLE AND EPOXY CARTRIDGE, IN A STANDARD 10 OZ CAULKING GUN AS SHOWN IN FIGURE 5. PLUNGER WILL ATTACH TO CIRCULAR PUSH PLATE ON CAULKING GUN.

10/28/16