

# MODEL GFPS & GFPSW

## 100 THRU 200 INSTALLATION

### INSTRUCTIONS

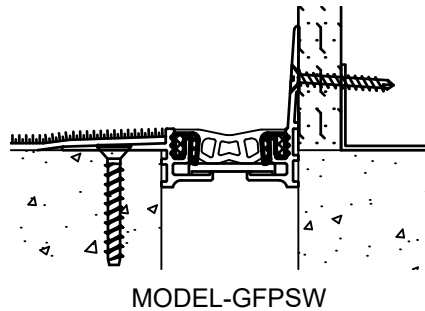
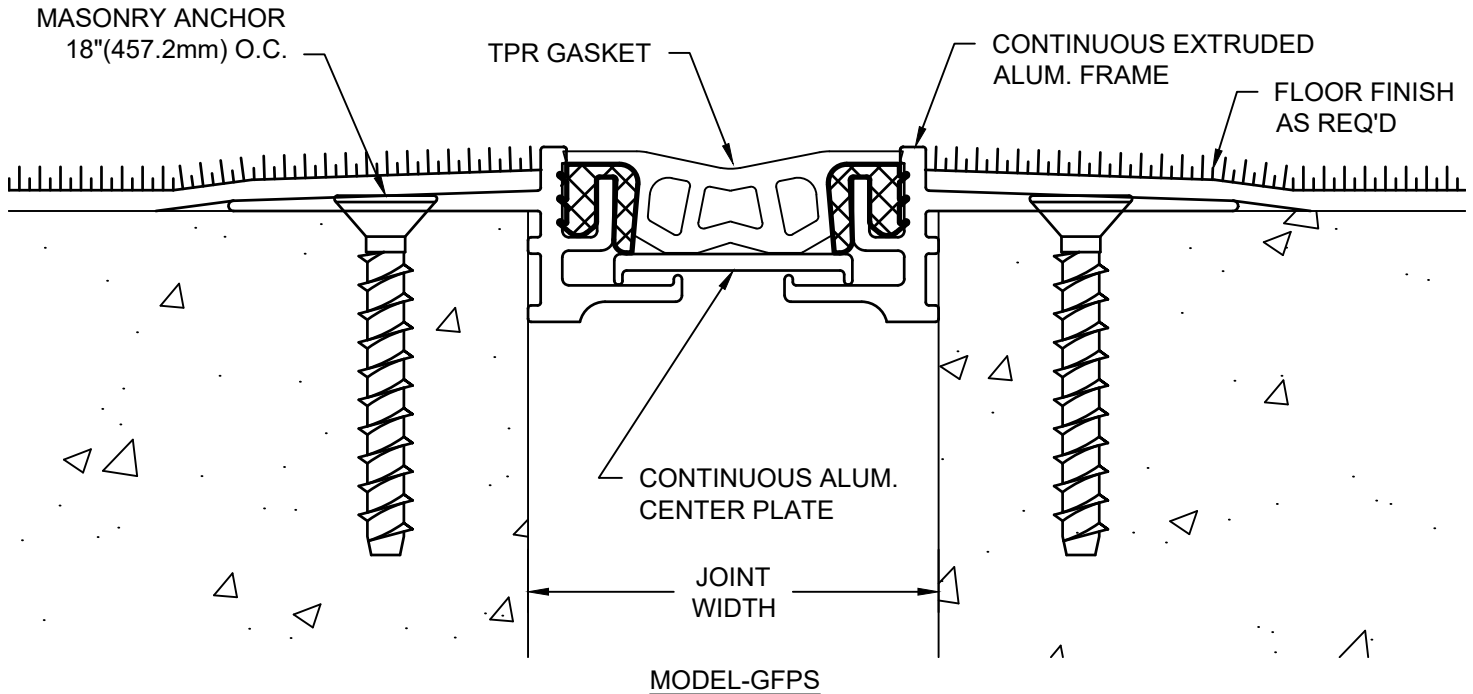

## IMPORTANT INFORMATION

Prior to the commencement of Installation, all materials **MUST** be inspected for Damage. Any damage must be reported to CONSTRUCTION SPECIALTIES, INC., as soon as possible, so that replacement materials may be furnished without delay.

All work must be completed as per Architect's Approved "Shop Drawings", and in accordance with these Installation Instructions. When installation is complete, all materials must be protected from damage until the Architect's FINAL INSPECTION.

### IMPORTANT:

**READ THROUGH ALL INSTRUCTIONS PRIOR TO STARTING INSTALLATION**

All materials should be arranged in the order that they are to be installed. All hardware required for each portion of the work should be placed with the appropriate materials.

Please review all Approved Shop Drawings and this Document to familiarize yourself with all the details and components of this assembly.

4/3/25



**Construction Specialties™**

6696 Route 405 Highway, Muncy PA 17756  
(800) 233-8493 • Fax (570) 546-5169  
www.c-sgroup.com

This document is the property of Construction Specialties, Inc. and contains CONFIDENTIAL PROPRIETARY INFORMATION that is not to be disclosed to third parties and is not to be used without approval in writing from Construction Specialties, Inc.

Notes:

Before beginning installation, review the architectural drawings and approved Construction Specialties Inc. shop drawings to familiarize yourself with the joint cover models and locations.

Check all of the joint cover components to confirm that the correct joint cover model and size have been received. Also, check for materials that may have been damaged during shipping. Report all incorrect and/or damaged components to C/S at 800-233-8493.

Read through all the steps of these instructions prior to beginning work.

# STEP 1

## FLOOR INSTALLATION

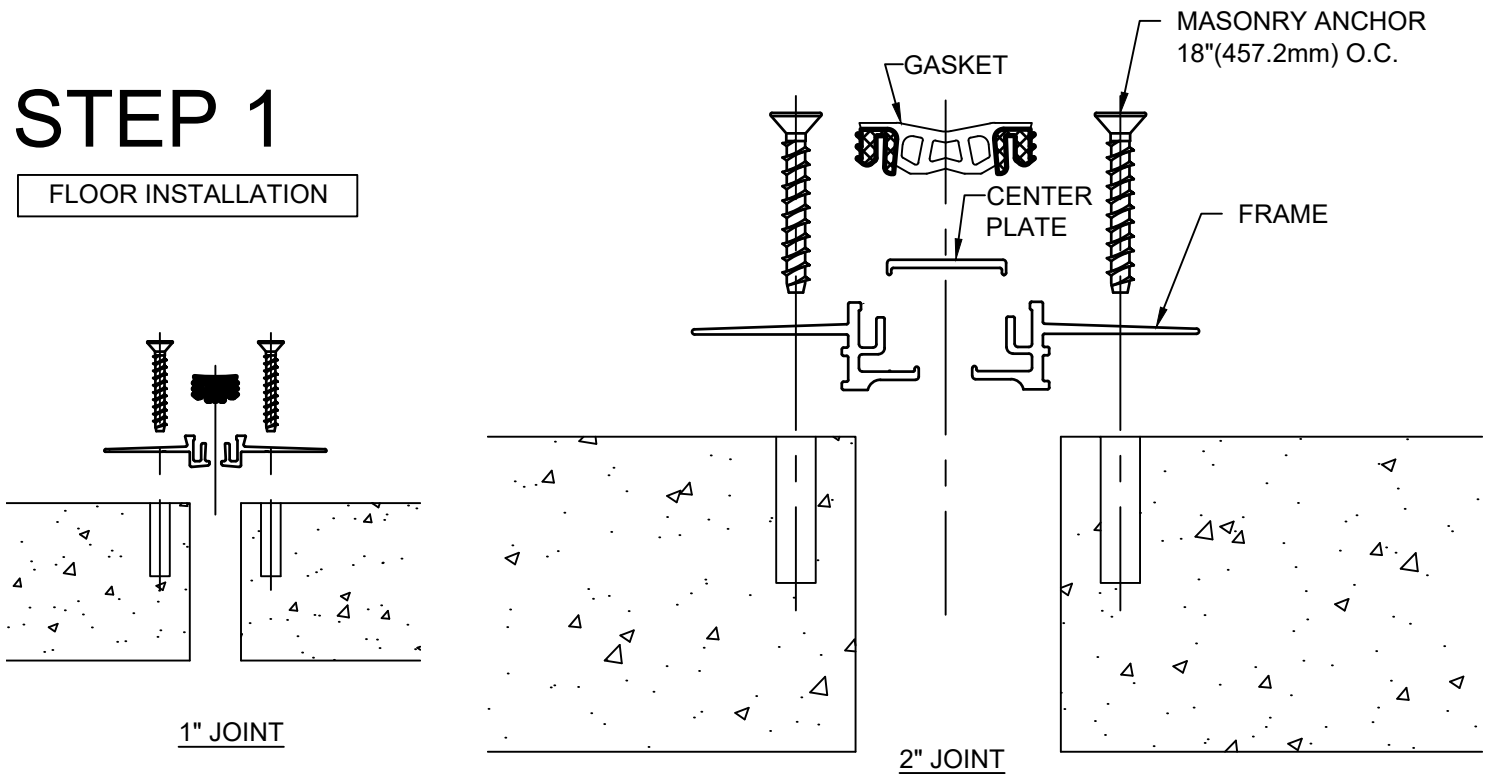

Notes:

-If a C/S Fire Barrier is to be installed in the joint, please review the Fire Barrier Installation Instructions supplied, and if required install the Fire Barrier **BEFORE** installation of C/S Seismic Expansion Joint Aluminum Frames.

-If a Vapor Barrier is to be installed in the joint, please review the Vapor Barrier Installation Instructions supplied, and if required install the Vapor Barrier **BEFORE** installation of C/S Seismic Expansion Joint Aluminum Frames.

Note: Model GFPS 200 will require installation of center plate into frames.

### 1.1) Methods of Installation:

- A) Cut several 2" pieces of seal to be used as spacers. Install spacers into frames. Cut assembly to length as needed for the run.
- B) Cut the length of seal as needed for the run and install into the aluminum frames.

### Recommended Installation Tips for Seal:

- 1) Unroll seal material and allow exposure to sun to soften, becoming more pliable. Spray the back of the seal with a soapy water solution, to aid in installation.
- 2) Soak seal in a hot water bath to soften seal.

1.2) Using the Assembly (Frames and seal) as a template, mark the locations of the fasteners. Remove the Assembly and drill the holes for the anchor bolts. The holes are to be drilled with the appropriate size and type of drill bit as indicated on the C/S Shop Drawings or by the manufacturer of the C/S supplied fasteners.

1.3) Reposition and attach the Frames to the slab with the C/S supplied anchor bolts following the manufacturer's guidelines.

1.4) If 2" Spacers were used in frames, remove spacers once frames are installed. Insert continuous seal lengths, using tips above, into the frames. Seal can be engaged using a rubber mallet and wood block. (A seam roller may also be used to engage seal)

1.5) Repeat this installation procedure for any additional lengths of the assembly.

# STEP 2

## FLOOR TO WALL INSTALLATION

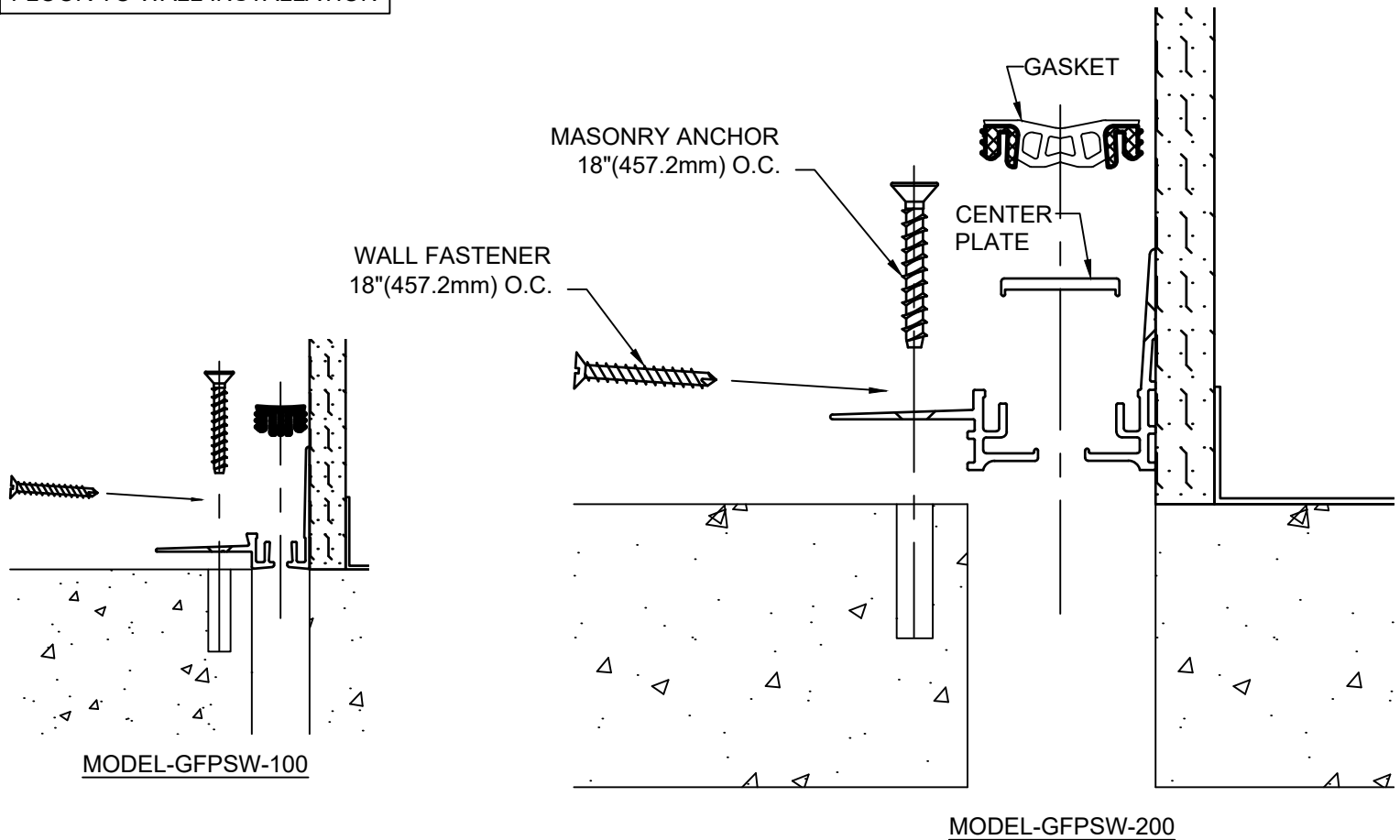

### Notes:

-If a C/S Fire Barrier is to be installed in the joint, please review the Fire Barrier Installation Instructions supplied, and if required install the Fire Barrier **BEFORE** installation of C/S Seismic Expansion Joint Aluminum Frames.

-If a Vapor Barrier is to be installed in the joint, please review the Vapor Barrier Installation Instructions supplied, and if required install the Vapor Barrier **BEFORE** installation of C/S Seismic Expansion Joint Aluminum Frames.

Note: Model GFPSW 200 will require installation of center plate into frames.

### 2.1) Methods of Installation:

- A) Cut several 2" pieces of seal to be used as spacers. Install spacers into frames. Cut assembly to length as needed for the run.
- B) Cut the length of seal as needed for the run and install into the aluminum frames.

### Recommended Installation Tips for Seal:

- 1) Unroll seal material and allow exposure to sun to soften, becoming more pliable. Spray the back of the seal with a soapy water solution, to aid in installation.
- 2) Soak seal in a hot water bath to soften seal.

- 2.2) Using the Assembly (Frames and seal) as a template, mark the locations of the fasteners. Remove the Assembly and drill the holes for the anchor bolts. The holes are to be drilled with the appropriate size and type of drill bit as indicated on the C/S Shop Drawings or by the manufacturer of the C/S supplied fasteners.
- 2.3) Reposition and attach floor frame to the slab with the supplied anchor bolt following the manufactures's guidelines. Attach the wall frame to the surface of the wall using C/S supplied wall fasteners.
- 2.4) If 2" Spacers were used in frames, remove spacers once frames are installed. Insert continuous seal lengths, using tips above, into the frames. Seal can be engaged using a rubber mallet and wood block. (A seam roller may also be used to engage seal)
- 2.5) Repeat this installation procedure for any additional lengths of the assembly.

# STEP 3

## COMPLETE INSTALLATION

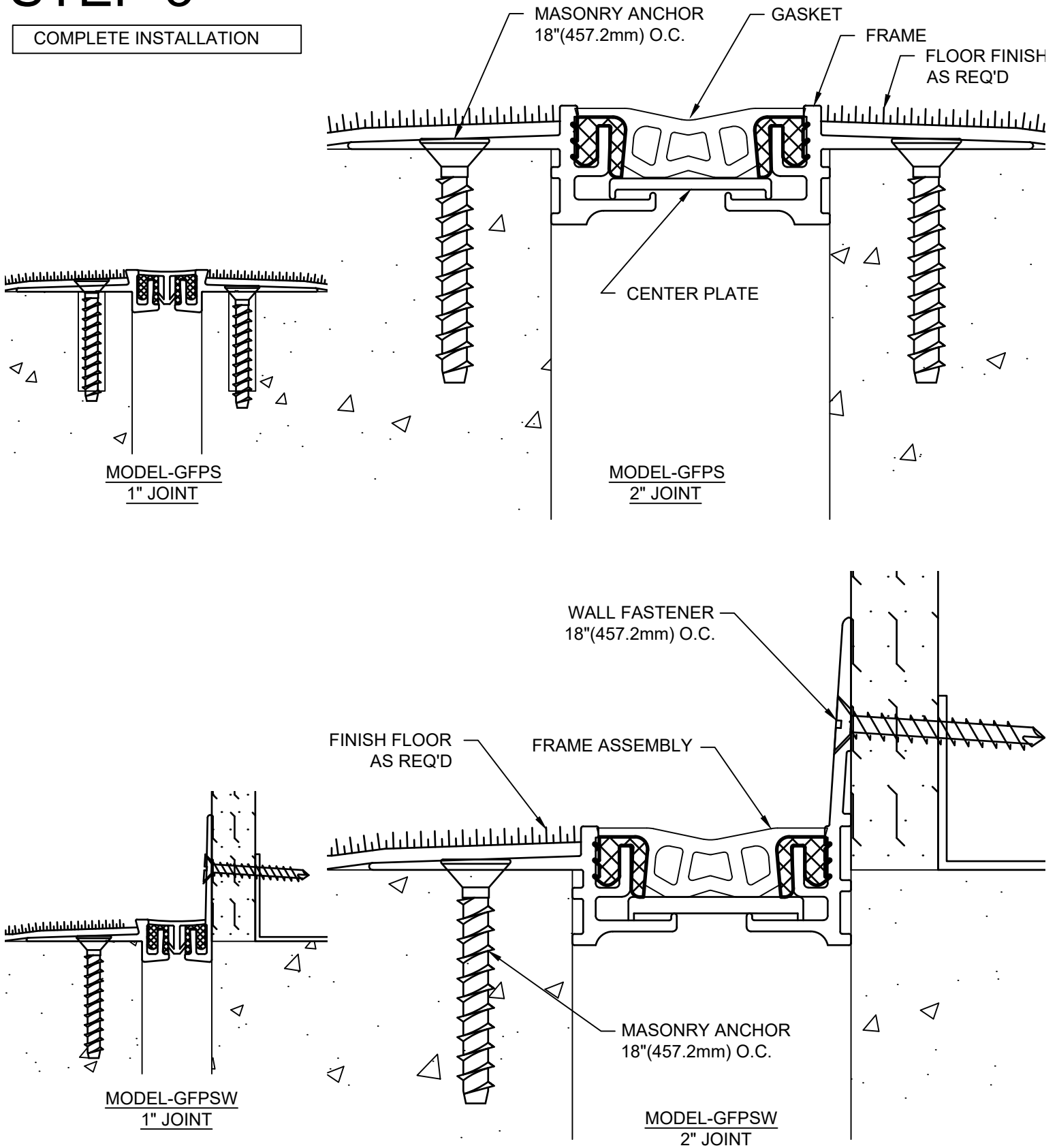

- 3.1) When installation of the C/S Floor Expansion Joint Cover has been completed, remove all residue and foreign matter from the area and joint cover.
- 3.2) Apply the appropriate floor finish as req'd according to C/S shop drawings.
- 3.3) Clean the C/S Joint Cover and adjoining surfaces with proper cleaner.
- 3.4) Protect the Joint Cover until the Architect's final inspection.