

**HRS-6C HANDRAIL**

PLEASE READ

PLEASE READ THESE INSTRUCTIONS THOROUGHLY PRIOR TO BEGINNING THE HRS-6C HANDRAIL INSTALLATION!

THIS INSTRUCTION SHEET IS INTENDED TO PROVIDE A SPECIFIC GUIDE TO FOLLOW FOR THE INSTALLATION OF THIS HRS-6C HANDRAIL. CONTAINED WITHIN IS THE TECHNICAL INFORMATION AND INSTALLATION TECHNIQUES REQUIRED TO COMPLETE AN EFFICIENT, NEAT AND LONG-LASTING INSTALLATION.

INSPECT ALL MATERIALS FOR DAMAGE OR MISSING PARTS. IF YOU DISCOVER DAMAGED OR MISSING MATERIALS, IN THE USA PLEASE NOTIFY THE FACTORY AT (800) 233-8493, AND IN CANADA (888) 895-8955 FOR CUSTOMER SERVICE.

HRS-6C HANDRAIL MUST BE INSTALLED IN ACCORDANCE WITH THESE INSTRUCTIONS! FAILURE TO FOLLOW THESE INSTRUCTIONS MAY VOID ANY PRODUCT WARRANTIES AND RESULT IN AN UNSUCCESSFUL INSTALLATION. FOR SPECIFIC QUESTIONS REGARDING THE INSTALLATION OF THIS HRS-6C HANDRAIL PLEASE CALL THE FACTORY IN THE USA AT (800) 233-8493 OR EMAIL IWPTECHSUPPORT@C-SGROUP.COM. IN CANADA CALL (888) 895-8955 .

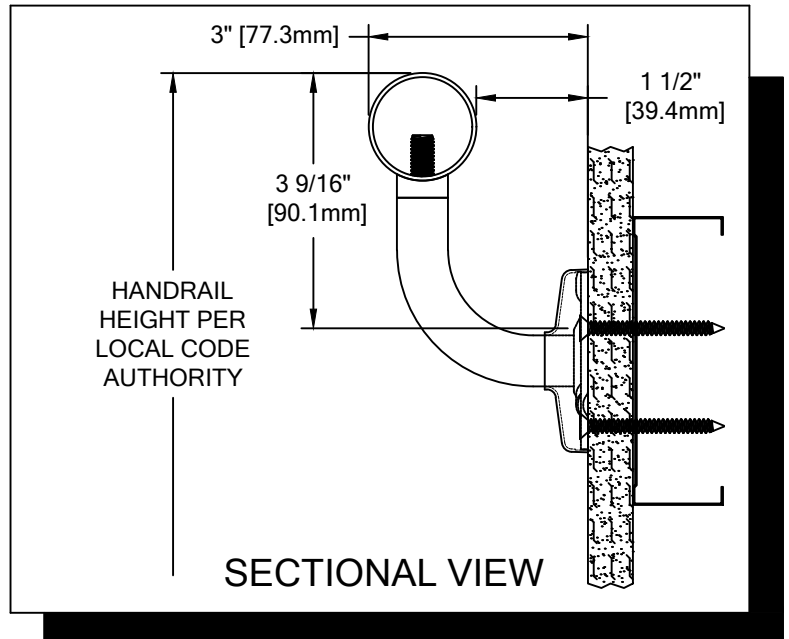

IMPORTANT NOTES

1. THIS MATERIAL HAS BEEN MANUFACTURED TO CUSTOMER SPECIFIED DIMENSIONS AND CAN NOT BE CUT OR MODIFIED ON SITE. TO DO SO COULD VOID THE WARRANTY.
2. ALL DIMENSIONS ARE TYPICAL.
3. FOR DRYWALL/PLASTER WALL CONSTRUCTION, IT IS RECOMMENDED FOR FASTENERS TO BE ENGAGED INTO METAL/WOOD STUDS TO MAINTAIN MAXIMUM PULLOUT STRENGTH. IF DURING INSTALLATION YOU ENCOUNTER SPECIAL WALL CONDITIONS THAT DO NOT ALLOW FOR DIRECT ATTACHMENT TO STUDS PLEASE CONSULT THE LOCAL AUTHORITY HAVING JURISDICTION.
4. INSTALL OUTSIDE CORNERS FIRST.
5. INSTALL LONGEST RUN OF HANDRAIL FIRST.
6. STAINLESS STEEL HANDRAIL SPLICE SHOULD NOT EXCEED 3" [76.2mm] DISTANCE FROM A BRACKET.
7. MATERIAL MUST REACH 65°F MIN. TO 75°F MAX. 24 HOURS PRIOR TO INSTALLATION. THIS IS ESSENTIAL TO MINIMIZE EXPANSION AND CONTRACTION.
8. THIS HANDRAIL REQUIRES A MINIMUM OF 2 MOUNTING BRACKETS PER UNIT. THE MINIMUM END CAP-TO-END CAP HANDRAIL LENGTH IS 14 3/8" [365.1mm].
9. FOR MORE INFORMATION ON HRS-6C HANDRAIL SEE OUR WEBSITE AT [www.c-sgroup.com](http://www.c-sgroup.com).

**HRS-6C HANDRAIL**

COMPONENTS & WALL FASTENERS



STAINLESS STEEL  
HANDRAIL  
(80M160001)



END CAP SPLINE  
(24F219000)

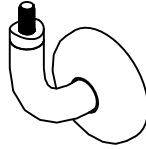

STAINLESS STEEL  
MOUNTING BRACKET  
(24S061000)

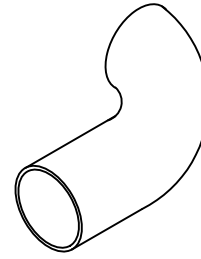

STAINLESS STEEL ENDCAP  
(24S193000)

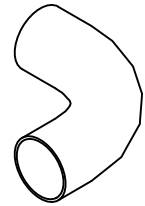

STAINLESS STEEL  
INSIDE/OUTSIDE CORNER  
(24S120000)

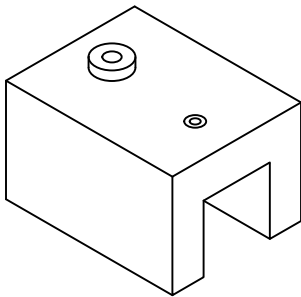

MOUNTING BRACKET JIG  
(90H221010)



8mm X 1.25mm PLUG TAP  
(90H086010)



O-RING GASKET  
(241107108)

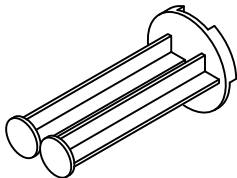

CAULKING GUN  
CONVERSION KIT  
PLUNGER  
(90M023000)

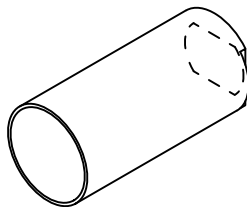

CAULKING GUN  
CONVERSION KIT  
SLEEVE  
(90M023000)

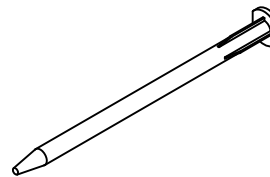

MIXING NOZZLE  
(90M022000)

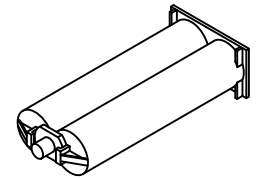

EPOXY  
(90M089001)

WALL CONDITION	SPECIFIED FASTENER	DRILL DIAMETERS		CS PART NUMBER
		WALL	RETAINER	
STEEL STUD/GYPSUM WALL	#10 X 2" PHILLIPS FLAT HEAD SHEET METAL SCREW	1/16"	N/A	90H431002
CONCRETE/CONCRETE BLOCK	1/4" X 2 1/4" HEX HEAD MASONRY	3/16"	N/A	90H027004
WOOD STUD/GYPSUM WALL	#9 X 2 1/4" PHILLIPS WAFER HEAD DRYWALL SCREW	N/A	N/A	90H421002
20 GA. STEEL STUD/GYPSUM WALL (OSHPD)	1/4-20 X 3" FLAT HEAD BOLT 1/4" TOGGLER WING 3M MOLDABLE FIRE PUTTY	1/2"	N/A	90H282002 90H062004 90M012000

HRS-6C HANDRAIL

LAYOUT VIEW

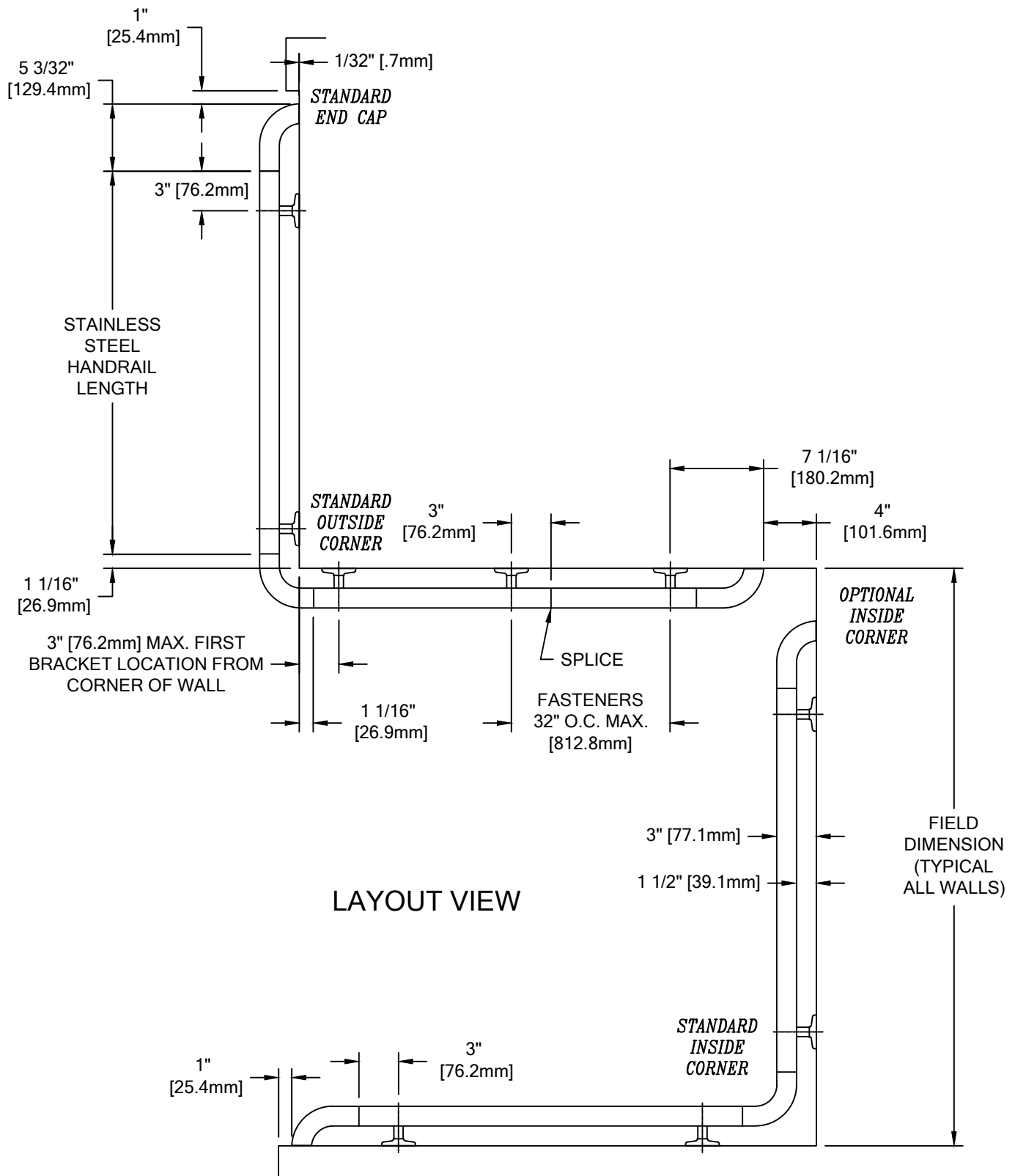

LAYOUT VIEW

**HRS-6C HANDRAIL**

TYPICAL ASSEMBLY

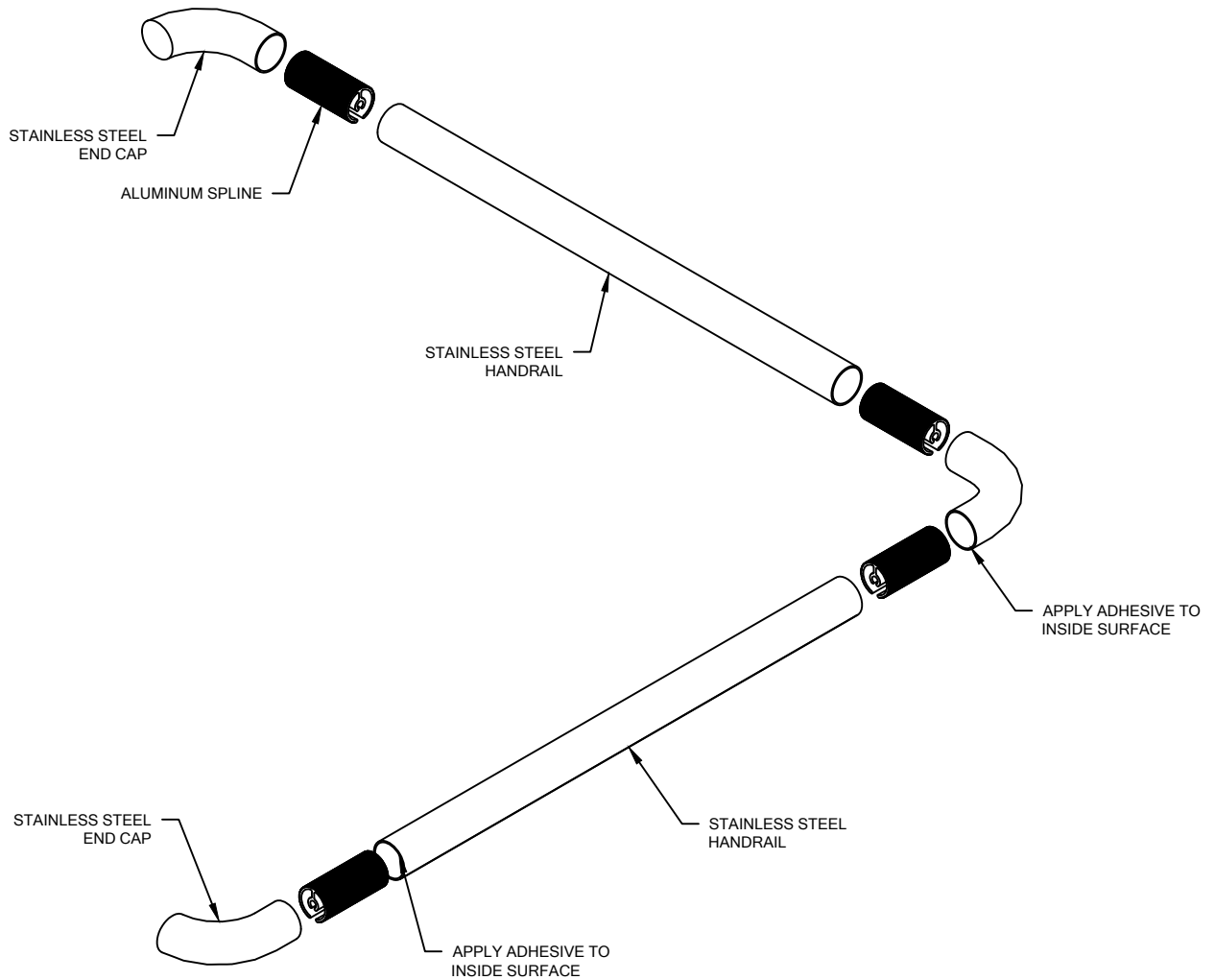

1. USING "LOCAL CODE" REQUIREMENTS, ESTABLISH HANDRAIL HEIGHT ABOVE FINISHED FLOOR. DEDUCT 3 9/16" [90.5mm] AND SNAP A CHALK LINE AT THAT HEIGHT. THIS MARKS THE LOCATION OF THE HOLE FOR THE MOUNTING BRACKET FASTENERS. REFER TO SECTIONAL VIEW.
2. DISTRIBUTE MATERIAL. MATCH THE NUMBER ON THE RAIL TO THE MARK NUMBER ON THE DRAWING. SOME LARGE RUNS REQUIRE MORE THAN ONE PIECE OF HANDRAIL. THESE ARE NOTED WITH A MARK NUMBER AND A LETTER, I.E., 2001A, 2001B.
3. ATTACH END CAPS AND/OR INSIDE/OUTSIDE CORNERS (A FLAT SURFACE IS REQUIRED):
  - TO PROTECT FINISHED SURFACES FROM ADHESIVE DURING ASSEMBLY APPLY MASKING TAPE TO END OF HANDRAIL'S SURFACE AND ALSO TO EXTERIOR SURFACE OF END CAP (OR INSIDE/OUTSIDE CORNER).
  - USING 100 GRIT SANDPAPER, SAND THE INTERIOR SURFACE OF THE HANDRAIL. CLEAN THE INTERIOR SURFACE OF HANDRAIL WITH ISOPROPYL (RUBBING) ALCOHOL.
  - DRY FIT THE ALUMINUM SPLINE BEFORE APPLYING ADHESIVE. THE ALUMINUM SPLINE SHOULD BE INSTALLED WITH 5/8" [15.8mm] OF THE ALUMINUM SPLINE PROTRUDING FROM THE END OF THE STAINLESS STEEL HANDRAIL.
  - ONCE TESTED, REMOVE AND APPLY 1/8" BEAD OF ADHESIVE TO SANDED, INTERIOR SURFACE (REFERENCE CAULKING GUN CONVERSION KIT FIGURES 3 & 4) AND PERMANENTLY ATTACH ALUMINUM SPLINE.
  - USING 100 GRIT SANDPAPER, SAND THE INTERIOR SURFACE OF THE END CAP (OR INSIDE/OUTSIDE CORNER). CLEAN THE INTERIOR SURFACE OF END CAP (OR INSIDE/OUTSIDE CORNER) WITH ISOPROPYL (RUBBING) ALCOHOL. APPLY 1/8" BEAD OF ADHESIVE TO SANDED, INTERIOR SURFACE.
  - THE ADHESIVE ONLY ALLOWS FOR 8 TO 12 MINUTES OF WORKING TIME. INSTALL END CAP (OR INSIDE/OUTSIDE CORNER) OVER ALUMINUM SPLINE. FOR A PROPER SEAM, STAINLESS STEEL END CAP (OR INSIDE/OUTSIDE CORNER) MUST BE TIGHTLY FITTED TO THE HANDRAIL. PARTS CAN BE HANDLED IN 1-1/2 HOURS AND WILL BE FULLY CURED AFTER 24 HOURS.
  - IF HANDRAIL SPLICE IS REQUIRED, INSTALL BEFORE SECOND END CAP.
  - INSTALL SECOND END CAP (OR INSIDE/OUTSIDE CORNER) AS PREVIOUSLY DESCRIBED. USING A FLAT SURFACE, ROTATE SECOND END CAP (OR INSIDE/OUTSIDE CORNER) UNTIL PARALLEL AND PROPERLY ORIENTED.

**HRS-6C HANDRAIL**

TYPICAL ASSEMBLY

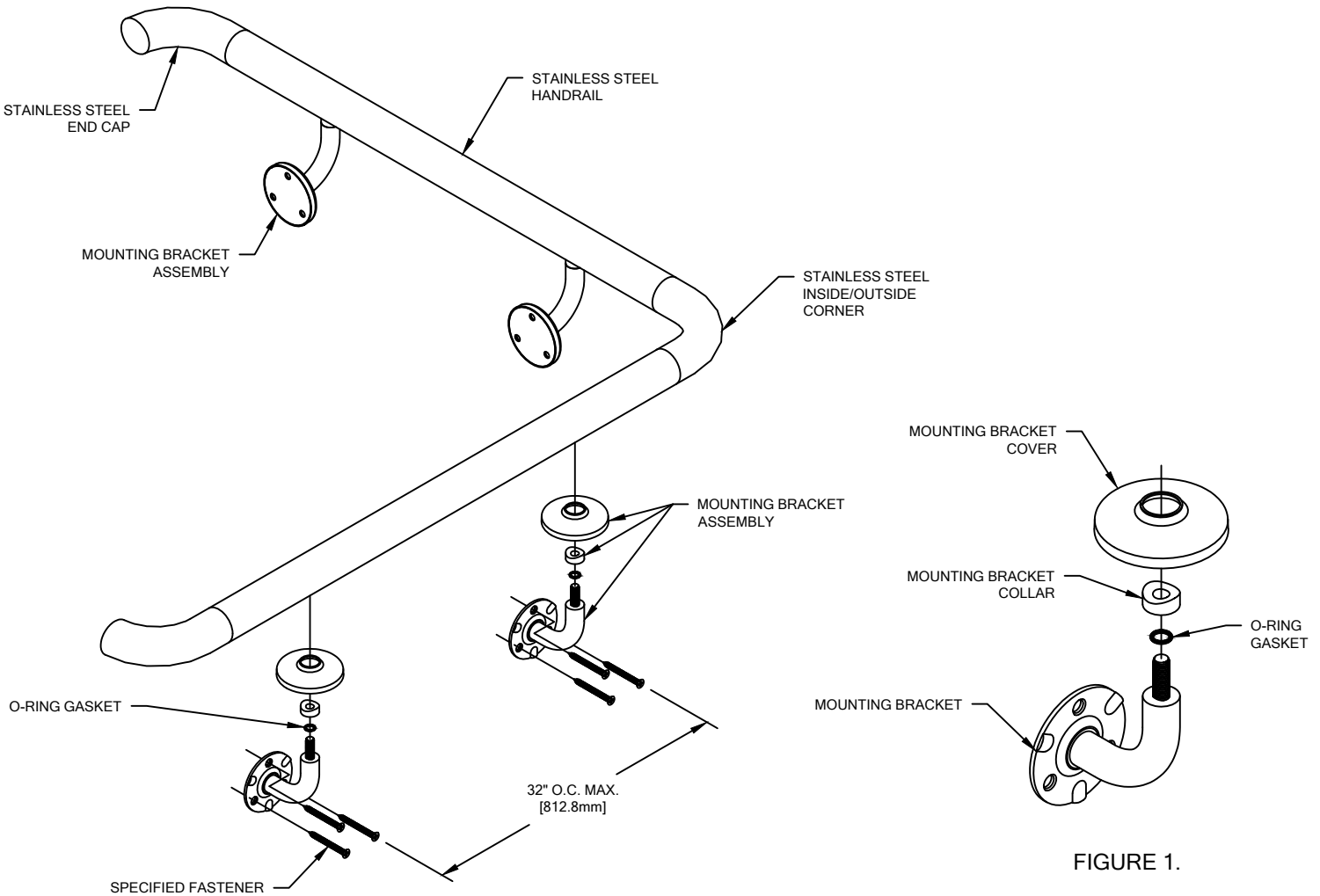

FIGURE 1.

4. ATTACH MOUNTING BRACKET ASSEMBLIES (A FLAT SURFACE IS REQUIRED):

- REMOVE PACKAGING FROM STAINLESS STEEL HANDRAIL AND STAINLESS STEEL END CAPS (OR INSIDE/OUTSIDE CORNERS).
- USING FLAT SURFACE ORIENT THE HANDRAIL (WITH END CAPS) UPSIDE DOWN.
- DRILL PILOT HOLES IN BOTTOM SURFACE OF STAINLESS STEEL HANDRAIL AS PER MOUNTING BRACKET DRILL JIG INSTRUCTIONS (SEE FIGURE 2). MOUNTING BRACKETS ARE TO BE LOCATED AT A MAXIMUM OF 32" [812.8mm] O.C. AND NO LESS THAN 3" [76.2mm] FROM END OF STAINLESS STEEL HANDRAIL. CAUTION: BE SURE THE HANDRAIL DOES NOT ROTATE WHEN DRILLING PILOT HOLE.
- BEFORE USING THE 21/64" BUSHING (TAP END OF MOUNTING BRACKET JIG) ON THE HANDRAIL'S FIRST PILOT HOLE, INSERT A 17/64" DRILL BIT THROUGH MOUNTING BRACKET DRILL JIG AND INTO PILOT HOLE. THIS STEP WILL HELP ENSURE HANDRAIL DOES NOT ROTATE WHEN DRILLING AND TAPPING FOR ADDITIONAL MOUNTING BRACKETS. A SECOND MOUNTING BRACKET DRILL JIG HAS BEEN PROVIDED TO DRILL AND TAP FOR ADDITIONAL MOUNTING BRACKETS.
- USING THE 21/64" BUSHING (TAP END OF MOUNTING BRACKET JIG), THREAD PILOT HOLE USING AN 8mm X 1.25mm TAP (PLUG CHAMFER TYPE RECOMMENDED).
- ATTACH MOUNTING BRACKETS. CAUTION: OVER TORQUEING MAY CAUSE DAMAGE TO THREADS.

5. USE ASSEMBLED HANDRAIL AS A TEMPLATE TO DRILL CLEARANCE HOLES IN WALL SURFACE FOR MOUNTING HARDWARE BY LINING UP UPPER EDGE OF MOUNTING BRACKET WITH CHALK LINE.

6. ATTACH ENTIRE ASSEMBLY TO THE WALL USING APPROPRIATE FASTENERS.

HRS-6C HANDRAIL

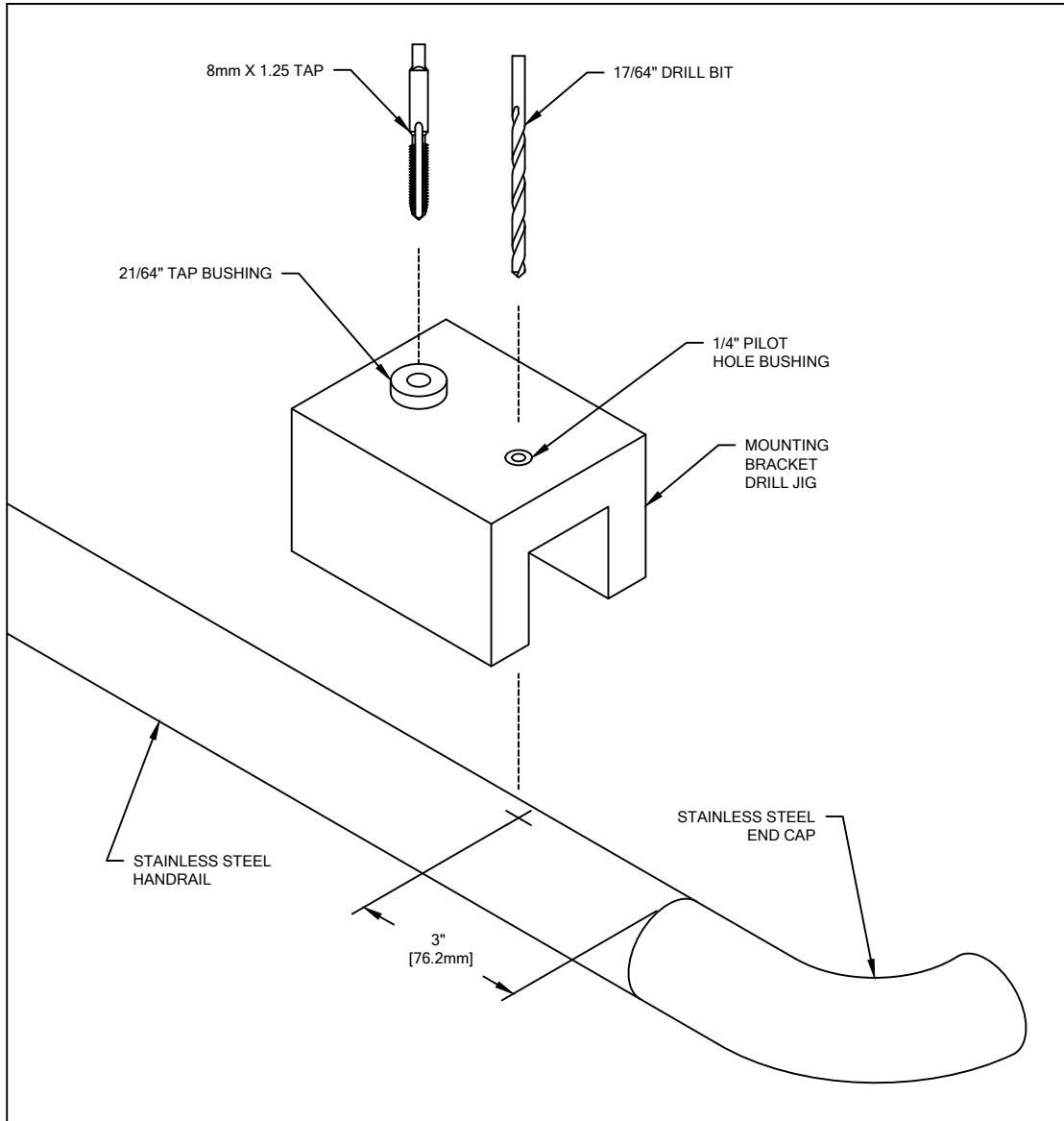

FIGURE 2.  
MOUNTING BRACKET DRILL JIG

MOUNTING BRACKET DRILL JIG INSTRUCTIONS. REFER TO FIGURE 2.

1. PLACE HANDRAIL ON A FLAT WORKING SURFACE AND ROTATE UNTIL BOTTOM OF HANDRAIL IS FACING UPWARD.
2. POSITION DRILL JIG OVER STAINLESS STEEL HANDRAIL. THE DRILL JIG'S FEET MUST SIT FLAT ON LEVEL WORKING SURFACE. LOCATE CENTER OF 17/64" PILOT DRILL HOLE OVER CORRESPONDING LOCATION FOR MOUNTING BRACKET ASSEMBLY.
3. DRILL A 17/64" PILOT HOLE (ONLY 1" DEEP) IN BOTTOM OF HANDRAIL.
4. POSITION TAP END OF MOUNTING BRACKET JIG OVER PREVIOUSLY DRILLED 17/64" PILOT HOLE. USE 21/64" DRILL BUSHING TO CORRECTLY THREAD PILOT HOLE WITH 8mm X 1.25 TAP (PLUG CHAMFER TYPE RECOMMENDED).

HRS-6C HANDRAIL

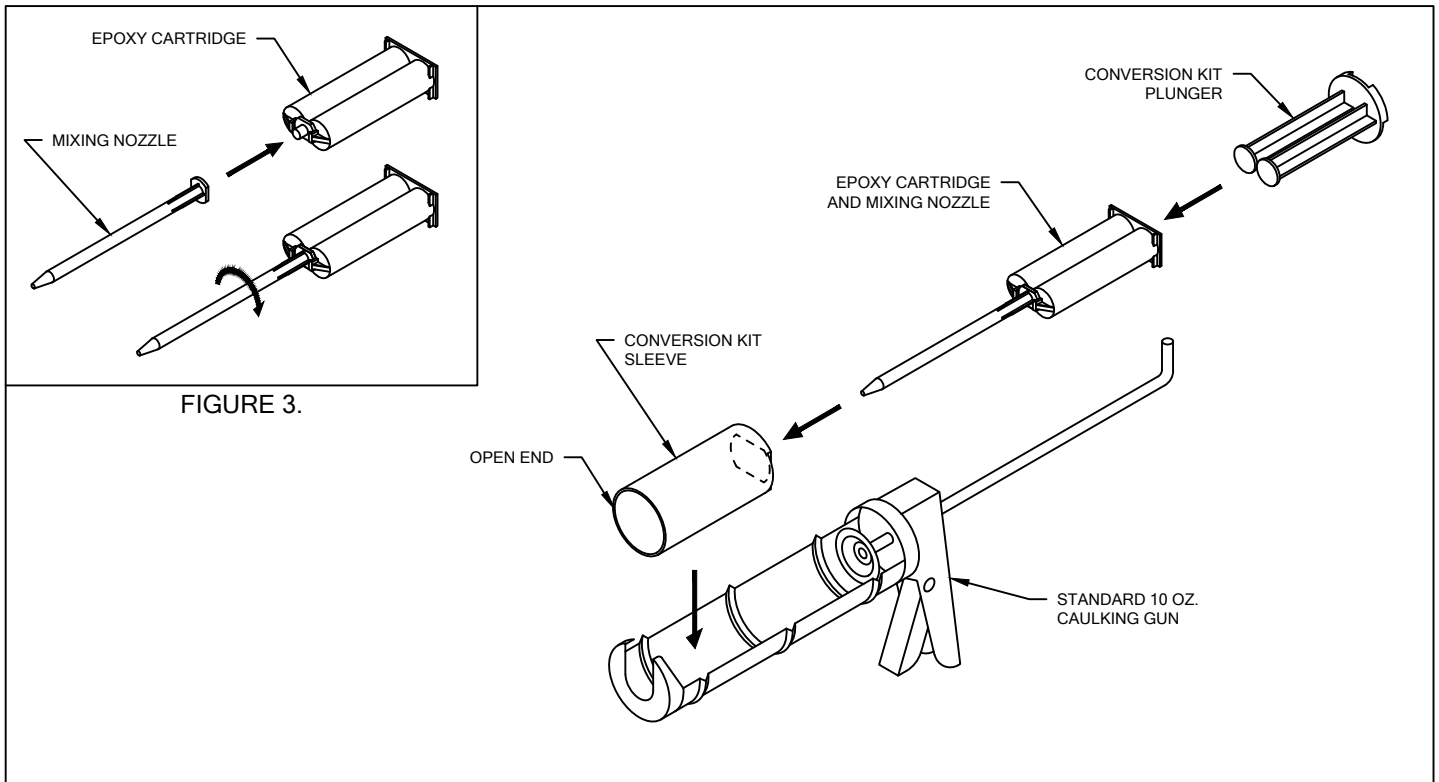

FIGURE 4.  
CAULKING GUN CONVERSION KIT

EPOXY CARTRIDGE AND MIXING NOZZLE. REFER TO FIGURE 3.

1. REMOVE CAP AND GASKET FROM THE END OF EPOXY CARTRIDGE BY TWISTING 90°.
2. INSTALL MIXING NOZZLE ON THE FRONT OF EPOXY CARTRIDGE AND LOCK IN PLACE BY TWISTING 90°.

CAULKING GUN CONVERSION KIT. REFER TO FIGURE 4.

1. INSERT EPOXY CARTRIDGE AND MIXING NOZZLE INTO OVAL OPENING OF SLEEVE. NOTE THE LOCATION OF OPEN END.
2. PLACE PLUNGER IN THE BACK END OF CARTRIDGE.
3. PLACE THE CONVERSION KIT, WITH MIXER NOZZLE AND EPOXY CARTRIDGE, IN A STANDARD 10 OZ CAULKING GUN AS SHOWN IN FIGURE 4. PLUNGER WILL ATTACH TO CIRCULAR PUSH PLATE ON CAULKING GUN.

02/04/19