

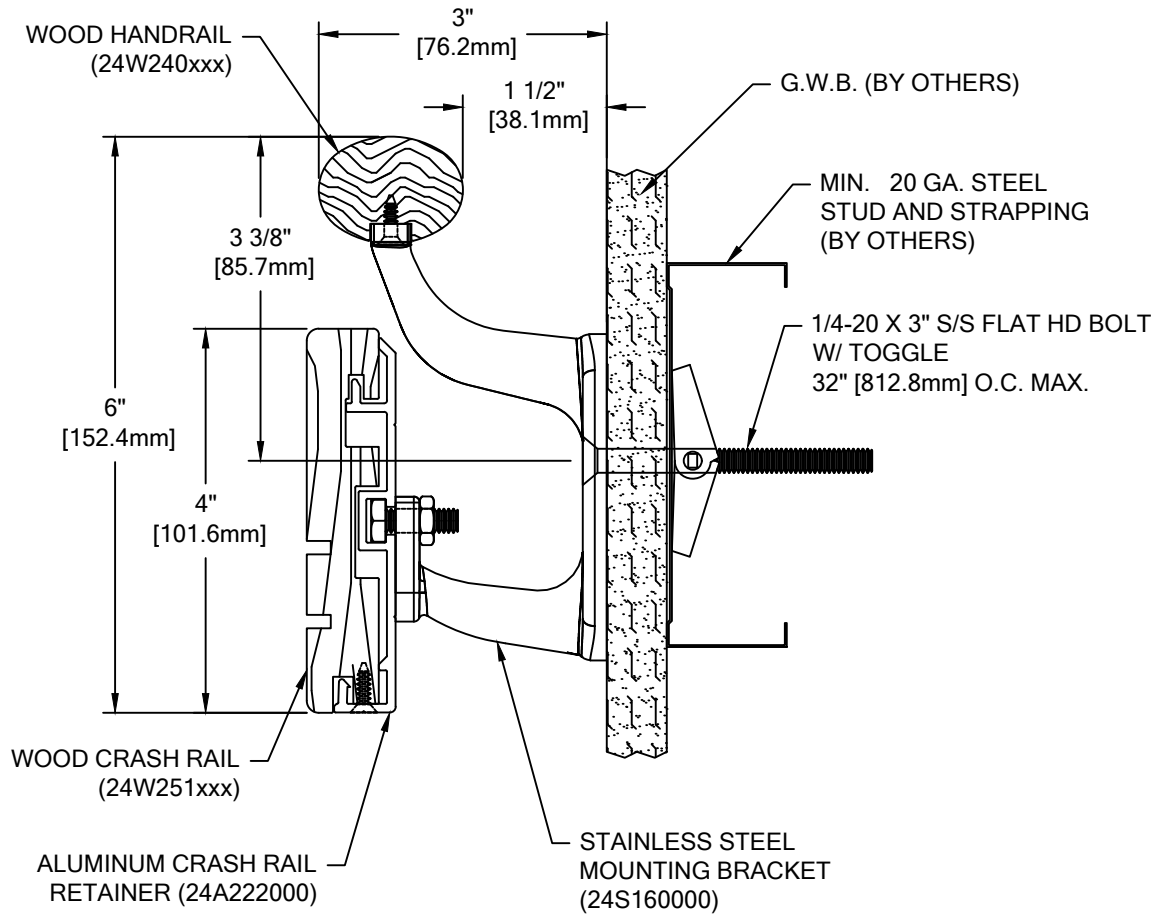

COLOR: _____
 TOP RAIL WOOD SPECIES: _____
 TOP RAIL WOOD FINISH: _____
 BOTTOM RAIL WOOD SPECIES: _____
 BOTTOM RAIL WOOD FINISH: _____
 *BRACKETS: _____
 COLOR TO BE SELECTED FROM ONE OF C/S STANDARD COLORS.
 *BRACKETS ARE AVAILABLE WITH AN OPTIONAL POWDER COAT FINISH.
 PLEASE ADVISE POWDER COAT FINISH IF REQUIRED.

| TOTAL L/F REQ'D | LEFT END CAPS | RIGHT END CAPS | O.S. REQ'D |
|-----------------|---------------|----------------|------------|
| | | | |
| | | | |
| | | | |



P-OWWG

| WALL CONDITION | SPECIFIED FASTENER | DRILL DIAMETERS | | C/S PART NUMBER |
|---------------------------------------|---|-----------------|----------|-------------------------------------|
| | | WALL | RETAINER | |
| STEEL STUD/GYPSUM WALL | 1/4-20 X 3" S/S FLAT HEAD BOLT WITH TOGGLE | 3/4" | N/A | 90H184002 |
| CONCRETE/CONCRETE BLOCK | 1/4" X 1 3/4" S/S FLAT HEAD MASONRY ANCHOR | 3/16" | N/A | 90H390000 |
| WOOD STUD/GYPSUM WALL | #14 X 3" S/S PHILLIPS FLAT HEAD WOOD SCREW | 7/32" | N/A | 90H538004 |
| 20 GA. STEEL STUD/GYPSUM WALL (OSHPD) | 1/4 - 20 X 3" S/S FLAT HEAD BOLT 1/4" TOGGLER WING 3M MOLDABLE FIRE PUTTY | 1/2" | N/A | 90H063002 90H062004 90M012000 |

| | | |
|--|------------------|------------------|
|  <p>Construction Specialties™ 6696 Route 405 Highway, Muncy PA 17756 (800) 233-8493 • Fax (570) 546-4692 • www.c-sgroup.com</p> | PROJECT: | REVISION: |
| | JOB NO.: | F&F: |
| | CUSTOMER: | |
| | REP: | DATE: |
| | DRAWN BY: | SHEET NO: |