

5/8" GRIDLINE WITH NO FRAME AND HIDDEN LOCK DOWNS

INSERT STYLE: N/A

INSERT COLOR: N/A

CATALOG NUMBER: G6

PART NUMBER:

NO.	REVISION	DATE	BY
NO.	F&F RELEASE	DATE	BY

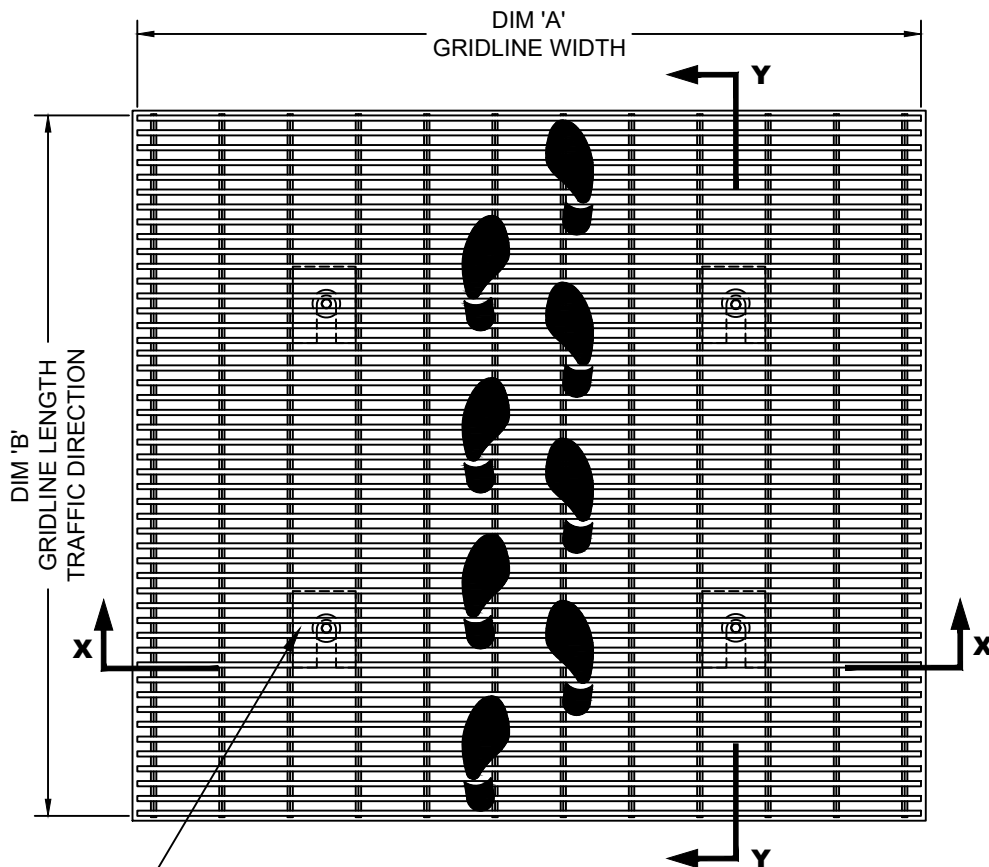

.090" X 3/4" X 15/16" SLOTTED HOLD-DOWN PLATE 1 AT EACH CORNER THEN SPACE 24" TO 30" O.C. ALL FACING THE SAME DIRECTION. (90F036001)

TYPICAL PLAN VIEW

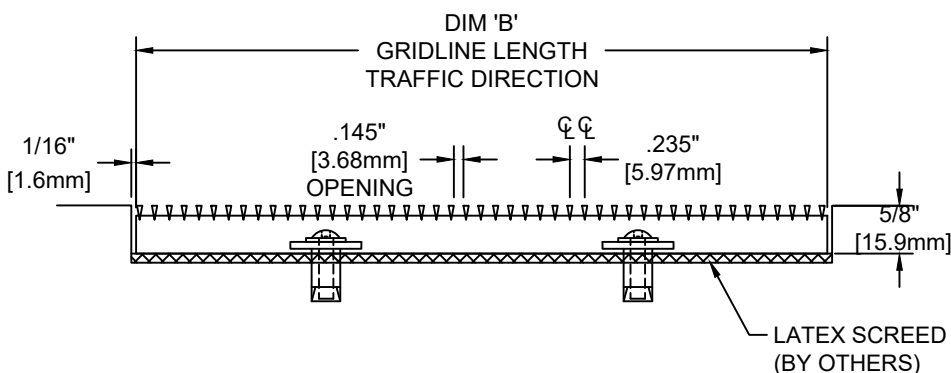

SECTION Y-Y

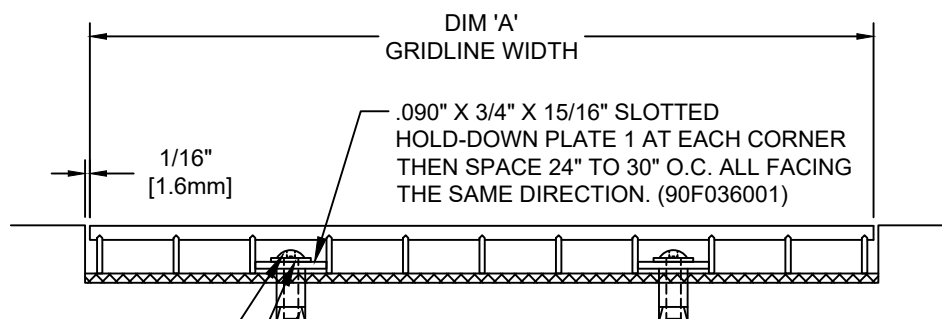

SECTION X-X

- #10-24 X 1" BUTTON HEAD CAP SCREW (90H690002)
- 10-24 FLAT WASHER (90H078003)
- Ø10-24 EXPANSION SHIELD (90H113004)

NOTES:

*MAX. SINGLE GRID SIZE NOT TO EXCEED 95-1/4" [2.419M] IN WIDTH (DIM 'A') AND 49-1/16" [1.246M] IN LENGTH (DIM 'B')
 *ALL SURFACE WIRES AND SUPPORT BARS ARE ELECTRONICALLY RESISTANCE WELDED TO ENSURE CORRECT WEIGHT BEARING PROPERTIES.

*GRIDS SHALL BE ABLE TO SUPPORT A 1000LB ROLLING LOAD.
 * SURFACE WIRE SPACING PROVIDES A 57.7% EFFECTIVE OPEN AREA FOR DIRT AND MOISTURE REMOVAL.
 *ADDITIONAL SPECIFICATIONS ARE CONTAINED IN THE LATEST C/S CATALOG OR AT C-SGROUP.COM AND ARE CONSIDERED PART OF THIS TRANSMITTAL.

CS Construction Specialties™
 8696 Route 405 Highway, Muncy PA 17756
 (800) 233-8493 • Fax (570) 546-4692 • www.c-sgroup.com

PLEASE VERIFY ALL	QTY	MARK #	LOCATION	MODEL	DIM 'A' WIDTH	DIM 'B' LENGTH	REMARKS

PROJECT:		
LOCATION:		
CONTRACTOR:		
AGENT:		SHT:
DRG. BY:	DATE:	JOB NO.: