





PEDIMAT WITH ALUMINUM TAPERED ANGLE FRAME AND DRAIN				NO.	REVISION	DATE	BY
INSERT STYLE:	INSERT COLOR:	CATALOG NUMBER: M1	PART NUMBER:	NO.	F&F RELEASE	DATE	BY

-   
**EXTERIOR CARPET**  
 M1EC  
 19C005XXX
-   
**HEAVY-DUTY CARPET**  
 M1HC  
 19C010XXX
-   
**CUSTOM CARPET**  
 M1CC  
 19C019XXX
-   
**VINYL**  
 M1V  
 19V002XXX

**PEDIMAT INSERT STYLES**

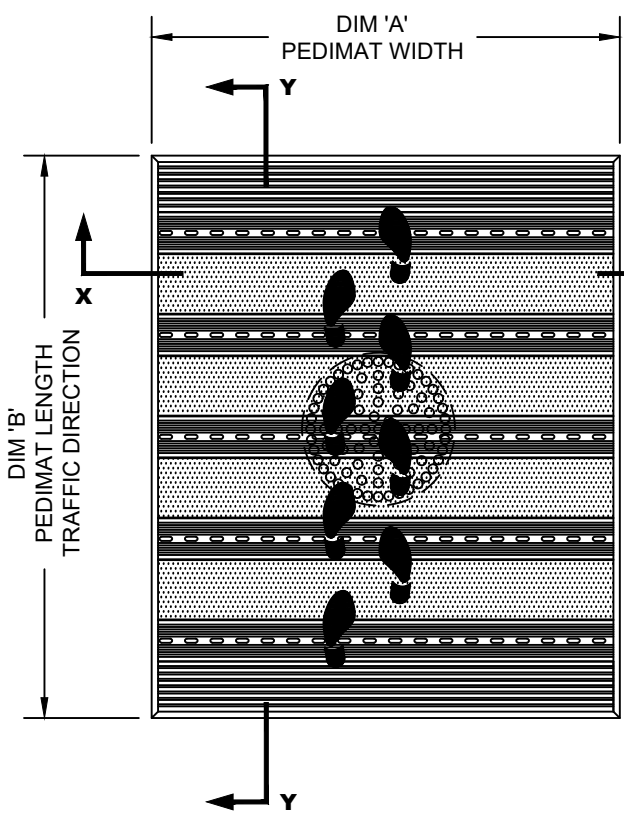

**TYPICAL PLAN VIEW**

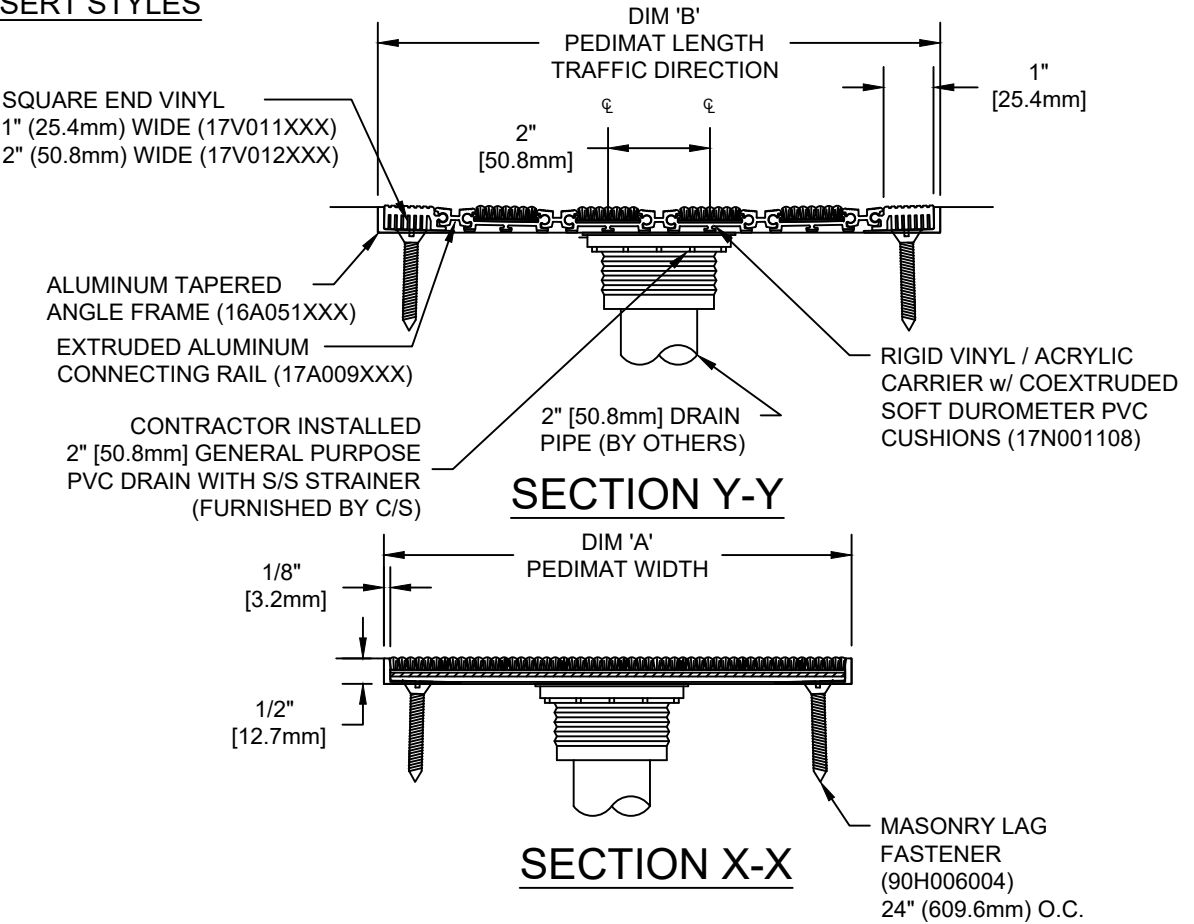

**NOTES:**

- \*ALL SURFACES IN CONTACT WITH MASONRY ARE TO RECEIVE A COAT OF ZINC CHROMATE PRIMER
- \*PLEASE VERIFY TRAFFIC DIRECTION
- \*PEDIMAT SHALL BE ABLE TO SUPPORT A 350 LB. ROLLING LOAD. LARGER LOADING MAY BE ACCOMODATED. CONTACT C/S SALES WITH SPECIFIC LOADING REQUIREMENTS.

- \*MAX. SINGLE GRID SIZE NOT TO EXCEED 12'-0" (3.66M) IN WIDTH (DIM "A") OR 100 SQUARE FEET
- \*ADDITIONAL SPECIFICATIONS ARE CONTAINED IN THE LATEST C/S CATALOG OR AT C-SGROUP.COM AND ARE CONSIDERED PART OF THIS TRANSMITTAL.



**Construction Specialties™**  
 8696 Route 405 Highway, Muncy PA 17756  
 (800) 233-8493 • Fax (570) 546-4692 • www.c-sgroup.com

PLEASE VERIFY ALL	QTY	MARK #	LOCATION	MODEL	DIM 'A' WIDTH	DIM 'B' LENGTH	FINISH	NOTES

PROJECT:		
LOCATION:		
CONTRACTOR:		
AGENT:		SHT:
DRG. BY:	DATE:	JOB NO.: