

RAIL: STAINLESS STEEL RAIL 10'-1" LONG PART# 24S153000	BRACKETS: ALUMINUM HEAVY DUTY "H" BRACKET PART #: 24F195003 NO. BRACKETS REQUIRED:	BRACKETS: EXTRUSION PART #: 24A273000 NO. BRACKETS REQUIRED:	WALL MOUNT HARDWARE: 1/4-20 x 3" HEX HEAD BOLT (90H281004) 1/4-20 x 2" TOGGLE (90H019004) 1/4" LOCK WASHER (90H009003)
QTY:	QTY:	QTY:	QTY:

NOTES:

1. THIS MODEL IS FABRICATED CUT-TO-SIZE, THEREFORE FIELD VERIFIED DIMENSIONS ARE REQUIRED.
2. ALL RAIL TO BE SUPPLIED PREFABRICATED TO REQUIRED LENGTH. ALL CORNERS AND END CAPS TO BE FACTORY FORMED TO SUIT FIELD DIMENSIONS.
3. ALL UNITS TO BE SUPPLIED WITH WELDED STUDS FOR ATTACHMENT. HOLE SPACING TO BE DETERMINED BY UNIT LENGTH, SPACING NOT TO EXCEED 32" ON CENTER.
4. ALL MOUNTING HARDWARE TO BE SUPPLIED FOR FIELD ASSEMBLY AND INSTALLATION.

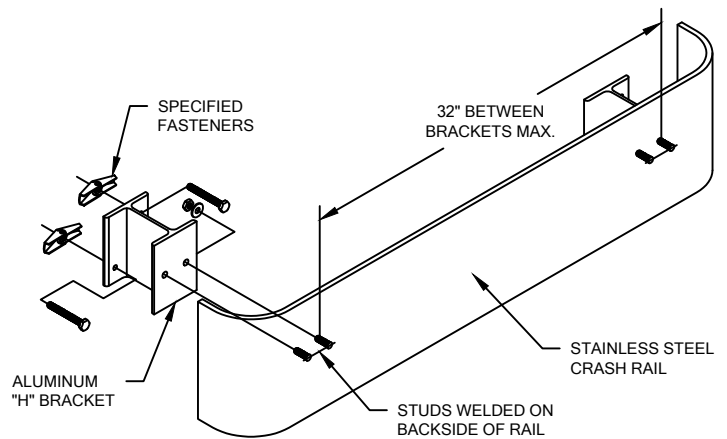
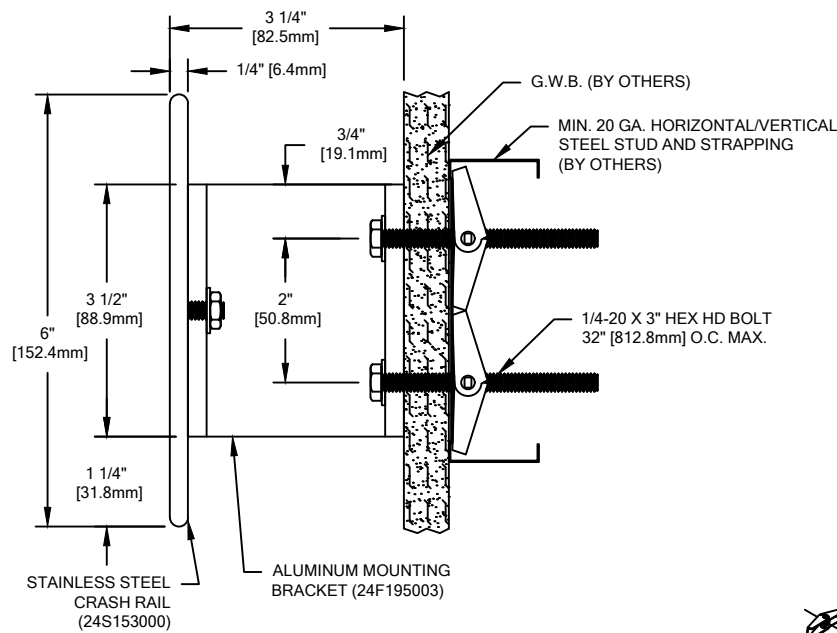

ECR-60S

NON-EXPOSED FASTENERS

TYPICAL ASSEMBLY

WALL CONDITION	SPECIFIED FASTENER	DRILL DIAMETERS		CS PART NUMBER
		WALL	RETAINER	
STEEL STUD/GYPSUM WALL	1/4-20 X 3" HEX HEAD BOLT 1/4-20 X 2" TOGLER 1/4" LOCK WASHER	3/4"	N/A	90H281004 90H019004 90H009003
CONCRETE/CONC. BLOCK	1/4-20 X 1 1/2" HEX HEAD BOLT 1/4" LOCK WASHER 1/4-20 X 1 1/4" 4-WAY LEAD SHIELD	1/2"	N/A	90H863002 90H009003 90H020004
WOOD STUD/GYPSUM WALL	1/4" X 3" HEX HEAD LAG SCREW 1/4" LOCK WASHER	3/16"	N/A	90H967002 90H009003

 <p>Hughesville, PA 800.233.8493 570.546.5941 Mississauga, ON 888.895.8955 905.274.3611 www.c-sgroup.com</p> <p>© Copyright 2017 Construction Specialties, Inc.</p>	PROJECT:	REVISION:
	JOB NO.:	F&F:
	CUSTOMER:	
	REP:	DATE:
	DRAWN BY:	SHEET NO: