

ATTENTION

Please read these instructions thoroughly prior to beginning the **VA CORNER GUARD** installation!

This instruction sheet is intended to provide a specific guide to follow for the installation of the **VA CORNER GUARDS**. Contained within is the technical information and installation techniques required to complete an efficient, neat, and long-lasting installation.

See "**Corner Guard- Supplemental Information**" sheet for additional notes and other helpful installation tips.

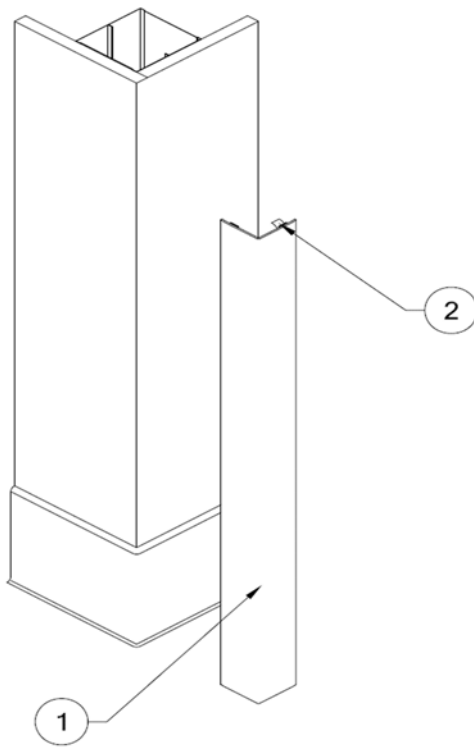
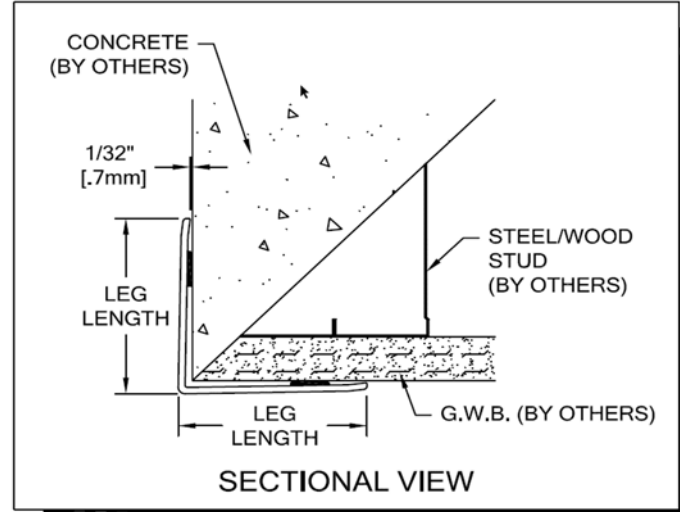

Parts List

1. VA Corner Guard
 - a. VA-034 = 20N014XXX
 - b. VA-200 = 23N003XXX
 - c. VA-250 = 23N018XXX
 - d. VA-200M = 23N003XXX ODD ANGLE
 - e. VA-250M = 23N018XXX ODD ANGLE
2. Factory applied double stick foam tape

INSTALLATION INSTRUCTIONS

1. Locate and install CS Corner guards in accordance with architectural drawings and specifications. When required, CS shop drawings should be used in conjunction with these documents.
2. Lay out the work to be completed, including component parts at each location to receive corner guards as indicated by the CS shop drawings. Spot check the material for any damage incurred during shipping and/or handling at the jobsite.
3. The installation surfaces must be thoroughly cleaned, free of dirt, Grease, Wax, and loose paint.
4. Remove the protective covering from the foam tape located on the rear of each leg of the corner guard.
5. Install the corner guard by aligning the bottom of the corner guard with the top of the cove base or finish floor and moving the guards into position along the apex of the wall surface and corner guard.
6. Apply pressure to the surface of the corner guard by rubbing each leg with a clean soft cloth to set the adhesive.
7. Space between the corner guard and the wall is 1/32", but may vary due to corner bead and wall finishing.

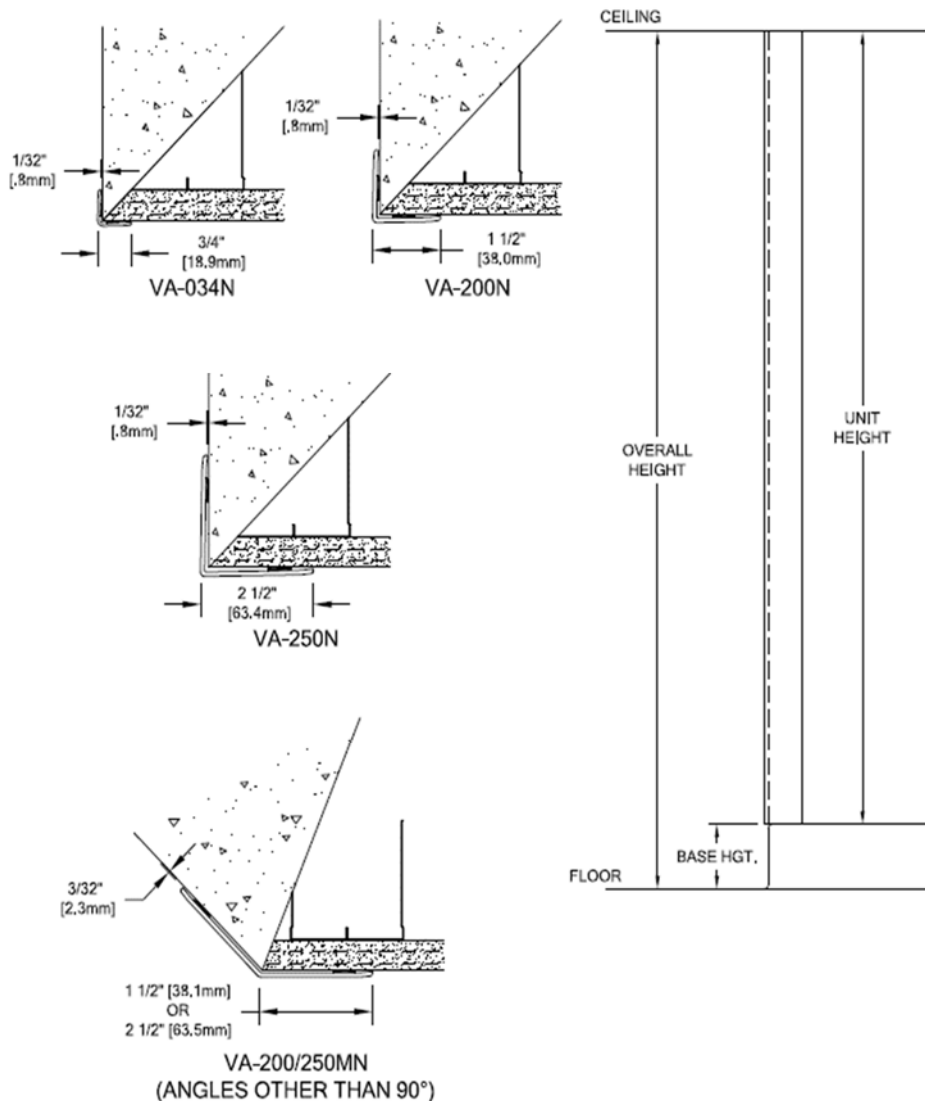

Hughesville, PA | 800.233.8493 | 570.546.5941
 Mississauga, ON | 888.895.8955 | 905.274.3611

www.c-sgroup.com
IWPTechSupport@c-sgroup.com