

Model DC-9614
9" (228.6 mm) Storm Resistant Dade County Hurricane Louver

NOA: 24-0226.05
 Florida Product Approval: FL-21146
 Maximum wind-load: 160 PSF

Material:

Material:	6063-T6 Alloy
Nominal Thickness (heads, sills, jamps, & mullions):	0.080" (2.03 mm)
Nominal Blade Thickness:	0.068" (1.73 mm) & 0.060" (1.52 mm)
Furnished With:	Birdscreen: ½" intercrimp aluminum mesh, 0.063" diameter wire removeable aluminum bird screen in an aluminum frame
Additional Options (at additional cost):	Insect screen (in lieu of bird screen), Continuous clip angles for attachment Sheet blank off, Insulated blank off Sill pans, Flange frames Integrated glazing frames

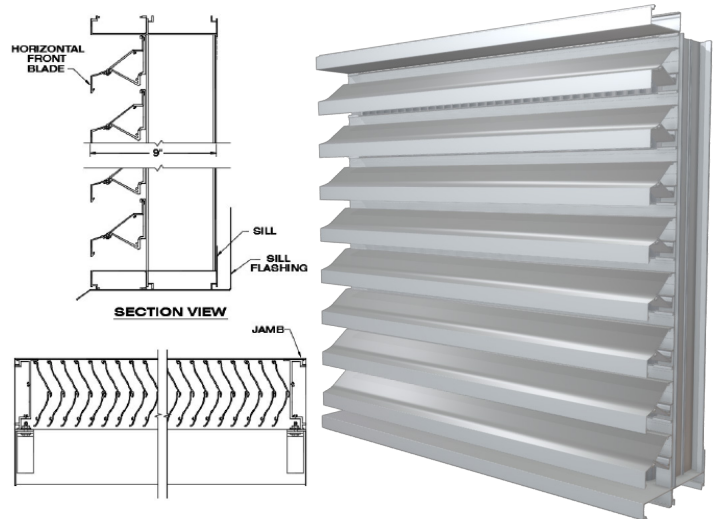

Discharge Coefficient
 Intake Cd = 0.29 (Class 3)
 AMCA certifies the coefficient class only

Test Summary:

For a 4 Foot by 4 Foot Unit.

Tested with mill finish and no screen

- Free area = 9.46 ft² (0.88 m²)
- Percent free area = 59.1%
- Intake pressure drop at 1,000 FPM free area velocity = 0.34 in. H₂O (84.4 Pa)
- To maintain a CLASS A (99%) effectiveness rating* with:
 - a 50 mph wind speed and rainfall rate of 8 in/hr
 - Max. intake core velocity 5.0 m/s (977 FPM)
 - Max. intake free area velocity 7.57 m/s (1,490 FPM)

*Tested with 1m² core area, mill finish and no screen**

Dade County Protocols:

- TAS-201: Large and small missile impact
- TAS-202: Criteria for testing impact and not impact resistant building envelope components using static uniform air pressure
- TAS-203: Criteria for testing products subject to cyclic wind pressure

Construction Specialties Inc. certifies that the louver model DC-9614 shown herein is licensed to bear the AMCA Seal.

The ratings shown are based on tests and procedures performed in accordance with AMCA Publication 511 and comply with the requirements of the AMCA Certified ratings Program. The AMCA Certified Ratings Seal applies to wind driven rain and air performance ratings.



Application and Design

DC-9614 is tested in accordance with AMCA 500-L Air Performance and Wind Driven Rain. DC-9614 is tested in accordance with AMCA 550 Test Method for High Velocity Wind Driven Rain Resistant Louvers. DC-9614 is tested in accordance with AMCA 540 Test Method for Louvers Impacted by Wind Borne Debris (Basic Protection, Missile Level D and Enhanced Protection, Missile Level E). Minimum louver section size to be 16" x 16".

Construction Specialties Inc. certifies that the louver model DC-9614 shown herein is approved to bear the AMCA Listing Label.

The ratings shown are based on tests and procedures performed in accordance with AMCA Publications and comply with the requirements of the AMCA Listing Label Program. The AMCA Listing Label applies to High Velocity Wind Driven Rain Resistant Louvers. The AMCA Listing Label applies to Wind Borne Debris Impact Louvers.

Model DC-9614
9" (228.6 mm) Storm Resistant Dade County Hurricane Louver

Wind Driven Rain Performance: Tested with 1m² core area, mill finish and no screen

50 mph (22.3 m/s) & 8" (203 mm) rain per hour

Core Velocity Through Cal. Plate (m/s):	0.0	0.5	1.0	1.5	2.0	2.5	3.0	3.5	4.0	4.5	5.0
Core Velocity Through Louver (ft/min):	0	98	197	295	394	492	591	689	787	854	977
Free Area Velocity (ft/min):	0	150	300	450	600	750	900	1050	1201	1302	1490
Rating Effectiveness:	A	A	A	A	A	A	A	A	A	A	A
Effectiveness Ratio (%):										100.0	99.7
Effectiveness Rating:	A = 1 to 0.99			B = 0.989 to 0.95			C = 0.949 to 0.80			D = Below 0.80	

Free Area Table (Free area in sq. feet and sq. meters)

For additional sizes, please visit:

<https://www.c-sgroup.com/architectural-louvers/louvers-airflow-tool>

Width in Inches and Meters

	16	18	24	30	36	42	48	54	60
	0.41	0.46	0.61	0.76	0.91	1.07	1.22	1.37	1.52
16	0.68	0.79	1.13	1.47	1.80	2.14	2.48	2.82	3.16
0.41	0.06	0.07	0.10	0.14	0.17	0.20	0.23	0.26	0.29
18	0.80	0.93	1.33	1.72	2.12	2.52	2.92	3.31	3.71
0.46	0.07	0.09	0.12	0.16	0.20	0.23	0.27	0.31	0.34
24	1.15	1.34	1.92	2.50	3.07	3.65	4.22	4.80	5.38
0.61	0.11	0.12	0.18	0.23	0.29	0.34	0.39	0.45	0.50
30	1.51	1.76	2.51	3.27	4.02	4.78	5.53	6.29	7.04
0.76	0.14	0.16	0.23	0.30	0.37	0.44	0.51	0.58	0.65
36	1.87	2.18	3.11	4.04	4.97	5.91	6.84	7.77	8.71
0.91	0.17	0.20	0.29	0.38	0.46	0.55	0.64	0.72	0.81
42	2.22	2.59	3.70	4.81	5.93	7.04	8.15	9.26	10.37
1.07	0.21	0.24	0.34	0.45	0.55	0.65	0.76	0.86	0.96
48	2.58	3.01	4.30	5.59	6.88	8.17	9.46	10.75	12.04
1.22	0.24	0.28	0.40	0.52	0.64	0.76	0.88	1.00	1.12
54	2.94	3.42	4.89	6.36	7.83	9.30	10.76	12.23	13.70
1.37	0.27	0.32	0.45	0.59	0.73	0.86	1.00	1.14	1.27
60	3.29	3.84	5.49	7.13	8.78	10.43	12.07	13.72	15.36
1.52	0.31	0.36	0.51	0.66	0.82	0.97	1.12	1.27	1.43
66	3.65	4.26	6.08	7.91	9.73	11.56	13.38	15.21	17.03
1.68	0.34	0.40	0.57	0.73	0.90	1.07	1.24	1.41	1.58
72	3.83	4.47	6.38	8.29	10.21	12.12	14.03	15.95	17.86
1.83	0.36	0.41	0.59	0.77	0.95	1.13	1.30	1.48	1.66
78	4.18	4.88	6.97	9.07	11.16	13.25	15.34	17.43	19.53
1.98	0.39	0.45	0.65	0.84	1.04	1.23	1.43	1.62	1.81
84	4.54	5.30	7.57	9.84	12.11	14.38	16.65	18.92	21.19
2.13	0.42	0.49	0.70	0.91	1.13	1.34	1.55	1.76	1.97
90	4.90	5.71	8.16	10.61	13.06	15.51	17.96	20.41	22.86
2.29	0.46	0.53	0.76	0.99	1.21	1.44	1.67	1.90	2.12
96	5.25	6.13	8.76	11.38	14.01	16.64	19.27	21.89	24.52
2.44	0.49	0.57	0.81	1.06	1.30	1.55	1.79	2.03	2.28
102	5.61	6.55	9.35	12.16	14.96	17.77	20.57	23.38	26.19
2.59	0.52	0.61	0.87	1.13	1.39	1.65	1.91	2.17	2.43
108	5.97	6.96	9.95	12.93	15.91	18.90	21.88	24.87	27.85
2.74	0.55	0.65	0.92	1.20	1.48	1.76	2.03	2.31	2.59
114	6.32	7.38	10.54	13.70	16.87	20.03	23.19	26.35	29.52
2.90	0.59	0.69	0.98	1.27	1.57	1.86	2.15	2.45	2.74
120	6.68	7.79	11.14	14.48	17.82	21.16	24.50	27.84	31.18
3.05	0.62	0.72	1.03	1.34	1.66	1.97	2.28	2.59	2.90

Upper Numerals English Units/Lower Numerals Metric Units

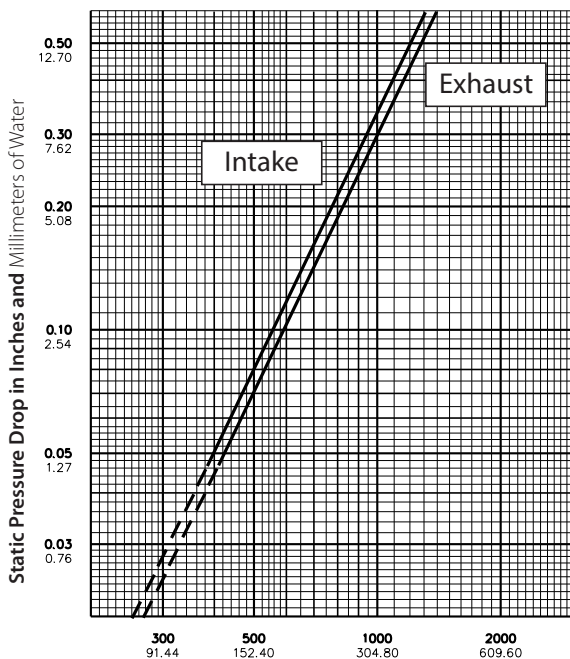

Air Velocity in Feet and Meters per Minute Through Free Area

Data corrected to standard air density.
 48" x 48" louver tested to figure 5.5.